

DIGGERKING

King T15 SM



OPERATOR'S MANUAL

DIGGERKING.COM.AU

CONTENTS

I. MACHINE NUMBER	1
II. APPLICATION AREA	1
III. COMPONENTS OF MACHINE	2
IV. OPERATING ORIENTATION	2
V. SAFETY OPERATION	2
VI. OPERATION GUIDE	5
VII. CONTROL SYSTEM	6
VIII. PREPARATION BEFORE WORK	12
IX. ATTACHMENT CONNECTION	16
X. DRIVE	18
XI. MACHINE STORAGE	19
XII. SAFETY SERVICE & MAINTENANCE	20
XIII. MAIN SPECIFICATIONS	33
XIV. SUPPORT	34

I . Machine Number

The machine number is in the below area, indicated by arrow.

Each machine has its own unique number; please fill up its info. to below form.

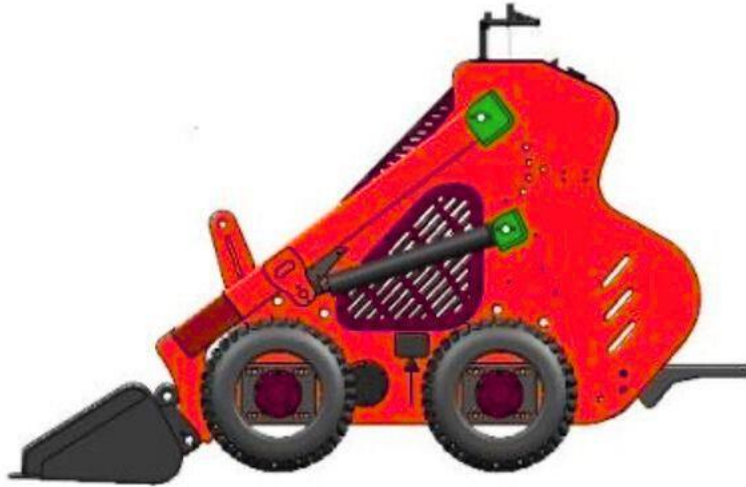

Model:	
Serial No.:	
Engine No.:	
Date of Production:	
Manufacturer:	
Address:	
Distributor:	

II . Application Area

DIGGER KING T15 is a wheeled mini skid steer loader designed for compact construction work. With quick coupling, it can be easily connected to various attachments. In normal condition, from minor construction work, ground-care, home renovation, landscaping, farming to small scale carrying works; it is proficient in any compact roadway or low space working. Any working in extreme area if necessary, please contact with HT or your local dealer, otherwise it will be conflicted to its application.

The DIGGER KING T15 should be operated, serviced and repaired only by trained operator who is familiar with its particular characteristics and acquainted with safety operation.

III. Components of Machine

- A. Mount plate
- B. Lift arm
- C. Tire
- D. Upper cover
- E. Side guard
- F. Engine
- G. Operator station
- H. Machine body
- I. Foot pedal/platform



IV. Operating Orientation

- A. Front of the machine
- B. Right of the machine
- C. Rear of the machine
- D. Left of the machine

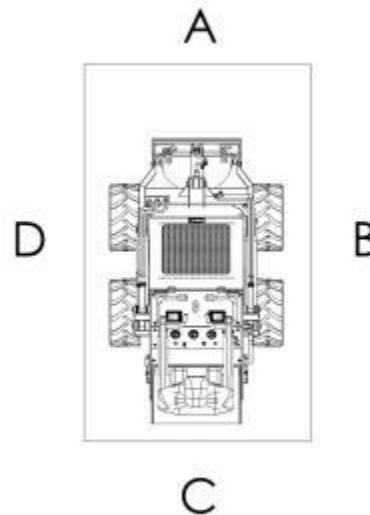

V. Safety Operation



Warning

Follow safety operation instructions before using and maintaining the machine. Read the manual and marks the on machine.

Follow the marks on manual and instruction to repair, adjust and maintain; and check if proper afterwards. It may cause death or injury if disobey.

Safety is the responsibility of operator.

Most accidents involving machine operation and maintenance can be avoided by following basic safety rules and precautions. Read and understand all the safety messages in this manual, safety operation, and safety decals on the machine before you operate or maintain the machine.



This symbol indicates caution , pay attention to your safety before operating loader skidding.

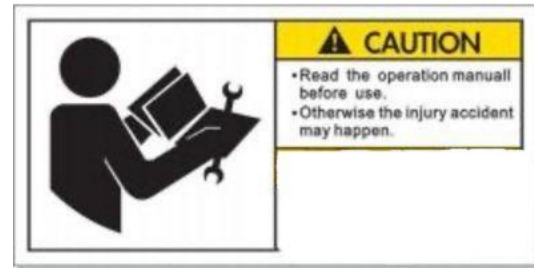
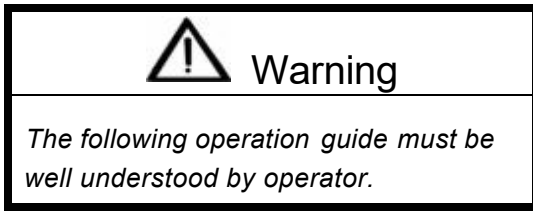

* Every guide and rule of operation and maintenance shall be understood and obeyed.



* When operating the machine, make sure to refill hydraulic oil and fuel in a proper way, otherwise it may cause danger or critical injury.

* Read this manual completely, and make sure you understand the controls, maintenance and refilling of fuel and oil.



This symbol indicates you to be careful; otherwise it may cause death to operator or bystander. The decal is labeled on the machine.



Safety decals on the machine and warning on the manual are indicated especially for you to realize the danger to avoid accidents.

Before delivering to the user, each loader was tested and examined thoroughly. You should operate carefully in the first 100 hours to keep all parts in good condition. Roughly operation will shortened the useful life or reduce the efficiency. For new Equipment, you should pay attention to the following:



Running the machine 5 minutes in idle after started.



Avoid operate the loader with full speed.



Avoid rapid start, rapid accelerate, unnecessary urgent stop or turning.



Clean the dust and scraping when you change the filter element.



Please check all potential dangerous if working in a poor environment.



Please check the working time of the hour meter.



Danger,



Warning,



Note,

these symbols are closely related to the safety of machine and operator.



Warning

Warning on the machine and manual is for your safety. May cause death or injury if disobey.



Danger

Danger indicates hazardous situation beside operator or machine which, if not avoided, will result in death or serious injury.



Note

Note indicates to follow the steps to avoid damage of machine.

Safety Warning Labels

Indicating:

“Caution”

“Warning”

“Involving your safety”

Safety labels point out important safety information of the machine; be alert to the possibility of injury or death when you see them, and obey safety instructions.

VI. Operation Guide

To new loaders

Loaders need running in for 100 hours, which will exert fully their capability and extend their useful lift. New loader should be used performing these three steps, avoid excessively use in the first 100 hours.

Hours	Load
Within 10hours	About 60%
Within 100hours	About 80%
After 100hours	100%





Use it carefully within the first 100 hours.

Preparation before Starting the Loader

Read this manual before using the machine.

Daily Check:

Make sure the engine working well, check the following items everyday:

-  Engine cooling system
-  Tire and tire pressure
-  Any loosen or damaged parts
-  Safety marks
-  Meter panel

- Check level of engine oil, hydraulic oil, fuel and see if any leakage.
- Check the lubricating oil regularly and replenish.
- Check meter and lights when running.
- Check if machine working well when running.
- Add oil to lubricating points everyday.
- Fasten bolts

Safety Drive

CAUTION: Try to keep low speed working in order for max stability.



Warning

Using machine excessively will make the machine be worsening and reduce its life.



Warning

Operate the machine without read operator's manual or training will result in damage of the machine or person injury.



Warning

*To avoid injury:
When operating the machine:
Keep your feet always on the pedal*

Load center changes when lift and down, do not turn rapidly or moving on slope when lifting.

Keep it on level ground when operating and turning.

Put down lift arm entirely when moving, and lift bucket to proper height, to avoid obstacles.

 Danger
<i>When bucket arm on high lever, high speed with rapid moving or turning of the machine may cause tipping or injury; Operating on low speed are required.</i>

VII、 Control System

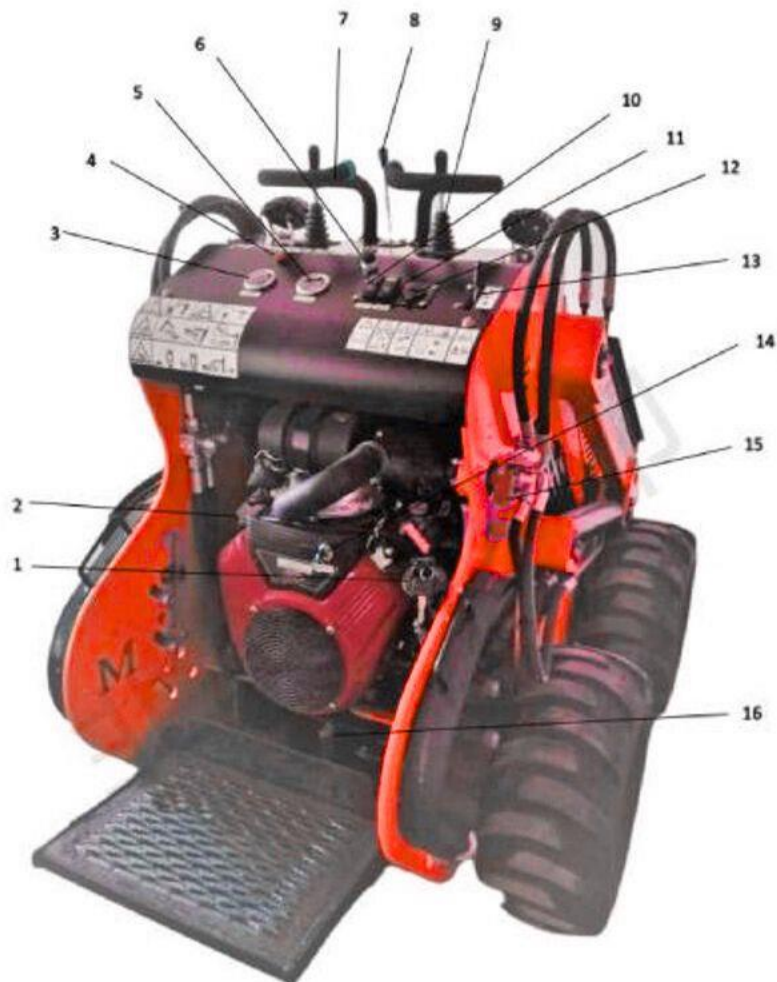

- | | | |
|----------------------|-------------------------|---------------------|
| 1. Engine Throttle | 2. Engine Choke | 3. Ammeter |
| 4. Alarm Light | 5. Hour Meter | 6. Horn Button |
| 7. Armrest | 8. Attachment Handle | 9. Operation Handle |
| 10. Head Light | 11. Oil Cooler Button | 12. USB Interface |
| 13. Hand Throttle | 14. Engine Start Switch | 15. Power Switch |
| 16. Fuel Level Gauge | | |

1. Engine Throttle

Fit it with fuel please.



2. Engine Choke

If you can not start the engine in the cold condition, pull the choke, switch as above picture, then press the start button to start the engine press down the switch to close the choke after starting.



3. Ammeter

It indicates amount of the battery, please recharge it when too low.



4. Alarm Light



When the ignition switch rotates clockwise in the on position, the power indicator lights up, the engine works, and then goes off. If it lights up at work, it means the oil pressure is insufficient and the fault occurs

5. Hour Meter

It is used to record the engine working time when start switch on.



6. Horn Button

Press the horn button to turn on the horn, release button to stop.



7/8/9. Armrest, Attachment Handle and Operation Handle

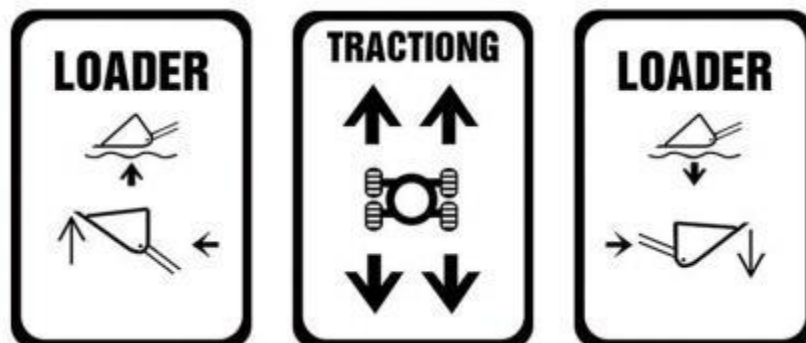

Forward: Move the handle forward, the right side tires will move forward, the machine will turn left.

Backward: Move the handle backward, the right side tires will move backward, the machine will turn right.

Leftward: Moving the handle toward the right side of the machine will lower the lift arm.

Rightward: Moving the handle toward the left side of the machine will raise the lift arm.

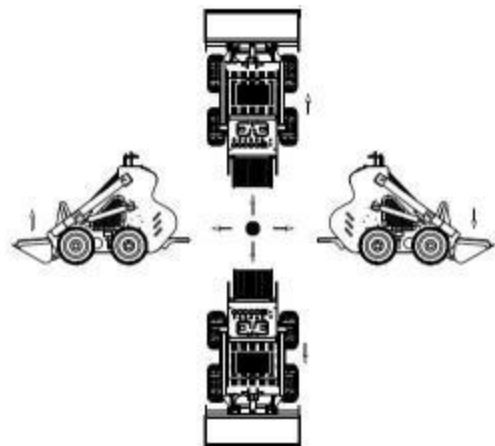

Attachment Handle

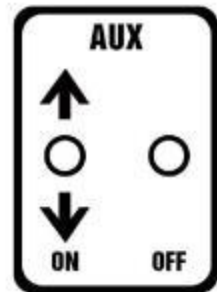

↑ **Forward:** Push the handle forward, the attachment will turn clockwise or the attachment cylinder extend.

↓ **Backward:** Pull the handle backward, the attachment will turn counter-clockwise or the attachment cylinders back.

•**Neutral:** Attachment handle is on idle position, hydraulic pressure is relieved.



WARNING: Do not attach or remove the hydraulic attachments unless the attachment handle is on idle position and the hydraulic pressure is relieved.

Left Handhold

Hold the left handhold with left hand when operating left handle.



WARNING: Always close upon the handhold when operating the machine.

Left Handle

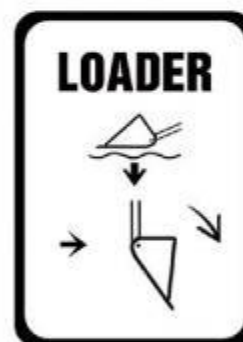
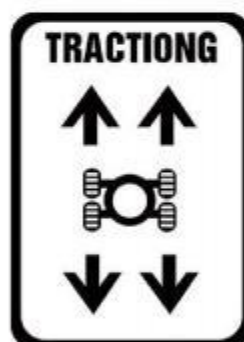
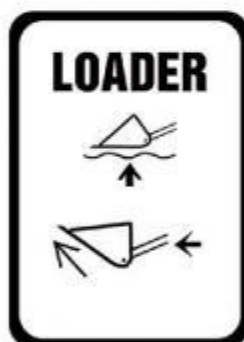

Forward: Move the handle forward, the left side tires will move forward, the machine will turn right.

Backward: Move the handle backward, the left side tires will move backward, the machine will turn left.

Leftward: Moving the handle toward the left side of the machine will dump the bucket.

Rightward: Moving the handle toward the right side of the machine will curls the bucket backward the operator.

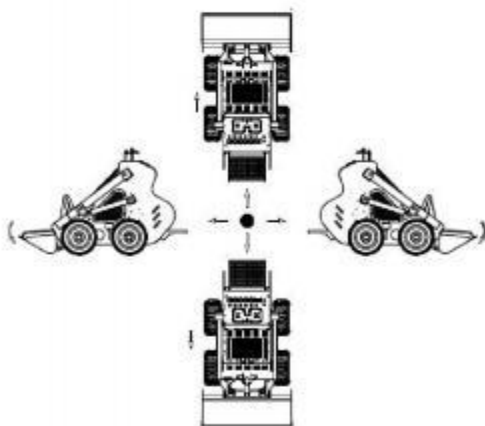

10/11/12. Head light, oil cooler button and USB interface

Press the A/C button to activate the cooling fan when Temp high.

Press the light button to turn on the head light.

USB external interface: output voltage 5V



13. Hand Throttle

Direction: Turn left→ Increase (Rabbit)

Turn right→ Decrease (Turtle)

Press the red button, pull up the throttle, and speed up engine;

Press the red button; push down the throttle, lower engine speed;

Loose the lock button, throttle lock automatically.



14. Engine starting Switch



OFF



ON



START

OFF: Engine stop

ON: Power on

START: Turn the key clockwise to start engine; release it to "ON" position after starting.

If the engine can not start, turn key to "OFF" position, wait a while (10~15s) and restart.

15. Power switch



Screw in



Switch on the power



cover the plug cover

Back out: Cut off the power



working.

CAUTION: *Make sure the electric power is off when the machine stops*

Cover the plug cover in order to avoid dust.

Screw in: Switch on the power



CAUTION: *Open the electric power before starting the engine.*

16) . Fuel Level Gauge

fuel level indication



VIII. Preparation before Work

1. Overview

A successful job begins before the job starts. The first step is to review all information of the job and jobsite.

2. All Jobs

2.1 Review working plan

Review blueprint or other working plan; check any possibility in current or planning process.

2.2. Arrange Traffic Control

Contact with local Security or Regulation authorities when working on road or other traffic area.

2.3. Emergency Service Plan

Check the phone number of local emergency treatment and first-aid department, and keep it.

2.4 Ground-Penetrating Jobs

Notify One-Call Services

Call area One-Call or similar services and have existing lines located and marked. Call any utilities in your area that do not subscribe to One-Call.

2.5 Above-Ground Jobs

Locate Overhead Lines

Note location and height of all overhead lines in jobsite and ensure that fully lifted attachment and/or load will not touch lines.

2.6 Inspect Site

Inspect jobsite before transporting equipment. Check for the following:

- changes in elevation such as hills or other open trenches
- obstacles such as buildings, railroad crossings, or streams
- Signs of utilities
- traffic
- access
- soil type and condition

2.7 Identify Hazards

Identify safety hazards and classify jobsite if attachment will penetrate ground. See "Classify Jobsite" on page 26.



WARNING

Jobsite hazards could cause death or serious injury. Use correct equipment and work methods. Use and maintain proper safety equipment

NOTICE:

Wear personal protective equipment including hard hat, safety eye wear, and hearing protection.

Do not wear jewelry or loose clothing.

Notify One-Call and companies which do not subscribe to One-Call.

Comply with all utility notification regulations before digging or drilling.

Verify location of previously marked underground hazards.

Mark jobsite clearly and keep spectators away.

Remember, jobsite is classified by hazards in place -- not by line being installed

3. Classify Jobsite

3.1 Inspect Jobsite

- Inspect jobsite and perimeter for evidence of underground hazards, such as:
 - “buried utility” notices
 - utility facilities without overhead lines
 - gas or water meters
 - junction boxes
 - drop boxes
 - light poles
 - manhole covers
 - sunken ground
- Follow Labor regulations on excavating and trenching and other similar regulations.
- Contact One-Call and any utility companies which do not subscribe to One-Call.
- Have an experienced locating equipment operator sweep area within 20’ (6 m) to each side of work path. Verify previously marked line and cable locations.
 - Mark location of all buried utilities and obstructions.
 - Classify jobsite.

3.2 Select a Classification

Jobsites are classified according to underground hazards present.

If working . . .	then classify jobsite as . . .
within 10’ (3 m) of a buried electric line	electric
within 10’ (3 m) of a natural gas line	natural gas
in sand, granite, or concrete which is capable of producing crystalline silica (quartz) dust	crystalline silica (quartz) dust
within 10’ (3 m) of any other hazard	other

NOTICE: If you have any doubt about jobsite classification, or if jobsite might contain unmarked hazards, take steps outlined previously to identify hazards and classify jobsite before working.

3.3 Apply Precautions

Once classified, precautions appropriate for jobsite must be taken.

3.3.1 Electric Jobsite Precautions

Use one or both of these methods.

Expose line by careful hand digging or soft excavation.

Have service shut down while work is in progress. Have electric company test lines before returning them to service.

3.3.2 Natural Gas Jobsite Precautions

In addition to positioning equipment upwind from gas lines, use one or both of these methods.

Expose lines by careful hand digging or soft excavation.

Have gas shut off while work is in progress. Have gas company test lines before returning them to service.

3.3.3 Crystalline Silica (Quartz) Dust Precautions

Follow OSHA or other guidelines for exposure to crystalline silica when trenching, sawing or drilling through material that might produce dust containing crystalline silica (quartz).

3.3.4 Other Jobsite Precautions

You may need to use different methods to safely avoid other underground hazards. Talk with those knowledgeable about hazards present at each site to determine which precautions should be taken or if job should be attempted.

4. Check Supplies and Equipment

4.1 Supplies

Fuel

Key

Lubricating oil

Personal safety equipment, such as safety helmet and goggles, etc.

4.2 Liquid level

Fuel

Hydraulic oil

Battery

Engine oil

4.3 Conditions and Marks

Filters (Air, fuel and oil)

Tires

Pump and motor

Hose and valve

Marks, warnings and shield

4.4 Accessory

If possible, add a fire extinguisher, but keep it away from any fire; the fire extinguisher should be applicable in both oil and electric fire. It should meet legal and regulatory requirements.

IX. Connect Attachments

IMPORTANT: Use approved attachments only. Attachments can change the stability and operating characteristics of the machine.

Attachments

IMPORTANT:

Make sure it is free of dirt before connecting attachment.

1. Make sure the lock pin handles (shown) on mount plate are turned away from center of attachment.
2. Start engine
3. Tilt mount plate forward
4. Put mount plate in the upper lip of receiver plate on attachment
5. Raise lift arms while tilting back mount plate.

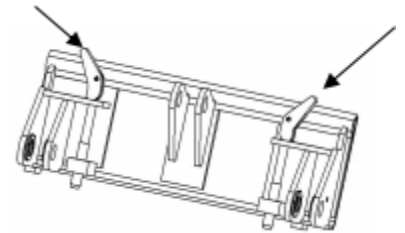
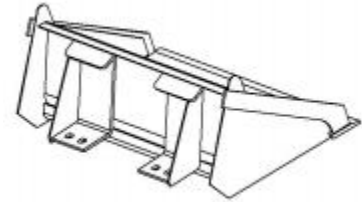

NOTE: Attachment should be raised enough to clear the ground. Mount plate should be tilted back fully.

6. Ensure all controls are in neutral position
7. Turn off the switch and remove the key
8. Rotate lock pin handles toward center of mount plate to secure attachment to lift plate.

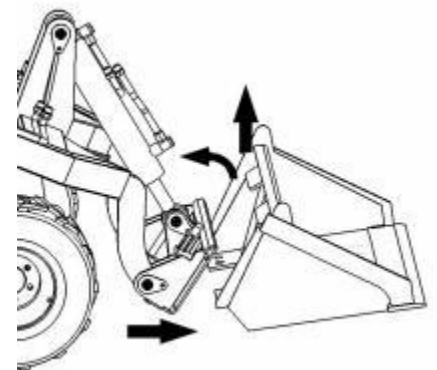

NOTICE : To ensure proper connection, verify that bottoms of lock pins are visible under attachment receiver plate.

Hydraulic Hoses

If attachment requires hydraulic power for operation, connect hydraulic hose.



WARNING: Fluid or air pressure could pierce skin and cause injury or death. Keep away.

NOTICES:

1. Escaping pressurized fluid can cause injury or pierce skin and poison.
2. Before disconnecting a hydraulic line, turn engine off and operate all controls to relieve pressure. Lower, block, or support any raised component with a hoist. Cover connection with heavy cloth and loosen connector nut slightly to relieve residual pressure. Catch all fluid in a container.

3. Before using system, check that all connections are tight and all lines are undamaged.
4. Fluid leaks can be hard to detect. Use a piece of cardboard or wood, rather than hands, to search for leaks.
5. Wear protective clothing, including gloves and eye protection.
6. If you are injured, seek immediate medical attention from a doctor familiar with this type of injury.



CAUTION: Hot parts may cause burns, do not touch until cool.

CAUTION: Hydraulic couplers, hoses and fluid may be hot. Wear gloves when connecting and disconnecting hydraulic hoses and wait until unit has cooled before touching hydraulic components.

1. Cycle attachment drive control to relieve residual pressure at hydraulic couplers.
2. Ensure that all controls are in neutral position.
3. Remove dirt and debris from hydraulic couplers.
4. Connect male coupler on attachment to female coupler on unit.
5. Connect coupler on attachment to male coupler on unit.
6. Connect female coupler on case drain hose to case drain coupler on unit, if attachment requires it.
7. Ensure that connections are secure by pulling on hoses.



X. Drive

1. Start Engine

- 1.1 Ensure all controls are in neutral.
- 1.2 If necessary, choke cold engine.
- 1.3 Move throttle to half open.
- 1.4 Turn ignition switch to start position and release when engine starts.
- 1.5 Push in choke after engine is warm.

Emergency shutdown: Turn ignition switch to STOP.

2. Drive General Operation

- 2.1 Pull lift arm control to raise mount plate (and attachment) off ground.
- 2.2 Move both wheel drive controls to forward or reverse.
- 2.3 Adjust throttle as needed.

3. Slope Operation Guidelines

3.1 **NOTE** : Keep attachment/load low when operating on a slope. Drive slowly and cautiously at all times.

3.2 Operate up and down slopes with heavy end of unit uphill. Weight distribution changes based on attachments and load. For example, an empty bucket makes the rear of the unit the heavy end while a full bucket makes the front of the unit the heavy end. Most KINGDOM-approved attachments make the front of the unit the heavy end.

-Avoid starting, stopping, or turning on slopes. If you must turn, keep the heavy end of the unit uphill.

-Do not park unit on slope without lowering attachment to the ground, returning all controls to neutral position, turning ignition switch to STOP, and applying parking brake.

4. Shut Down

- 4.1 Lower lift arms to ground.
- 4.2 Move all controls to neutral position.
- 4.3 Run engine at low idle for three minutes to cool.
- 4.4 Turn ignition switch to STOP.
- 4.5 Remove key.

CAUTION:

Unit should not be parking on a slope unless parking brake is engaged.

Move all controls to neutral position when stopped.



Warning

On slope, the angle of inclination should be no more than 12 °; Otherwise fuel will be leak.

X I . Machine Storage

1. Rinse Equipment



1.1 Spray water onto equipment to remove dirt and mud, especially at undercarriage.

CAUTION: Do not spray water onto operator's console. Electrical components could be damaged. Wipe down instead.

1.2 Open hood and remove debris from inside of unit.

1.3 Remove mud from wheel.

2. Disconnect Attachments

2.1 Lower attachment to the ground.

2.2 Ensure that all controls are in neutral.

2.3 Turn off engine.

2.4 Disengage lock pins by turning handles away from center of attachment.

2.5 Cycle attachment drive control and disconnect hydraulic hoses, if used.

2.6 Release park brake.

2.7 Start engine.

2.8 Tilt mount plate forward and back unit away from attachment.

3. Stow Tools

Make sure all tools and accessories are loaded on trailer.

X II. Safety Service & Maintenance

(一) Safety Service Precautions

1.  **WARNING** : Incorrect procedures could result in death, injury, or property damage.

Learn to use equipment correctly.

CAUTION:

Unless otherwise instructed, all maintenances should be performed with engine off.
Stop engine and apply parking brake before opening hood for inspection or service.
Allow engine to cool before performing any maintenance.

Refer to engine manufacturer's manual for engine maintenance instructions.

Before maintaining equipment, lower unstowed attachments to ground.

2. Working Under Raised Lift Arms



WARNING Crushing weight could cause death or serious injury.
Use proper procedures and equipment or stay away.

CAUTION: Support both lift arms before working under raised lift arms.



WARNING Explosion possible. Serious injury or equipment damage could occur. Follow directions carefully.

CAUTION:

1. Sparks can cause battery to explode.
2. Electronic components can be easily damaged.

(二) Maintenance

1. Lubricants

Proper lubrication and maintenance protects equipment from damage and failure. Service intervals listed are for minimum requirements. In extreme conditions, service machine more frequently. Use only recommended lubricants.

CAUTION:

1. Use only genuine KINGDOM parts, filters, and approved lubricants to maintain warranty.
2. Use the "Service Record" to record all required service to your machine.

Lubrication Area

Lubricating below areas before work

Clean before lubricating to avoid any dust or dirt.

Replace the parts if it is lost or damaged.

Avoid immoderate lubrication and try to reduce accumulation of dust.

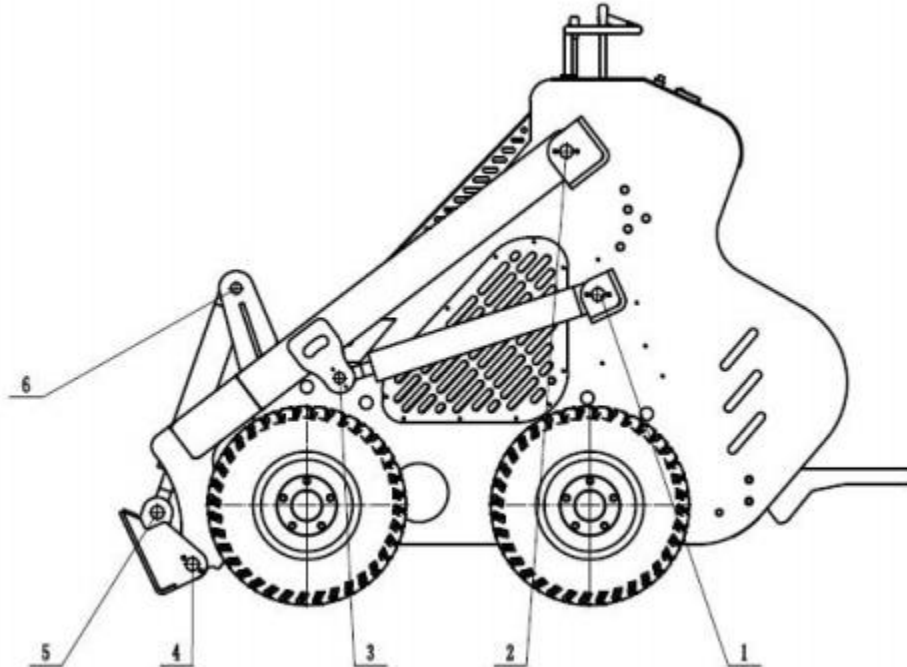

Chain Lubrication

Add lubricating oil at the plate break of inside and outside edge of chain regularly.

Use grease lubricants if oil lubricants not work in bad condition.

Engine Oil Temperature Chart

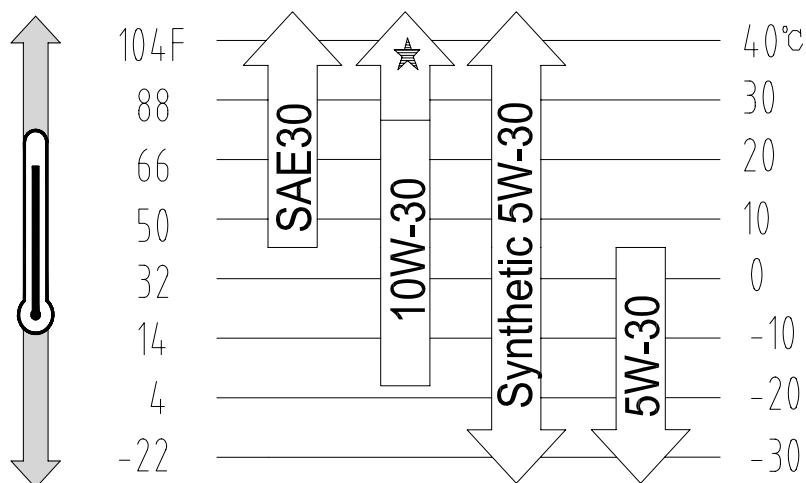

For more information on engine lubrication and maintenance, see your engine manual.

2. Maintenance

10 Hour

Check Engine Oil Level

Check engine oil level at dipstick opening every 10 hours. Oil level should be at top of marking, if low, add 10W30. Check with unit on level surface and at least 15 minutes after stopping engine.

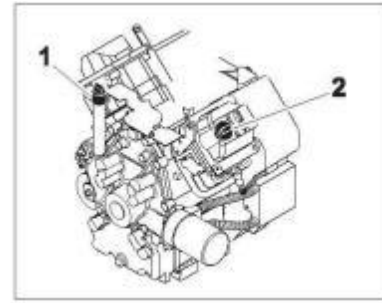

IMPORTANT: Use oil specified in “Engine Oil Temperature Chart”

Check Hydraulic Fluid Level

Check hydraulic fluid level every 10 hours.

Maintain fluid level at halfway point on gauge, when engine is off and fluid is cool. If low, add THF at fill

Check Hydraulic Hoses

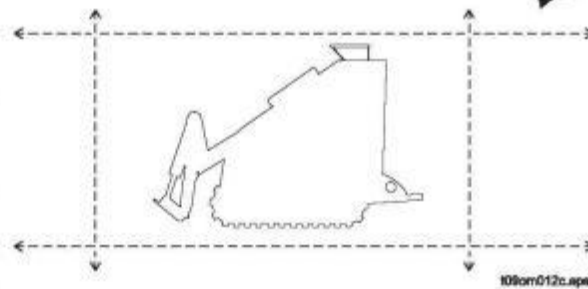
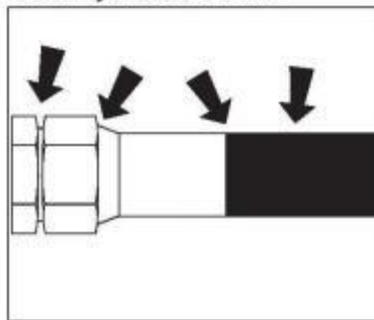

Check hydraulic hoses for leaks every 10 hours.



WARNING: Fluid or air pressure could pierce skin and cause injury or death. Keep away.

NOTICE:

1. Escaping pressurized fluid can cause injury or pierce skin and poison.
2. Before disconnecting a hydraulic line, turn engine off and operate all controls to relieve pressure. Lower, block, or support any raised component with a hoist. Cover connection with heavy cloth and loosen connector nut slightly to relieve residual pressure. Catch all fluid in a container.
3. Before using system, check that all connections are tight and all lines are undamaged.
4. Fluid leaks can be hard to detect. Use a piece of cardboard or wood, rather than hands, to search for leaks.

5. Wear protective clothing, including gloves and eye protection.
6. If you are injured, seek immediate medical attention from a doctor familiar with this type of injury.

50 Hour



Location	Task	Remarks
Drive	Check battery	
	Check drive belt	
	Check air filter	
	Check oil cooler	
	Check hydraulic filter	

Check Battery

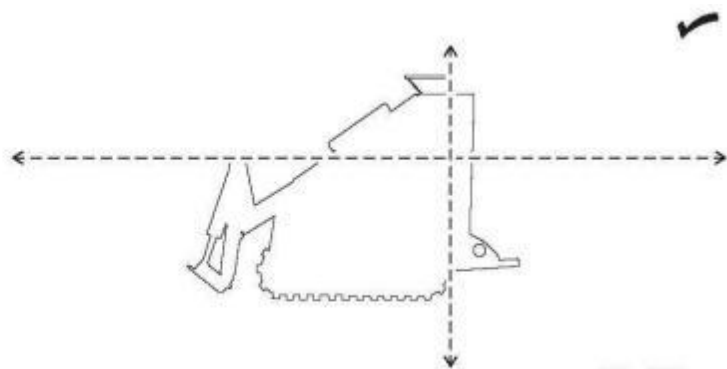
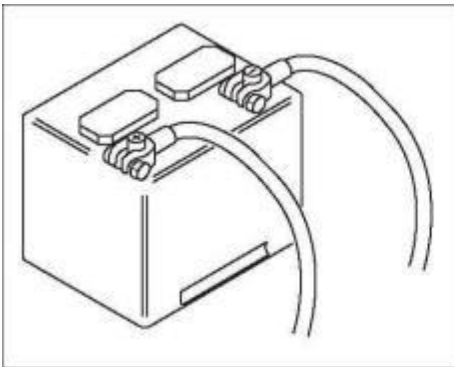

t17cm016h.eps

(1) Ordinary Battery: Check electrolyte when drive 10d~15d(d is day) in Winter and 5d~6d in Summer.

Disconnect its wires, open the cover and check electrolyte of each unit.

Fill in distilled water if it is below bottom level.

Maintenance-free Battery: Check the battery every 50 hours, keep battery and terminals clean and free of corrosion.

Check the hydrometer regularly, as it will change color along with electrolyte capacity, and it shows battery electricity condition and height of electrolyte level. When it shows green, battery is full of electricity and works well; if it is lack of green or shows dark, battery needs to be recharged; when it shows light yellow, indicating battery has internal fault, and it shall be repaired or replaced.

(2) Battery Storage & Service: Put the battery in shady and cool place, never put it directly in the sun exposure, and avoid moisture.

Do not knock battery with metal tools during installation, and do not put metal tools on the battery either.

- (3) Install and Dismount Battery:** Turn off engine, remove key.
Disconnect cathode wire first and then anode wire.
Loosen the bolt, and take out battery.
Confirm the electrode on battery.
Procedure of install battery is contrary to dismount.

NOTICE: Make sure connect with the right wire.

(4) Battery Operating Considerations:

1. Wear safety appliance (protective glasses, rubber gloves) when operating battery.
2. Do it carefully, as acid inside battery.
3. Clean it up immediately when drops acid on your skin or clothes; otherwise it will result in bad injury or death.
4. Keep the battery away from fire and heat sources.
5. Battery is used for starting engine only; otherwise it may cause battery damage or fire due to hydrogen out from the battery.

(5) Battery in Winter:

Do not let battery electricity leakage.

Do not restart when you failed once to start engine; Wait a minute to supply voltage.

NOTICE: Check and maintain the battery wires especially in Winter.



WARNING

Explosion possible. Serious injury or equipment damage could occur.
Follow directions carefully.

NOTICE:

- Battery gas can explode. Keep sparks and flames away from battery.
- Always remove negative (-) battery cable first and replace it last.
- Battery electrolyte is sulfuric acid and poisonous. Will burn skin and cause blindness if splashed into eyes. Wash hands after working around battery.
- Never disconnect battery terminals with engine running. Voltage spike may occur and ruin electronic control modules or other components.

Check Drive Belt

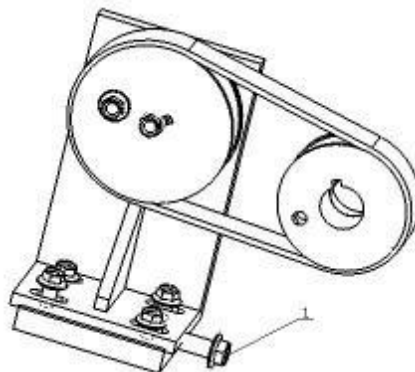

Check drive belt every 50 hours. Adjust belt tension if necessary. Replace if cracked, stretched, or badly worn.

Check Air Filter

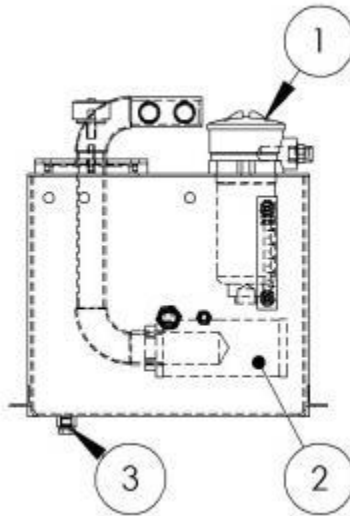

Check air filter for wear or holes every 50 hours. Replace as needed.

Clean Oil Cooler

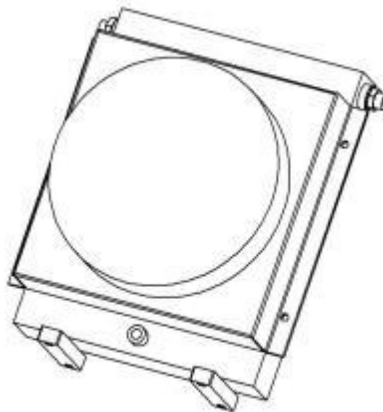

Clean oil cooler every 50 hours. Clean more frequently if operating in dusty conditions. Clean with compressed air or low pressure water.

NOTICE: Be careful not to damage cooler fins.

Change Hydraulic Fluid Filter (Break in only)

Change hydraulic fluid filter at 50 hours for break in process, then change every 250 hours.

100 Hour

Change Engine Oil

Change engine oil every 100 hours. Drain oil at drain plug (D) and add GEO 10W30 at filler

(C) until oil level is seen at marking B.

IMPORTANT: Use oil specified in “Engine Oil Temperature Chart”

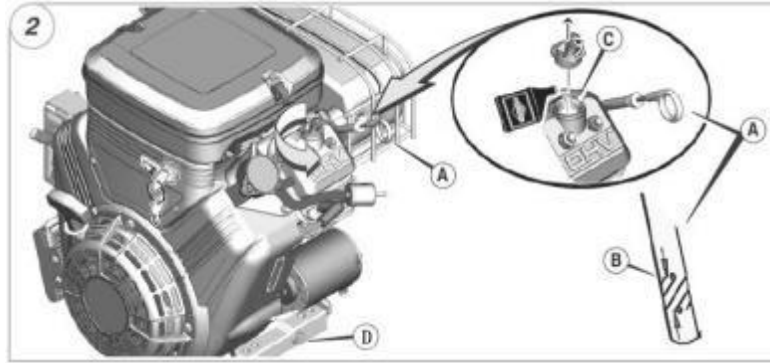

200 Hour

Check Spark Plugs and Gap

See engine operator’s manual for instructions.

Change Oil Filter

Change hydraulic fluid filter every 200 hours.

250 hour



Location	Task	Remarks
Traction unit	Change hydraulic fluid filter	
	Change air filter, check inner element	

Change Hydraulic Fluid Filter (2)

Change hydraulic fluid filter every 250 hours (1)

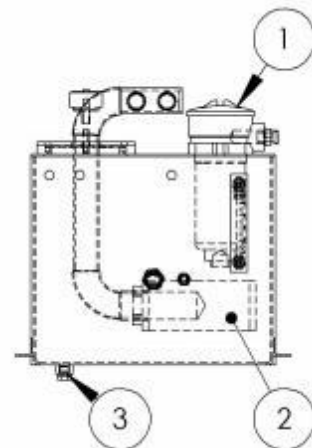

500 hours

Change Hydraulic Fluid

Change hydraulic fluid every 500 hours. Drain fluid at drain

plug (3) and add THF at filler (1) unit fluid level is at halfway point on sight glass (2). Then start engine, running idle for 2 minutes, then check the gauge and make sure the level is in the middle of gauge.

As needed

Location	Task	Remarks
Traction unit	Change drive belts	
	Jump start	

Change Drive Belt

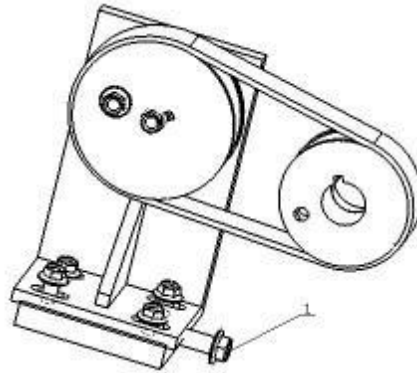

Change drive belt as needed when worn or damaged.



WARNING

Hot parts may cause burns. Do not touch until cool.

NOTICE: Allow engine to cool before touching parts or performing any service.

- 1 Stop engine and allow to cool before attempting service
- 2 Remove key from ignition switch.
- 3 Adjust belt tension.

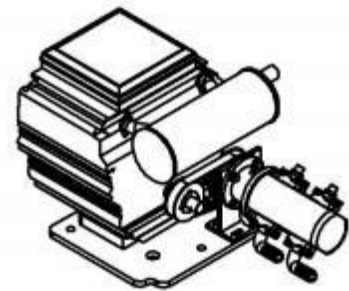

WARNING

Moving parts could cut off hand or foot. Stay away.

NOTICE: Do not open hood for inspection or service with engine running.



WARNING

Runaway possible. Machine could run over you or others. Learn how to use all controls. Start and operate only from operator's

position.

NOTICE: Do not leave operator station with engine running.

- 1 Start engine and check operation.
- 2 Stop engine open hood, and re-check belt alignment.
- 3 Close hood.

Jump Start Unit



WARNING Incorrect procedures could result in death, injury, or property damage.

Use equipment correctly.

NOTICES:

- 1 Park on level area
- 2 Put all drive controls in neutral
- 3 Lower all unstowed attachments
- 4 Turn off all electrical loads
- 5 Turn off engine and remove key from ignition
- 6 Block wheels or tracks



WARNING Explosion possible. Serious injury or equipment damage could occur.

Follow instructions to operate carefully.

CAUTIONS:

- 1 Lead-acid batteries vent explosive hydrogen gas when charging.
- 2 Do not smoke, create sparks, or use flames around batteries.
- 3 Never lean over battery when making connections.
- 4 Do not allow vehicles to touch when jump starting.
- 5 Wear eye protection and remove metal jewelry and watches.
- 6 Do not attempt to jump start a battery that is leaking, bulging, heavily corroded, frozen, or otherwise damaged.
- 7 Never short-circuit battery terminals for any reason.
- 8 Never hammer on battery posts or cable terminals.

Before You Start

Electronic components can be easily damaged by electrical surges. Jump starting can

damage electronics and electrical systems, and is not recommended except in extreme circumstances. Use quality large diameter jumper cables capable of carrying high currents (400 amps or more). Cheap cables may not allow enough current flow to start a dead/discharged battery.

Read all steps thoroughly and review illustration before performing procedure.

3. Decals



⚠ DANGER

Moving digging teeth will kill you or cut off arm or leg. Stay away.



⚠ DANGER

Turning shaft will kill you or crush arm or leg. Stay away.



⚠ DANGER

Electric shock. Contacting electric lines will cause death or serious injury. Know location of lines and stay away.



⚠ DANGER

Deadly gases. Lack of oxygen or presence of gas will cause sickness or death, provide ventilation.



⚠ WARNING

Jobsite hazards could cause death or serious injury. Use correct equipment and work methods. Use and maintain proper safety equipment



⚠ WARNING

Crushing weight could cause death or serious injury. Use proper procedures and equipment or stay away.



⚠ WARNING

Moving parts could cut off hand or foot. Stay away.



⚠ WARNING

Explosion possible. Serious injury or equipment damage could occur. Follow directions carefully.



⚠ WARNING

Incorrect procedures could result in death, injury, or property damage. Learn to use equipment correctly.



WARNING

Improper control function could cause death or serious injury. If control does not work as described in instructions, stop machine and have it serviced.



WARNING

Looking into fiber optic cable could result in permanent vision damage. Do not look into ends of fiber optic or unidentified cable.



WARNING

Fluid or air pressure could pierce skin and cause injury or death. Stay away.



WARNING

Runaway possible. Machine could run over you or others. Learn how to use all controls. Start and operate only from operator's position.



WARNING

Fire or explosion possible. Fumes could ignite and cause burns. No smoking, no flame, no spark.



WARNING

Moving traffic - hazardous situation. Death or serious injury could result. Avoid moving vehicles, wear high visibility clothing, post appropriate warning signs.



WARNING

Flying objects may cause injury. Wear hard hat and safety glasses.

Hot parts may cause burns. Do not touch until cool.



WARNING

Exposure to high noise levels may cause hearing loss. Wear hearing protection.



WARNING

Fall possible. Slips or trips may result in injury. Keep area clean.



WARNING

Battery acid may cause burns. Avoid contact.



WARNING



WARNING

Improper handling or use of chemicals may result in illness, injury, or equipment damage. Follow instructions on labels and in material safety

data sheets (MSDS).

Emergency Procedures

Before operating any equipment, review emergency procedures and check that all safety precautions have been taken.

EMERGENCY SHUTDOWN - Turn ignition switch to STOP.

Electric Strike Description

When working near electric cables, remember the following:

Electricity follows all paths to ground, not just path of least resistance.

Pipes, hoses, and cables will conduct electricity back to all equipment.

Low voltage current can injure or kill. Almost one-third of work-related electrocutions result from contact with less than 440 volts.

Most electric strikes are not noticeable, but indications of a strike include:

power outage

smoke

explosion

popping noises

arcing electricity

If any of these occur, assume an electric strike has occurred.

If an Electric Line is Damaged

If you suspect an electric line has been damaged and you are on loader, DO NOT MOVE. Remain on it and take the following actions. The order and degree of action will depend upon the situation.

Warn people nearby that an electric strike has occurred. Instruct them to leave the area and contact utility.

Raise attachments and drive from immediate area.

Contact utility company to shut off power.

- Do not return to jobsite or allow anyone into area until given permission by utility company.

If you suspect an electric line has been damaged and you are off loader, DO NOT TOUCH LOADER. Take the following actions. The order and degree of action will depend upon the situation.

LEAVE AREA. The ground surface may be electrified, so take small steps with feet close together to reduce the hazard of being shocked from one foot to the other. For more information, contact your dealer.

Contact utility company to shut off power.

Do not return to jobsite or allow anyone into area until given permission by utility company.

If a Gas Line is Damaged

If you suspect a gas line has been damaged, take the following actions. The order and degree of action will

depend on the situation.

Immediately shut off engine(s), if this can be done safely and quickly.

Remove any ignition source(s), if this can be done safely and quickly.

Warn others that a gas line has been cut and that they should leave the area.

Leave jobsite as quickly as possible.

Immediately call your local emergency phone number and utility company.

If jobsite is along street, stop traffic from driving near jobsite.

Do not return to jobsite until given permission by emergency personnel and utility company.

If a Fiber Optic Cable is Damaged

Do not look into cut ends of fiber optic or unidentified cable. Vision damage can occur.

If Machine Catches on Fire

Perform emergency shutdown procedure and then take the following actions. The order and degree of action will depend on the situation.

Immediately move battery disconnect switch (if equipped) to disconnect position.

If fire is small and fire extinguisher is available, attempt to extinguish fire.

If fire cannot be extinguished, leave area as quickly as possible and contact emergency personnel.

XIII. Main Specifications

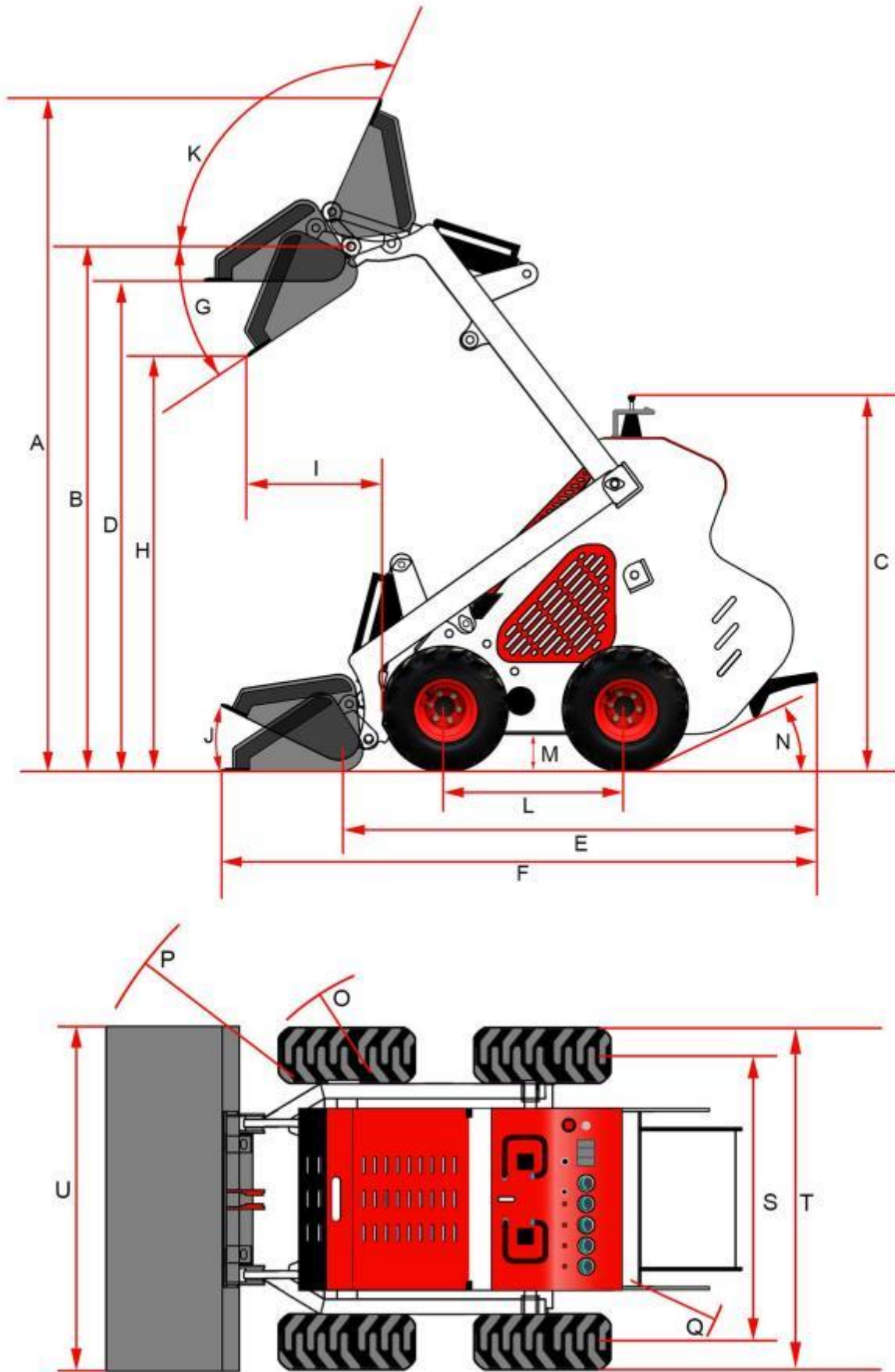

MAIN SPECS		MODEL	T15
A	Max. operating height (mm)		2452
B	Height to bucket hinge pin (mm)		1914
C	Height (mm)		1370
D	Height to bottom of level bucket (mm)		1790
E	Overall length without bucket (mm)		1740
F	Overall length with bucket (mm)		2170
G	Dump angle (°)		33.7
H	Dump height (mm)		1515
I	Dump reach (mm)		545
J	Rollback angle of bucket on ground (°)		26
K	Rollback angle of bucket at full height (°)		114
L	Wheelbase (mm)		657
M	Ground clearance (mm)		140
N	Angle of departure (°)		23
O	Front turning radius without bucket (mm)		801
P	Front turning radius (mm)		1282
Q	Rear turning radius (mm)		1026
S	Tread width (mm)		960
T	Overall width (mm)		740
U	Bucket width (mm)		830

X IV . **SUPPORT**

For any questions, spare parts or warranty claims, please complete the form at

<https://aftersalescare.com.au/support/>