

DIGGERKING

SUPER BARRROW 890



OPERATOR'S MANUAL

DIGGERKING.COM.AU



This symbol indicates a safety warning.

The information immediately following the symbol contains important safety information.

Please read and understand this information to avoid personal injury or death.

It is the responsibility of the machine owner or employer to guide each Bitwise operation to operate all equipment correctly and safely. All personnel using this machine should be fully familiar with the content of this manual.

Before operating the machine, all operators must receive guidance on the relevant functions of the crawler dumper vehicle.

Before operating this machine on the construction site, you should learn and practice how to use machine control correctly in a safe and open place.

Improper operation, inspection, and maintenance of the machine can lead to injury or death.

Please read and understand this manual before performing any operation, inspection, or maintenance on the machine.

Make sure to carry this manual with you, preferably on the machine. If the manual is lost or damaged, please order a new one from your dealer immediately.

When transferring this machine to someone else, please make sure to hand over this manual to the new owner.

SIGNAL WORD

The safety instructions appearing in this manual and on the machine identification are cautioned with words such as "danger", "warning", and "caution". The meanings of these signal words are as follows:



Danger "refers to a high degree of danger that, if not avoided, could result in death or serious injury.



Warning "refers to a moderate risk that, if not avoided, may cause
Death or serious injury.

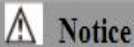

Attention "refers to a low level of danger that, if not avoided, may result in mild or moderate injury.

We cannot predict all possible dangerous situations. Therefore, the warnings in this manual or on the machine cannot cover all possible unexpected situations. Therefore, please be careful and follow all routine safety measures when operating the machine to avoid damage to the machine, operators, or other personnel.

INTRODUCE

PREFACE

This manual introduces the operation, inspection, and maintenance of the machine, as well as safety instructions that should be noted during operation.

If you have any questions about the machine, please contact Digger King Pty Ltd.

- In some details, this manual may differ from the manual provided with the machine you are using.
- Please note that the information and machine parameters in this manual are subject to change without prior notice.

Serial number

Important: Do not remove the machine nameplate with the serial number.

Check the serial numbers of the machine and engine and record them in the blank space below.

Machine number:

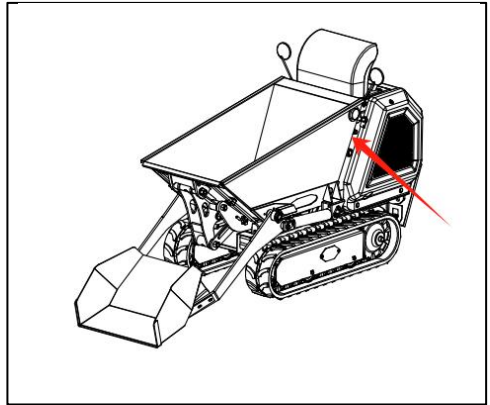

Engine number:

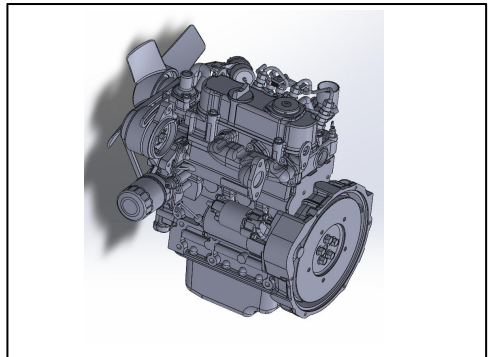

Machine Description

Front, Rear, Left, and Right

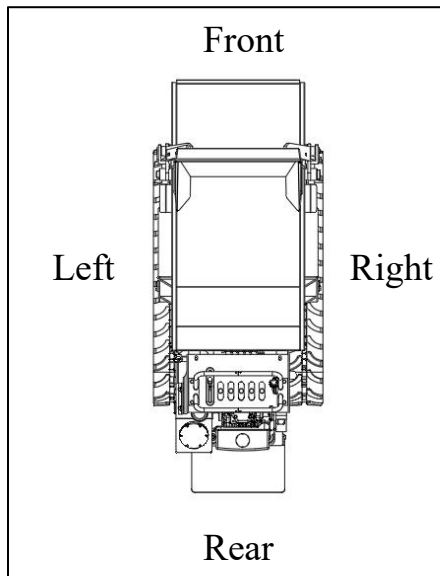

The front, rear, left, and right of the machine indicated in this manual refer to the visible state of the front shovel in the driving position.

Specify Action

This machine is mainly used for the following operations:

loading

Unloading/lifting unloading
transport

Product Features

Wide range of use, simple structure, stable transmission, and easy to achieve automation control

Suitable for complex road conditions such as swamps, riverbanks, deserts, paddy fields, tropical rainforests, snow, and ice.

High traction, good climbing and gripping performance, and strong transportation capacity.

Small turning radius, flexible maneuverability, especially suitable for narrow areas, reducing the cost of building roads.

Equipped with electric starting, centralized and convenient operation.

Equipped with hydraulic takeoff and landing, self unloading, reducing labor intensity and improving transportation efficiency.

REGULAR

Please follow the instructions below for the first 100 hours of the new machine (indicated by the hour meter):

Using a new machine without regular use can lead to accelerated performance degradation and may shorten the lifespan of the machine.

Fully preheat the engine and hydraulic oil.

Avoid overloading and fast operation. Maintain a load capacity of approximately 80% of its maximum load during operation.

Do not suddenly start, accelerate, change direction, or stop unless necessary.

Notes on reading this manual

Please note that the descriptions and charts contained in this manual may not be applicable to the machine you are using.

The numbers used in the illustration are circled around the markings. When the same number appears in text, it is marked with parentheses. (For example: ① → (1))

Marks used in this manual

The meanings of the symbols used in this manual are as follows.

⊘, ✕ ... 禁止 prohibit

🔒 ... 锁 lock

🔓 ... 解锁 Unlock

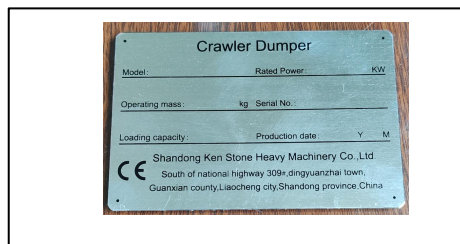
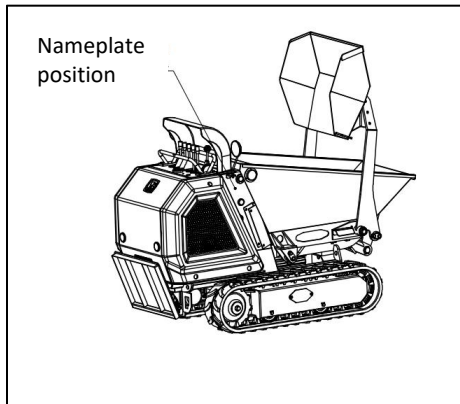

The nameplate of this model and its location on the entire machine, as shown in the above figure

DIRECTORY

Introduce.....	0-2	Operate the walking control lever.....	3-7
Machine Description.....	0-3	Stop walking.....	3-9
Secure.....	1-1	Operating the working device.....	3-10
General considerations.....	1-2	Operating procedures.....	3-12
Precautions during preparation...	1-8	Precautions for operation.....	3-12
Safety measures during start-up...	1-10	Precautions for driving on slopes.....	3-13
Precautions during operation.....	1-12	The operations that can be performed on this machine.....	3-14
Precautions when stopping.....	1-17	Stop the machine.....	3-15
Precautions during transportation	1-18	Parking.....	3-15
Precautions for maintenance.....	1-19	Check after turning off the engine.....	3-15
Safety signs (identification).....	1-27	Handling in cold climates.....	3-16
control	2-1	Preparation for Cold Climate.....	3-16
Component Name (XN800-D722).....	2-2	Precautions after operation.....	3-16
Starting key.....	2-4	After a cold climate.....	3-16
Fuel Cap.....	2-4	Handling rubber tracks.....	3-17
Switch.....	2-5	Ban.....	3-17
Start switch.....	2-5	Note.....	3-17
Power switch.....	2-5	Prevent rubber tracks from falling off	3-18
Rod and pedal.....	2-6	Transport	4-1
Throttle control lever.....	2-6	Loading and unloading.....	4-2
Controller.....	2-6	Lifting machine.....	4-3
Operate	3-1	Fixed machine.....	4-5
Before starting the operation.....	3-2	maintenance	5-1
Up and down machines.....	3-2	overview.....	5-2
Bypass inspection.....	3-2	Maintenance Overview.....	5-2
Daily routine inspection.....	3-2	Maintenance precautions.....	5-2
Starting and stopping the engine...	3-3	Service data.....	5-4
Before starting the engine.....	3-3	Fuel and lubricating oil gauge.....	5-4
Starting the engine.....	3-4	Regularly replace hydraulic oil.....	5-7
Turn off the engine.....	3-5	Consumable List.....	5-8
Operate the machine.....	3-6	Tools list.....	5-9
Operation diagram.....	3-6	Tightening torque list.....	5-10
		Safety critical components.....	5-11
		Maintenance List.....	5-13
		Bypass inspection.....	5-14

Inspect	5-14	Replace hydraulic oil and clean oil suction filter.....	5-30
Bypass the machine for inspection.....	5-14	when needed.....	5-32
Daily routine inspection.....	5-16	Lubrication rod.....	5-32
Check and replenish engine lubricating oil.....	5-16	Check rubber tracks.....	5-32
Check fuel level.....	5-16	Replacing rubber tracks.....	5-33
Check the hydraulic oil tank and replenish it.....	5-17	Maintenance during prolonged parking periods.....	5-35
Lubrication working device.....	5-18	Troubleshooting.....	6-1
Every 50 hours.....	5-20	If the battery is dead.....	6-2
Check and adjust the tension of the track.....	5-20	Other Symptoms.....	6-4
Check the battery level and replenish it.....	5-22	Common faults and troubleshooting methods of diesel engines.....	6-6
Every 200 hours.....	5-23	traction	6-8
Replace the engine lubricating oil and oil filter.....	5-23	Machine parameters.....	7-1
Clean the air filter.....	5-24	Basic parameters of XN800.....	7-2
Check the throttle control system.....	5-25	External dimensions of XN800.....	7-3
Replace the diesel filter.....	5-25		
Every 1000 hours.....	5-27		
Replace the air filter element.....	5-27		
Check and adjust the engine valve clearance.....	5-27		
Every 1500 hours.....	5-29		
Check and clean the engine fuel injector.....	5-29		
Every 2000 hours.....	5-30		

Safety





General Precautions

You are liable to abiding by the safety laws and regulations of relevant departments and fulfilling the operations, checking, and maintenance of machine.

As a matter of fact, all accidents are caused by the non-compliance with basic safety rules and precautions.

Most accidents can be avoided by authenticating the potential dangers in advance.

Please read and understand all safety

information related to the prevention of accidents. Please ensure to operate the machine only after you have understood how to operate, check, and maintain the machine correctly.

Abiding by All Safety Regulations

- The machine must be operated, checked, and maintained by trained and qualified personnel.
- During the operations, checking, and maintenance of machine, ensure to understand and abide by all rules, regulations, precautions, and safety measures.
- Do not operate, check, or maintain the machine under the adverse influence of alcohol, drug, medicine, or fatigue or

under sleepy status.

Upon detection of machine abnormality

During the operations, checking, or maintenance of machine, upon detection of any machine abnormality (Such as noise, vibration, smell, abnormal instrument, smoking or oil leakage, error warning indication, and abnormal display of electric control panel), immediately notify a sales or service dealer and take appropriate measure. Do not operate the machine before the abnormality is solved.

Operating Temperature Range

To maintain the performances and prevent the earlier wear of machine, please abide by the following operating conditions.

- Do not operate the machine when the outside temperature is more than +45°C or less than -15°C
- The operations under +45°C outside temperature will probably result in engine overheating and deteriorated engine performance. In addition, the hydraulic oil will probably become really hot to harm the hydraulic devices.
- The operations under 15°C outside temperature will probably harden the rubber parts (Such as gaskets) and cause earlier wear or damage of machine.
- To operate the machine under the



Wearing Appropriate Clothing and Protective Appliances



- Do not wear loose clothing or wear decorative articles that will probably hitch to any joystick or motion part.
- Do not wear oil or fuel contaminated clothing that is easily vulnerable to fire.
- As per the requirements of working environment, wear safety shoes, safety helmet, safety goggles, filtration mask, thick gloves, ear flaps, and other protective appliances. During the use of grinding miller, breaking hammer, or compressed air, please wear appropriate protective appliances, such as safety goggles and filtration mask, as the splashing of metal chippings or other objects will probably cause serious harms.
- Please use the hearing protection devices during the operations of machine. Exposure to a high noise environment for a long time will result in harm or even complete loss of hearing.

Installation of Fire Extinguisher and First-Aid Kit



Fulfill the preparations for fire and accident.

- Install the fire extinguisher and first-aid kit and learn how to use them.
- Learn how to extinguish fire and handle accident.
- Know how to contact emergency aid and fabricate the emergency contact list.

Do not remove safety devices when the battery is low



Setup of Signaler and Flagman



Learn how to use the gestures of specific operation needs and designate the person responsible for making gestures.

- All personnel must completely understand all gestures.
- The operator must respond to the gestures of designated person only. However, the operator must abide by the stop gesture made by anyone in all cases.
- The signaller must stand in a clearly visible place while making the gestures.

Precautions for Standing up from or Leaving Driver Seat

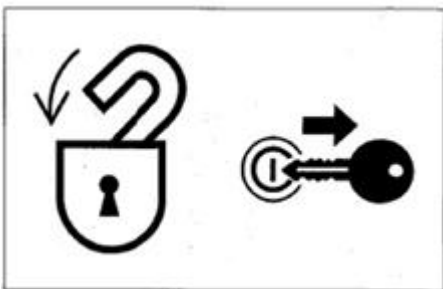

- Before standing up from the driver seat to open/close windows or disassemble/install the lower window, lower the working device onto the ground, lift up and lock the safety lock handle, and stop the engine. When the safety lock handle is lowered down (Unlocked), the accidental touch of any joystick will result in sudden movement of machine and cause serious



Guard against Fire and Explosion Dangers



Keep fuel, lubricating oil, grease, and antifreeze away from flame. The fuel is especially inflammable and really dangerous.

- Handle these inflammable away from ignited cigarette, match, lighter, and other flame or fire source.
- Do not smoke or use open fire while handling fuel or performing the operations of fuel system.
- Do not leave the operation site while filling fuel or lubricating oil.
- Do not disassemble the fuel tank cap or refuel while the engine is running or is not cooled down. In addition, do not splash fuel to any machine hot surface or electronic system part.
- Immediately clean the overflow fuel or lubricating oil thoroughly.
- Check for leakage of fuel and lubricating oil. Please eliminate the leaks and clean the machine before operations.
- Please move the inflammable to a safe place before polishing or welding operations.
- Please move the inflammable to a safe place before polishing or welding operations.
- Do not cut or weld any pipeline or pipe that probably contains inflammable liquid. Please clean thoroughly by non-inflammable solvent before cutting or welding.
- Remove all wastes and impurities from machine. Ensure that there is no oil contaminated rag or other inflammable on the machine.
- Handle all solvents and dry chemicals (Foam fire extinguisher) as per the manufacturer's procedures indicated on the containers. Operate in a well-ventilated place.
- Never use fuel for cleaning purpose. Always use non-inflammable solvent.
- Please open doors and windows for thorough ventilation during the handling of fuel and the cleaning of oil stain or paint.
- Preserve all inflammable liquids and materials in a safe and well-ventilated place.
- The short-circuit of electric system will probably result in fire. Daily check the wire connections for looseness and damage. Re-tighten loose connectors and cable clamps. Repair or replace damaged wires.
- Fire accident caused by pipelines: Ensure that the clamps, protection devices, and cushion pads of hoses and pipes are securely fixed. In event of looseness, the hoses and pipes will be damaged due to vibration or contact with other parts during operations. This will probably result in spray of high pressure oil to cause fire accident or harms.



Toxic Exhaust Gas from Engine



- Do not operate the engine in an enclosed place with poor ventilation.
- If the natural ventilation is not possible, install ventilation fan, fan, extended exhaust pipe, or other ventilation device.

Handling of Asbestos Powders

The inhalation of asbestos powders will probably cause lung cancer. While handling the materials probably containing asbestos, take the following safety measures:

- Do not sweep by compressed air.
- Avoid polishing or grinding asbestos-contained parts.
- During cleaning, use a vacuum device installed with high-efficiency particulate air filter (HEPA).
- If there is no other method for control of powders, please wear the specified respirator. During indoor operations, please install a ventilation system with polymer filter.

Be careful not to squeeze or cut



Do not place your hands, feet, or other body parts between the frame and the tipping bucket or between the tracks, between the tipping bucket and the front shovel, or between the oil cylinder and the moving parts. When the machine moves, the size of these gaps may change, which may cause serious injury or death.



Using option products

- Please consult Digger King Pty Ltd before installing the option. Depending on the type of attachment or their combination, the attachment may come into contact with other parts of the machine. Before use, please ensure that the installed options do not come into contact with other parts.
- Do not use attachments that have not been approved by Digger King Pty Ltd. Doing so may endanger safety or have adverse effects on the operation or lifespan of the machine.
- Digger King Pty Ltd shall not be responsible for any injury, accident, or product damage caused by the use of unauthorized attachments.

Do not modify the machine

- Unauthorized modifications to the machine can cause injury or death. Do not make unauthorized modifications to any part of the machine.



Precautions during preparation

Understand the work area

Before starting the operation, it is important to understand the situation in the work area to ensure safety.

Check the terrain and ground conditions of the work area. When working indoors, check the structure of the building and take safety measures if necessary.

Be sure to avoid hazards and obstacles such as ditches, underground pipelines, trees, cliffs, overhead power lines, or areas with falling rocks or landslides.

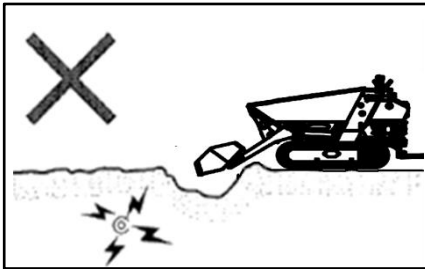

- Check the location of buried gas pipes, water pipes, and power cables with the administrator. If necessary, consult with the administrator and determine the specific security measures that must be taken to ensure security.
- When working on the road, it is important to consider the safety of pedestrians and vehicles.

- Using signalmen and/or signals
- Isolation work area, unauthorized personnel are not allowed to enter.
- When working in water or driving through shallow streams, it is necessary to check the depth of water, whether the ground is solid, and the speed of water flow in advance. Please refer to the "Precautions for Operation" for more usage instructions.

Check the strength of the bridge

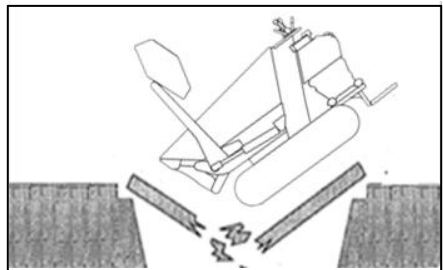

When walking on bridges or structures, please check the allowable load. If the strength is insufficient, the bridge or structure should be strengthened



Always keep the machine clean

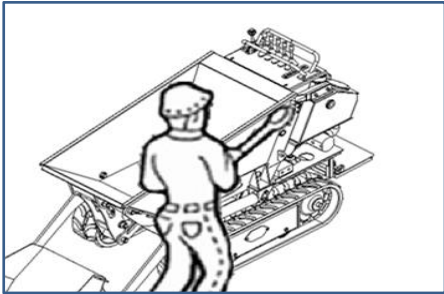

- Wipe off lubricating oil, grease, soil, snow or ice to prevent accidents caused by slipping.
- Eliminate all loose objects and unnecessary devices inside the machine.
- Eliminate dust, lubricating oil, or grease from engine parts to prevent fires.
- Clean the area around the operator seat and remove any unnecessary objects from the machine.

Conduct daily inspections and maintenance

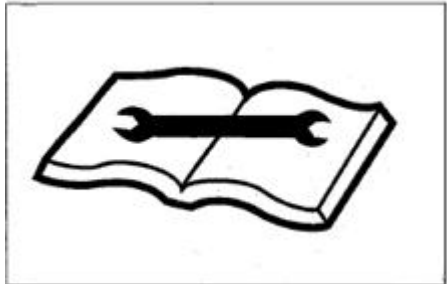

Failure to identify or repair abnormal conditions or damage to the machine can lead to accidents.

Before operation, please conduct designated inspections and repair immediately if necessary.

If a malfunction occurs and cannot be operated or the engine malfunctions, please immediately shut down the machine according to the shutdown procedure and firmly park the machine until the malfunction is repaired.



Before starting machine, keep all non-authorized personnel away from this zone

Start the engine only after the safe start is confirmed by checking the following items.

- Walk around the machine and alert the repair personnel and the personnel walking

around the machine. Start the engine only after it's confirmed that there is no person around the machine.



Start by Jumper Cable



Start by jumper cable only as per the recommended method. The improper use of jumper cable will result in battery explosion or unexpected machine motions.

Please refer to “In event of no battery power” to understand more operation description information.

After Start of Engine

After the start of engine, fulfill following operations and checking in a place without personnel or obstacle. Upon detection of any malfunction, stop the engine as per the

procedure and report malfunction.

Warm up the engine and hydraulic oil.

Check all instruments and warning devices for normal functioning.

Check for presence of noise.

Test the engine speed control.

Operate all control devices to ensure normal functioning.



For Cold Weathers



Take cautions that the frozen ground, footplates, and handrails are slip. Under cold weathers, do not touch any metal part of machine by bare hands. Your skin will be frozen on metal part to cause serious injuries.

Do not use ethyl ether or starting fluid on the engine. The starting fluid can cause explosion and serious injuries or deaths.

Warm up the engine and hydraulic oil.

Operating joysticks without warm-up will result in slow or inappropriate reaction or movement of machine to cause accident.

About vibration

The hand-arm vibration value is 2.5 m/s². The uncertainty of measurement is 0.5 m/s².

The whole-body vibration value is 0.5 m/s².

The uncertainty of measurement is 0.1 m/s².

Regarding noise

The A-weighted emission sound pressure level at the operator's station is 83 dB(A).

The uncertainty of measurement is 2.5 dB.

The A-weighted emission sound power level is 95 dB(A). The uncertainty of measurement is 1.5 dB. Measured according to 2000/14/EC.

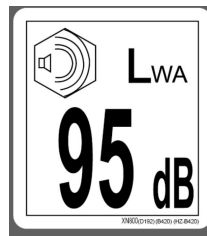



Precautions during operation

Ensure good visibility

Check the field of view before operating the machine

- When working in dark areas, install additional lighting equipment as necessary.
- When the visibility is poor due to adverse weather conditions (fog, snow, rain, or haze), the machine should be stopped from operating until the visibility improves.
- Unauthorized machine modifications or installation of unapproved attachments may affect visibility. The operator's field of view must comply with ISO 5006.

Do not carry people on the machine



All personnel are prohibited to sit on any part of machine at any time during traveling or operations of machine.

- Confirm the performance limits of the machine.
- At shoulders, narrow areas, or areas with obstructed vision, use signalmen.
- Do not allow anyone to enter the path of the machine.
- Before walking backwards in the blind spot, please check the safety behind and confirm that there is no one behind.

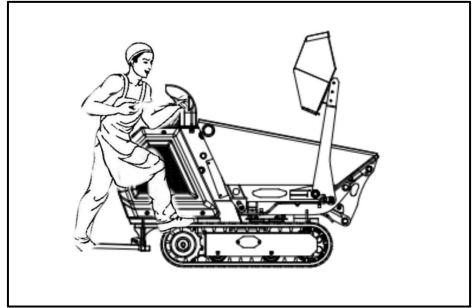

When operating the machine, to ensure driving safety, it is strictly prohibited to extend your feet over the track guard.

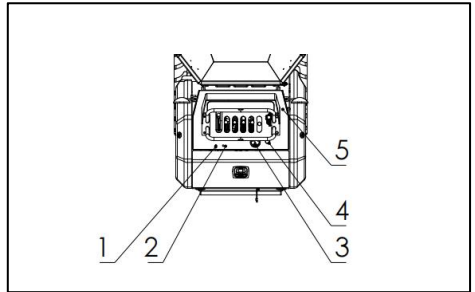

When operating, please pay attention to following the instructions on the control panel. The function corresponding to the serial number is

1. Turn off button
2. Horn button
3. Pay attention to all alarm indications on the instrument panel
4. Start the key switch
5. Lighting button

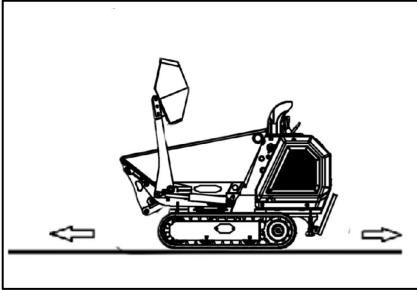

- When walking, the front shovel should be in a raised state and ensure that the tipping bucket is lowered to the limit position

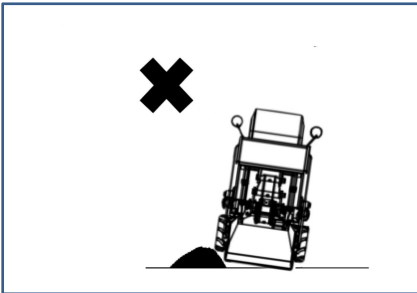

- Try to avoid crossing obstacles as much as possible. If this is necessary, walk slowly. Do not cross obstacles that will tilt the machine by 10° or more.
- On uneven roads, keep walking at low speed to avoid sudden starts, stops, or changes in direction. Otherwise, the working device may come into contact with the ground, causing the machine to lose balance and damage or damaging the structure in the surrounding area.

Precautions for driving on slopes

When walking up slopes or ramps, be careful not to overturn or slide the machine.

- Do not walk on steep slopes where the machine cannot maintain its stability. Please note that in practical use, the performance of the machine on slopes may decrease due to its harsh operating conditions.
- Keep the driver's seat facing the hill when climbing. When going downhill, keep the driver's seat facing the direction of the mountain. In both cases, it is necessary to pay attention to the ground in front of the machine when walking.
- In emergency situations, lower the front shovel to the ground and turn off the machine.
- When walking up slopes or ramps, it is necessary to drive slowly. Reduce engine speed when going downhill.

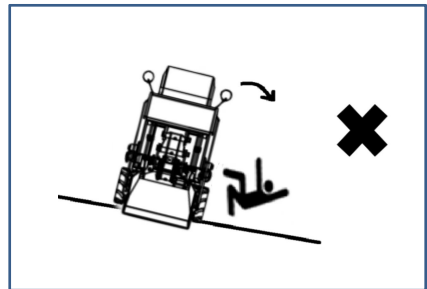

- Do not change direction on slopes or cross-slopes. First, return to the flat surface, and then select another path.
- When walking on gentle slopes covered with grass or dead leaves, or on wet metal plates or frozen ground, the machine may slip sideways. Ensure that the machine does not stop horizontally on a slope.
- If the machine stalls on a slope, please return each lever to the center position and restart the engine.



Operating the machine on snow or ice requires extra caution

- When walking on snow or icy ground, you should drive at low speed to avoid sudden starting, stopping, or changing direction.
- In snowy areas, objects placed on the shoulders and roadside are buried in the snow and cannot be seen. There is a risk of the machine overturning or colliding with covered objects, so always operate with caution.
- If the machine enters thick snow, there is a risk of overturning or being buried in the snow.
- Drive carefully and do not exceed the road shoulder or get trapped in snow.
- For frozen soil surfaces, when the temperature increases, the ground becomes soft, which may cause the machine to overturn and cause the operator to be trapped inside the machine.
- When parking the machine on unstable ground, lower the front shovel.

Do not move the front shovel above personnel's heads

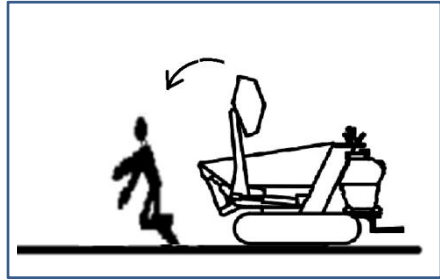

If the front shovel is moved above the person's head, there is a risk of the front shovel suddenly falling.

Ensure driver safety during loading

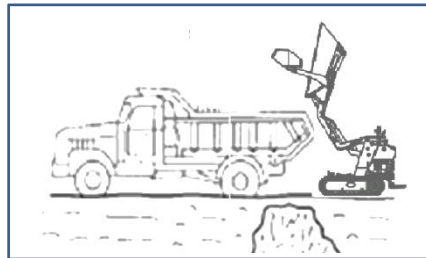

Do not load until the driver reaches a safe place.

Do not swing or park the bucket on personnel or the cab.

Pay attention to the vehicle position during loading.

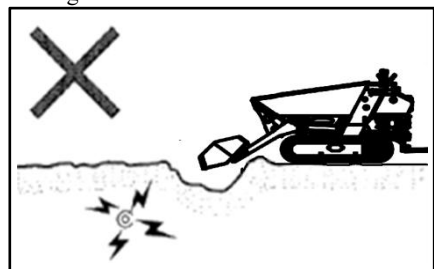

Please also pay special attention to high-voltage cables buried underground.



Pay close attention to hazardous working conditions

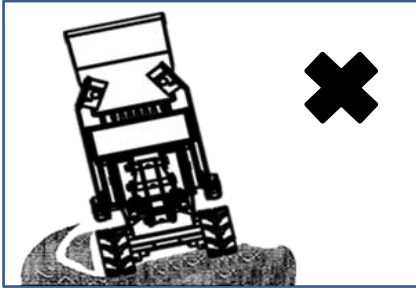

- Do not enter areas with soft ground. Doing so may cause the machine to tilt due to its own weight, causing it to overturn or sink into the ground.

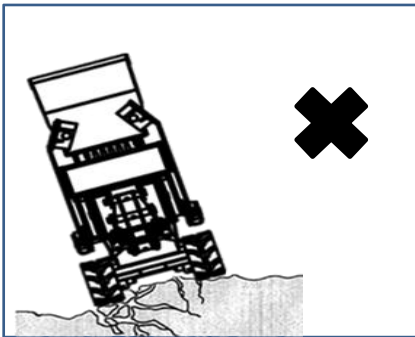

- Do not approach unstable ground (cliffs, shoulders, deep trenches). If the ground collapses due to machine weight or vibration, there may be a risk of the machine falling or overturning.
- Please remember that the soil is not strong after heavy rain or blasting.
- The top of the embankment and the top ground around the excavation ditch are also not solid.

Operating on slopes is very dangerous

When operating on slopes or ramps, reversing the direction may cause the machine to lose stability or overturn. Try to avoid operating on slopes as much as possible.

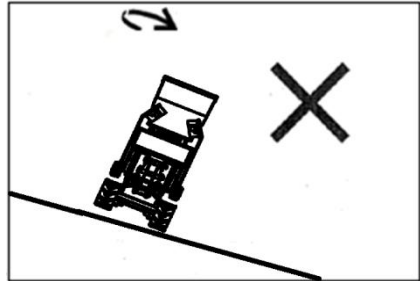

- When the tipping bucket is full of material, avoid turning towards the downhill direction. This will reduce the stability of the machine and may cause it to overturn.

Please pay attention to objects above your head

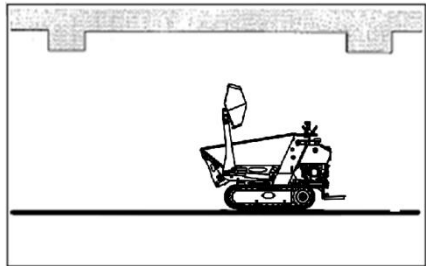

When operating under bridges, in tunnels, near cables, or indoors, be careful not to hit objects with the front shovel.



Please pay attention to flying objects

This machine is not equipped with protective equipment to protect the operator from flying objects. Do not use this machine in hazardous areas where the operator may be hit by flying objects.

Precautions during traction

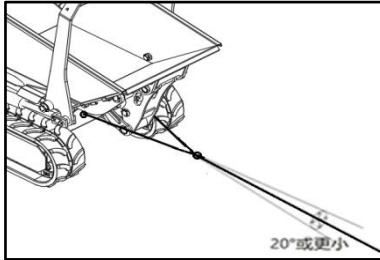

Improper operation, use of incorrect cables, or improper inspection during towing can lead to serious injury or death.

Danger can occur if the cable breaks or splits.

Use a wire rope that matches the traction force.

Do not use twisted, twisted, or even damaged cables.

Do not suddenly apply heavy loads on the cable.

When handling cables, please wear safety gloves.

Ensure that there is one operator on each machine being towed and one operator on each machine being towed.

Do not tow on slopes.

Please do not approach the cable when towing.

Please refer to the "Traction" section for more usage instructions.

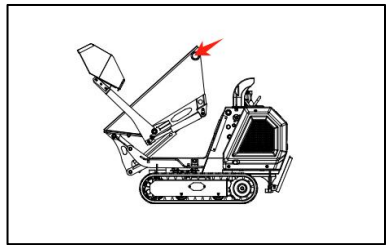

When manipulating the dumping action, please pay attention to the angle display in both horizontal and vertical directions, and do not exceed the specified upper limit of the dumping angle.

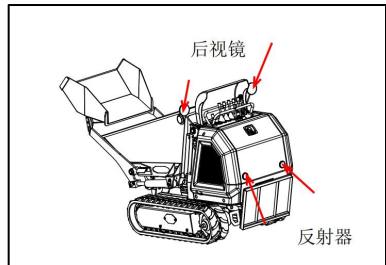

When controlling the walking motion, please note that the rearview mirror shown in the above picture can observe the situation behind the vehicle to ensure driving safety.

The installation of the rearview mirror meets the Class C field of view in the standard ISO14401-2009.

The installation of reflectors meets the requirements of ISO12509-2004

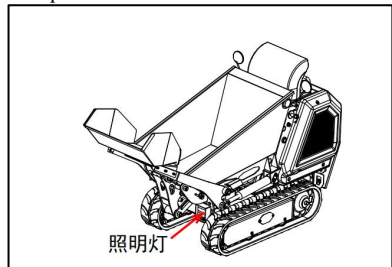

The front left lower part of the front frame of the vehicle's lighting can be turned on for operation at night or in poor lighting conditions.



Precautions when stopping

Safe parking

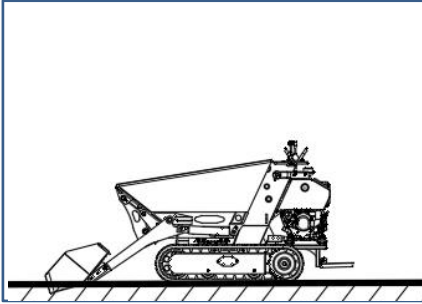

- Park the machine on a flat, solid, and safe ground, and place the front shovel on the ground.

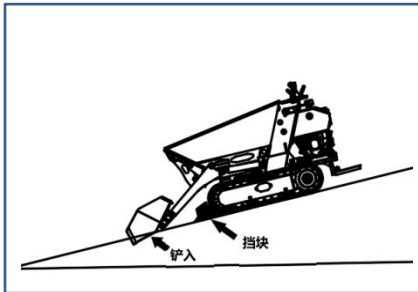

- If parking on a slope is necessary, the machine must be firmly parked and prevented from moving.
- When parking on the street, use grilles, warning signs, lights, etc. to make the machine easy to see even at night and avoid collisions with other vehicles.

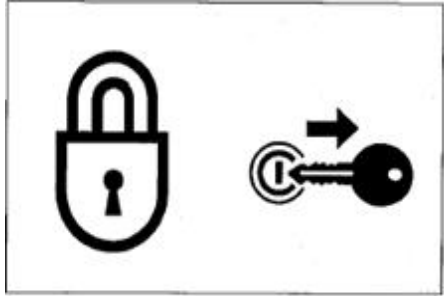

- Before leaving the machine, do the following:
 - 1. Lower the bucket and bulldozer to the ground.
 - 2. Turn off the engine, remove the starting key and take it away.
 - 3. Turn off the power switch.



Precautions during transportation

Safe loading/unloading of machines

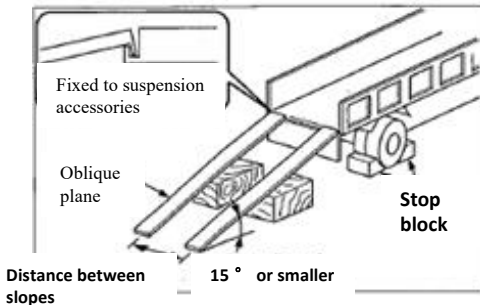

During loading and unloading, the machine may overturn or fall. Please take the following safety measures:

Choose a solid and level ground and maintain sufficient distance from the road shoulder. Secure a slope with sufficient strength and size to the truck carriage. The slope of the slope shall not exceed 15 ° . If the slope bends down too much, use props or blocks to support it.

Do not use working devices to load or unload the machine. Doing so may cause the machine to overturn or fall.

Keep the truck carriage clean and free of oil, sand, ice, snow, and other foreign objects on the loading slope to prevent the machine from slipping sideways. Clean the track.

Block the transport vehicle's tracks with wedges to prevent movement.

When loading and unloading the machine, please follow the signal from the signalman and walk slowly.

Do not change the route on the slope. Do not turn on a slope. The machine may tip over. When turning on the truck carriage, the footing may not be stable enough, so it should be done slowly.

Use a wedge to secure the track, and then use a cable or chain to secure the machine to the truck carriage.

Safe lifting machine

- Master and apply the correct lifting gestures.
- Check the lifting equipment every day to see if any parts are damaged or missing, and replace them if necessary.
- When lifting, please use a cable that can lift the weight of the machine.
- Lift the machine according to the following procedure. Do not operate in any other way, as it may cause the machine to become unbalanced.
- Please refer to the section on "Hoisting Machines" for more usage instructions.
- Do not lift when there are operators on the machine.
- When lifting, please proceed slowly to prevent the machine from overturning.
- Keep all personnel away from the work area during lifting. Do not move the machine above the top of the head.

Safe transportation machine

- When transporting machines, it is important to understand and comply with applicable safety regulations, vehicle codes, and traffic rules.
- To choose the best transportation route, consider the length, width, height, and weight of the truck after loading the machine.
- Do not suddenly start or stop or drive at high speed during transportation. Otherwise, it may cause the loaded machine to move or lose balance.



Precautions for Maintenance

Warning Information of “No Operation”

Sign

During the checking or maintenance of machine, the start of engine or the touch of any joystick by non-authorized personnel will probably result in serious injury accidents.

Before maintenance, please stop the engine and withdraw and carry the key.



Affix warning information “No Operation” to an eye-catching place such as starter switch and joystick.

Use of Correct Tools



Do not use any damaged or deteriorated tool or any tool designed for other application. Use tools suitable for related operations.

Periodically Replaced Critical Safety Parts

Replace the fuel hoses periodically. The fuel hoses will wear gradually along with time, even if no wear symptom is visible.

Upon detection of any wear symptom, replace the fuel hose, regardless of the replacement schedule.

To understand more details, please refer to the section “List of Critical Safety Parts”.

Explosion-Proof Lamps



While checking the fuel, lubricating oil, coolant, and battery electrolyte, please use explosion-proof lamps to prevent fire and explosion. Otherwise, it will probably result in explosion to cause serious injury accidents.



No Access of Non-Authorized Personnel



During operations, the non-authorized personnel are prohibited to access the working zone. Take cautions during grinding, welding, and use of hammer. You will probably be injured by the flying fragments from the machine.

Preparations of Working Zone

Select a stable and level working zone. Ensure the appropriate illumination conditions. For indoor operations, keep well ventilated. Remove obstacles and dangerous goods. Clear slippery areas.

Always Keeping Clean Machine



Please clean the machine before maintenance. Stop the engine before cleaning the machine. Cover the electric parts against water ingress. The water ingress into the electric parts will probably result in short-circuit or malfunction. Do not clean the battery, electronic control units, sensors, connector, or cab by water or steam.

Stop of Engine before Maintenance

While the machine is working or the machine is not working but the engine is running, avoid lubricating or further adjusting the machine.

If the maintenance requires the running of engine, assign two operators for teamwork and keep contact with each other.

One operator must sit in the driver seat to get ready to stop the engine immediately when necessary. This operator must pay special attention not to touch any joystick or pedal, unless it's absolutely necessary.

The other operator for the maintenance must keep the body and clothing away from motion parts of machine.



Keeping Away from Motion Parts



- Keep away from all rotating and motion parts. The entanglement of hands or tools into rotating or moving parts will probably cause accidents of serious injuries or even deaths.

Secure Fixing of Machine and Possibly Falling Parts



Before the maintenance or repairs beneath the machine, lower all movable working devices onto the ground or lowest position and fix the tracks. If it's necessary to operate beneath the lifted machine or device, always fix by cushion woods, jack, or other firm and stable supports. Do not access the area beneath the machine or working device before it's firmly supported. This operation is especially important for the hydraulic cylinder operations.

Fixing of Working Device

During the repairs and replacements of bucket teeth or side teeth, to prevent the accidental movement of machine, securely fix the working device.

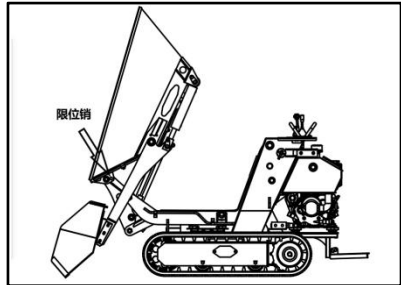

When opening the tipping bucket for maintenance, please follow the following steps:

1. Lower the lifting device to the stop.
2. Flip the bucket to the stop and insert the limit pin.
3. Lower the front shovel to the bottom or stop.

Place the heavy object in a stable position



When it is necessary to temporarily place heavy objects or accessories on the ground during disassembly or installation, be sure to place them in a stable place. Do not allow unauthorized personnel to approach places where such items are stored. weights or attachments onto the ground during disassembling or installation, please ensure to place them in a steady place. Keep the non-authorized personnel away from the place for storage of such objects.



Precautions for Refueling



The smoking and open fire are prohibited during refueling and near the refueling point. Do not disassemble the fuel tank cap or refuel while the engine is running or is not cooled down. Do not splash fuel to any high temperature surface of machine.

Refuel the fuel tank in a well-ventilated place. Do not top up the fuel tank. Leave an expansion

space for the fuel.

Any overflowed fuel shall be wiped away immediately.

Tighten the fuel tank cap securely. If the fuel tank cap is missing, replace with original cap only. The use of non-authorized fuel tank cap with poor ventilation will cause internal

pressure in the fuel tank.

Do not use fuel for any cleaning purpose. Use correct fuel grade based on the season.

Handling of Hoses

The leakage of lubricating oil or fuel can result in fire accident.

Do not distort, bend, or impact any hose.

Do not use any distorted, bent, or cracked pipeline, metal pipe, or hose, otherwise it will probably result in burst.

Re-tighten any loose connector.

Be careful when operating high-temperature and high-pressure components



- Please stop the engine and wait for the machine to cool down before maintenance.
- The engine, exhaust pipe, radiator, hydraulic pipes, sliding parts, and many other machine parts are really hot when the engine is just stopped. Touching such parts can cause scalding.
- The engine coolant, hydraulic oil, and other fluids are also under high temperature and high pressure status.

Take cautions not to touch the hydraulic oil while loosening engine hood or connector. Operating the machine under such condition will cause out-spray of hot oil to result in scalding or injuries.

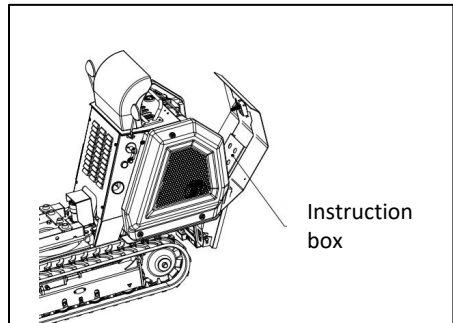

The manual of this vehicle model is stored in the manual box on the inner side of the rear door, as shown in the above picture



Caution against Internal Oil Pressure

Take caution against internal oil pressure.

After the stop of engine, the pressure in the hydraulic oil pipes can hold for a long time.

Before the maintenance, thoroughly relieve the internal pressure.



The high pressure of hydraulic oil can penetrate skin and eyes to cause serious injuries and blindness or even death. Please bear in mind that the hydraulic oil permeating from orifices is nearly invisible to naked eyes. While checking for leakage, wear goggles and thick gloves and protect the skin by paper boards or plywood to protect against the harms of spraying hydraulic oil.

The hydraulic oil penetrating into your skin must be cleared by a doctor familiar with such injuries with surgical method within several hours.

Before working on the hydraulic system, the pressure should be relieved first

Before the hydraulic system releases pressure, if the cover or filter is removed or the pipeline is disconnected, hydraulic oil may spray out.

- Slowly loosen the exhaust plug to release the fuel tank pressure.
- When removing the plug or screw or disconnecting the hose, stand on one side and slowly release it to gradually release the internal pressure before removing it.
- Oil or oil plugs may spray out due to pressure in the walking motor oil tank. Please slowly loosen the oil plug to release internal pressure.

Be careful of flying debris when using a hammer

When using a hammer, pins or metal debris may splatter everywhere. This may cause serious injury.

- When striking hard metal parts such as pins and bearings with a hammer, please wear protective equipment such as goggles and gloves.
- When striking the pin, please ensure that there is no one around.



Be careful of high-pressure grease



In the track tensioning device, this model adopts a mechanical adjustment type. Please follow the specified procedure below when adjusting.

- Loosen the fixing nut of the adjustment screw.
- Slowly turn the adjustment screw with a wrench. If you need to tighten the track, please adjust it clockwise, and vice versa.
- Check and verify the tightness of the track.
- After the tightness of the track is appropriate, tighten the fixing nut of the adjustment screw.

If there is a malfunction. Please contact Digger King service agent for repair.

Do not disassemble the track tensioning device

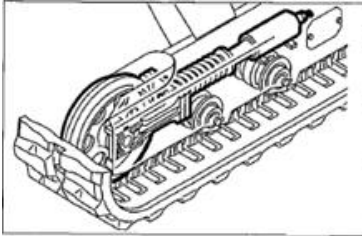

The track tensioning device is equipped with a strong spring. When the tensioning device of the cover belt is accidentally removed, the spring will pop out, resulting in serious injury. Do not disassemble the belt tensioning device.

Disconnect the battery cable



Before performing electronic system operations or welding, please disconnect the battery cable. First, disconnect the negative (-) battery cable. When reconnecting, finally connect the negative (-) battery cable.

Please be careful when handling batteries

- The battery contains sulfuric acid, which can damage the eyes or skin if accidentally touched.
 - If accidentally enters the eyes, rinse immediately with water and seek medical attention promptly.
 - If swallowed accidentally, drink plenty of water or milk and seek medical attention immediately.
 - If sulfuric acid comes into contact with skin or clothing, it should be immediately washed off with plenty of water.
- When operating the battery, goggles and gloves should be worn.
- Batteries can generate flammable hydrogen gas, which may cause explosions. Stay away from open flames, sparks, or lit cigarettes and other sources of ignition.
- When checking the electrolyte level, use a flashlight.
- Before checking or handling the battery, make sure to turn off the start switch to turn off the engine.
- Please be careful not to let metal tools or any metal objects come into contact with the electrodes and cause a short circuit.
- When the electrodes are loose, electric sparks will be generated. Be sure to tighten it.



- Ensure that the battery cap is securely closed.
- When the battery freezes, do not charge or jump start the engine; Otherwise, an explosion may occur. Heat the frozen battery to 15C before use.
- Do not use batteries when the liquid level is below the lower limit. Otherwise, it will accelerate the internal aging of the battery and shorten its lifespan. It can also cause rupture (explosion).
- Do not add distilled water above the upper limit. Otherwise, it may cause electrolyte leakage. Contact with this liquid can damage the skin or corrode machine components.
- Clean the area around the electrolyte level line with a damp cloth and check the level.
- Do not use a dry cloth for cleaning; Otherwise, it can lead to static electricity accumulation, combustion or explosion.

Regularly replace safety critical components

- To ensure safe use of the machine for a longer period of time, regular refueling and inspection and maintenance should be carried out. To improve safety, please regularly replace safety critical components such as hoses and seat belts. For more details, please refer to the "Regularly Replacing Safety Critical Components" section.
- "Regularly replaced safety critical components" refer to components that have aged, worn, and degraded in function after repeated use, and the performance of such components may change over time. The characteristics possessed by such components can cause serious mechanical damage or personal injury, and it is difficult to determine their remaining service life solely based on visual inspection or operating experience.
- If any damage is found during visual inspection, please replace the "regularly replaced safety critical components", even if the specified replacement interval has not been reached.

Using a battery charging cable to jump start

- When using the battery charging cable to start the engine, be sure to follow the correct steps below to connect the cable. Incorrect cable connection can cause discharge and battery explosion.
 - Don't let the "problem machine" and "rescue machine" collide with each other.
 - Do not touch or contact the positive (+) and negative (-) clamps of the battery charging cable with the machine.
 - When connecting, first connect the positive pole of the battery charging cable to the positive (+) terminal. When disconnecting, first disconnect the negative cable from the negative (-) terminal (ground terminal).
 - Please make sure to firmly connect the cable clamp.
 - Connect the last clip of the battery charging cable as far away from the battery as possible.
- When starting the engine with a battery charging cable, always wear protective goggles and gloves.
- Use battery charging cables and clamps that are suitable for the battery capacity. Do not use damaged or corroded battery charging cables and clamps.
- Ensure that the battery capacity of the "rescue machine" is the same as that of the "problem machine"



Please entrust a Digger King service agent to carry out welding repair

When welding operations must be carried out, qualified personnel must be present in a fully equipped workplace. To prevent damage to any components of the machine caused by excessive current or electric sparks, please follow the following instructions.

- Before welding, the battery wiring should be disconnected.
- Do not continuously apply voltage of 200V or greater.
- The grounding point must be connected within a range of 1 meter from the welding site. Do not connect the ground terminal near the electronic control device/instrument or connector.
- Ensure that there are no sealing rings or bearings between the welding area and the grounding end.
- Do not connect the ground terminal around the pin or hydraulic cylinder of the working device.
- When welding the machine body, the connector of the electrical control device should be disconnected before the operation.

Vibration borne by the operator

The test results on the vibration transmitted by the machine to the operator show that the vibration borne by the operator's upper limbs is less than 2.5 m/s², while in the seat area, the vibration borne by the body is less than 0.5 m/s².

Inspection after maintenance

- Slowly increase the engine speed from low idle to maximum speed and check for any oil or water leakage from the repair parts.
- Operate each control lever and check if the machine is operating normally.

Waste disposal



- Ensure that the waste oil discharged from the machine is collected in a container. Improper disposal of waste oil can cause harm to the environment.
- When handling harmful objects such as lubricants, fuel, coolant, solvents, filters, and batteries, please comply with applicable laws and regulations.

Handling of Hazardous Chemicals

Direct contact with harmful chemicals can cause serious harm. The harmful chemicals used in this machine include grease, battery electrolyte, coolant, coatings, and adhesives.

Please handle hazardous chemicals carefully and properly.



Safety Signs

To guarantee the safety of operator and operation personnel in the working zone, please set up the following safety signs (markings) at some portions of machine. Walk around the machine with this manual and observe the contents and placement locations of these safety signs. Please review these signs and operation instructions contained in this manual jointly with the machine driver.

- The safety signs shall be clean, clear, and easily legible. If any safety label falls, is damaged, or becomes illegible, please replace with new one. Please provide your product serial number while ordering new signs from a Digger King service dealer.
- If a part/body on which a safety sign is affixed is already replaced, affix a new sign to new part/body.



Safety
Safety Signs

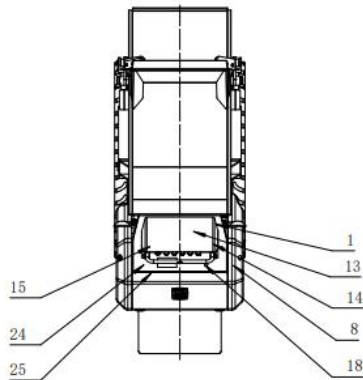
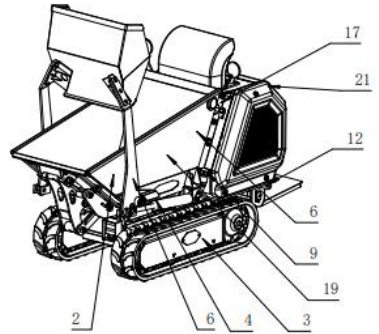
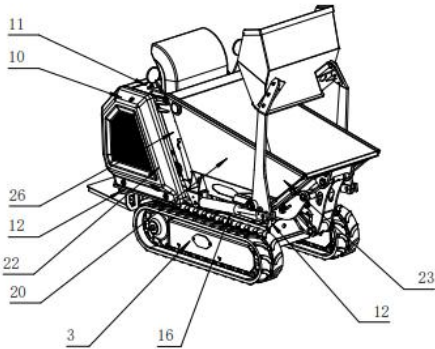



1. Warning

Carefully read and understand the manual before operations, checking, and repairs of machine.



2. Safe distance.

Never approach to or stand in the working zone of machine.



3. Danger from underbody bolts thrown from track roller adjuster. To guarantee the safe and correct operations, ensure to read the operation manual before adjusting the track roller adjuster.



4. Risk from rotating parts. Please turn off before checking and maintenances.



5. Safe distance and danger from collision with working device. Please keep away from machine during operations.



6. No one is allowed to stand within the scope of work





8、Warning

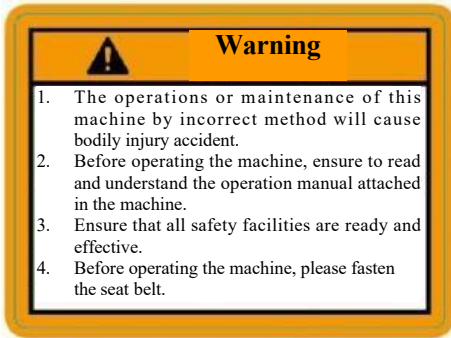

9、DIESEL



10、HYDRAULIC OIL



11、It's prohibited to touch any joystick or traveling joystick while getting on or off the machine, otherwise the parts will be damaged.



12、Direction of improvement



13、Tipping bucket operation indicator

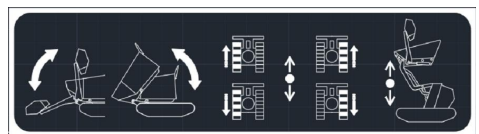



14、Throttle identification



18、Start identification

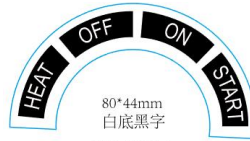

15、High and low speed identification

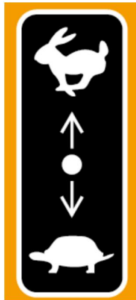

22、Stay away from high temperature signs



16、Battery identification



17、Main power switch identification





23、 Stay away from signs while working



24、 Hearing protection signs



25、 Ear side noise identification

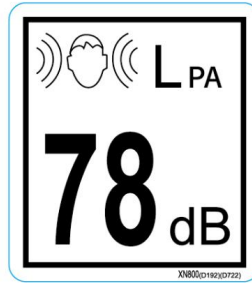

26、 External noise identification

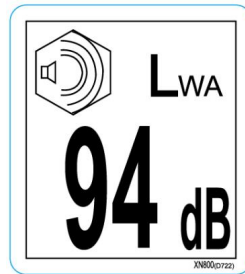

Control



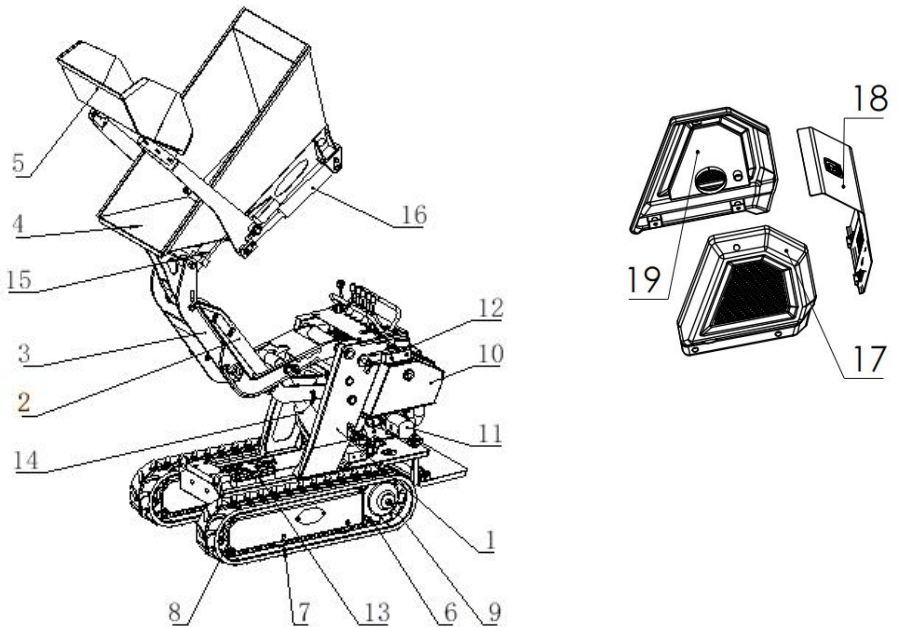

Serial Number	Name	Serial Number	Name
1	Frame	9	Traveling motor
2	Lifting link	10	Hydraulic tank
3	Lifting arm	11	Main pump
4	Tipping bucket	12	Engine
5	Front shovel	13	Storage battery
6	Eriving wheel	14	Lifting cylinder
7	Thrust wheel	15	Tipping bucket oil cylinder
8	Guide wheel	16	Front shovel oil cylinder
17	Left side surround	18	Back cover
19	Right side surround		

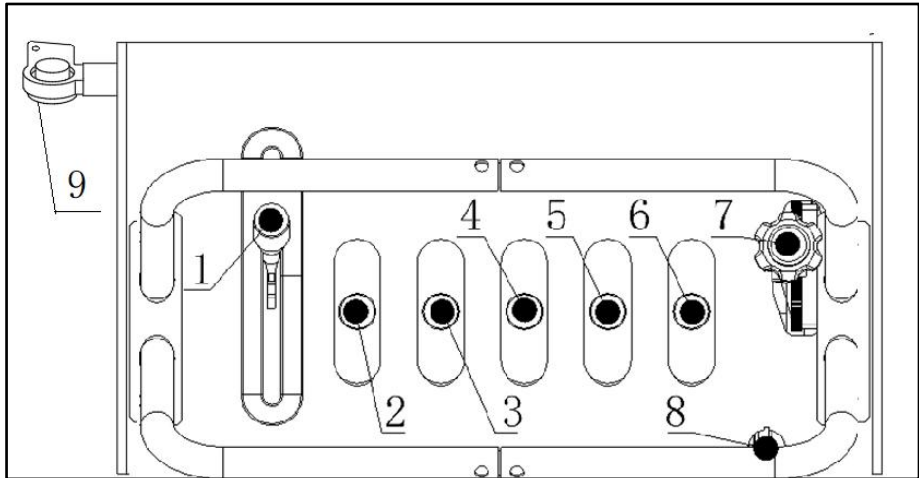

1. High and low speed control lever
2. Front shovel control lever
3. Tipping control lever
4. Left travel control lever
5. Right travel control lever
6. Lifting device control lever
7. Manual throttle
8. Start switch
9. Power switch

If there are differences, it depends on the overall machine parameters or the selected product.



Start Key



The start key is used to start the engine.

Maintenance cover



Caution

Before opening the access panel, ensure that the safety lock handle is at locking position and the engine is stopped.

When opening or closing the service cover, please be careful not to pinch your hands or other parts of your body.

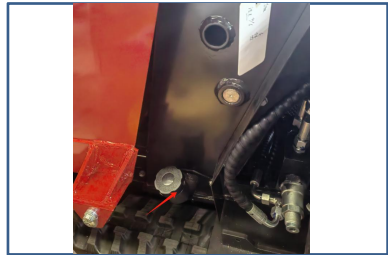

Opening

1. Insert the hood key and turn it counterclockwise to unlock the maintenance cover.

Closing

1. Close the maintenance cover.
2. Insert the key and turn it clockwise to lock the maintenance cover.



Switch

start switch

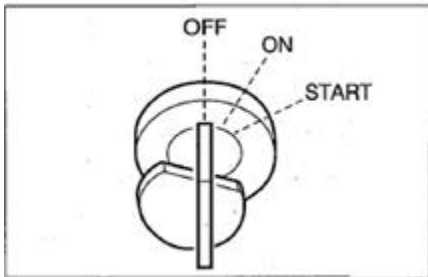

Important: Do not repeatedly turn the starting key from OFF to ON and then from ON to OFF in a short period of time, otherwise it may cause engine failure.

OFF... This position is used for engine shutdown, insertion and extraction

Move the key.

ON... engine running position. At this location, all

All electrical devices are running.

START... engine running position, when releasing the key, the switch

Automatically return to the ON position.

Power switch

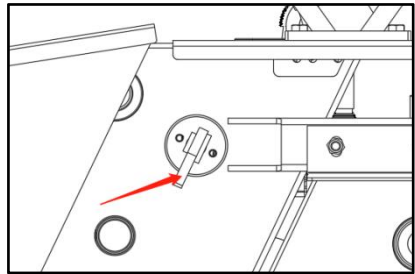

Action:

Insert the handle and turn it right to the limit position to connect the power supply.

Turn the left handle off the limit and disconnect the power supply.



Throttle control lever

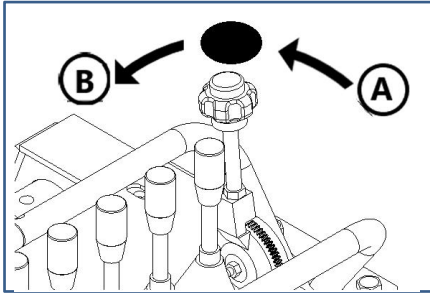

Used to control engine speed.

(A) ... low idle

(B) ... maximum speed

controller



Warning

Attention: Please understand and familiarize yourself with the functions of all control levers before operation

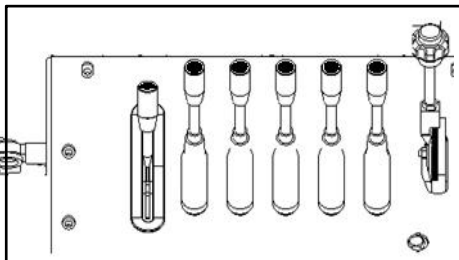

Operatation





Before Start of Operations Getting on/off Machine



Warning

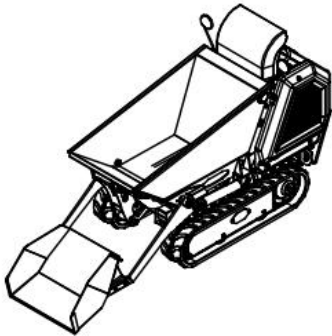

- Do not jump on or off the machine.
- When stepping on the pedals, hold onto the armrest to support your own weight, keeping your body in a balanced position (hands and feet).
- Do not use the control lever as an armrest.

Bypass inspection

Before starting the engine for the first time on that day, perform a daily detour inspection.

Please refer to "Maintenance, Bypass Inspection" in Part 5 for details.

Daily routine inspection

Before starting the engine for the first time on that day, perform a daily detour inspection.

Please refer to Part 5 "Maintenance, Daily Routine Inspection" for details.



Starting and stopping the engine

Before starting the engine

1. Check and confirm that the surrounding environment of the machine is safe and controllable.

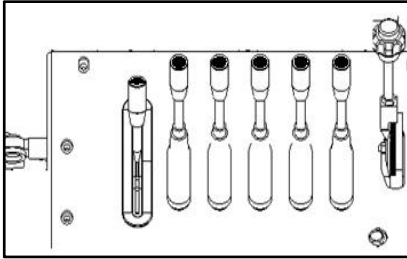

2. Check and confirm that all control levers are in the neutral position.

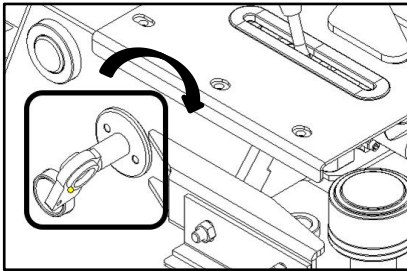

3. Turn the power switch handle to connect the power supply.

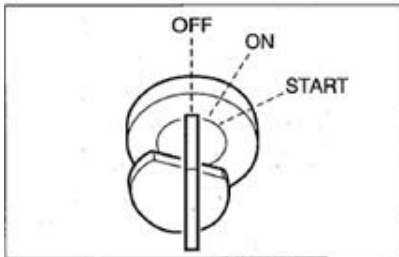

4. Insert the key into the start switch and rotate it to the ON position.

Start of Engine

warning

Toxic gas hazard, engine exhaust contains carbon monoxide, which can kill you within a few minutes. Although you haven't smelled the smell of exhaust gas, you may still be exposed to hazardous carbon gas. If you feel nauseous, dizzy, or weak while using this product, please breathe fresh air immediately. You may be poisoned by carbon monoxide.

·Carbon monoxide gas may accumulate in the occupied space. To reduce the risk of carbon monoxide gas, please only operate this product outdoors and away from windows, doors, and ventilation openings.

According to the manufacturer's instructions, install a battery operated carbon monoxide alarm or a plug-in carbon monoxide alarm with a backup battery.

The smoke alarm is unable to sense carbon monoxide gas.

·Do not operate this product in homes, garages, basements, crawling spaces, sheds, or other enclosed spaces, even if you use fans or open doors and windows for ventilation. After the product runs, carbon monoxide will quickly accumulate in these spaces and stay for several hours.

Always place this product downwind and point the engine exhaust away from the occupied space.

warning

Fuel and its vapor are flammable and explosive. Fire or explosion may cause burns or death: When starting the engine, make sure that the spark plugs, muffler, fuel cap, and air filter (if equipped) are installed correctly., Do not start the engine with the spark plug removed.

If the engine is full of water, set the choke (if equipped) to the open or run position. Move the throttle (if equipped) to the fast position and crank until the engine starts. If there is a natural gas or low-pressure gas leak in the area, please do not start the engine· Do not use pressurized starting fluid because steam is flammable.



Start of Engine



Warning

- Clear all personnel from the work area.
-

Important: Do not run the starting motor continuously for more than 15 seconds. If the engine fails to start, please wait for 60 seconds and then try starting the engine again.

Important: If the engine stalls due to fuel shortage, please add fuel. Starting the motor for a long time before sufficient fuel enters will cause the starting motor to fail.

Important: Before injecting fuel to start the diesel engine, it is necessary to check whether there is air mixed in the oil circuit. If so, the gas should be discharged. Please refer to "Diesel Filter Replacement" in Part 6.

Before starting the engine, disconnect or remove all external devices and engine loads. Ensure that directly connected equipment components, such as but not limited to blades, impellers, pulleys, and sprockets, are correctly connected. 1. Check the engine oil. Please refer to the section on checking the oil level. 2. Ensure that the device drive control device (if equipped) is disconnected. 3. Push the stop switch (if installed) to the ON position. 4. Move the throttle control device (if installed) to the fast position. Operate the engine in a fast position. 5. Move the damper controller to the damper position. **Attention:** When starting and warming up the engine, it is usually not necessary to use a choke. If installed, move the fuel shut-off valve to the open position. 7. Rewind start, if installed: Grasp the power cord handle tightly. Slowly pull the starter power cord handle until resistance is felt, then quickly pull. 8. Electric starting, if installed: Turn the electric starting switch to the ON or Start position. 9. When the engine warms up, move the choke control to the RUN position.



Starting operation

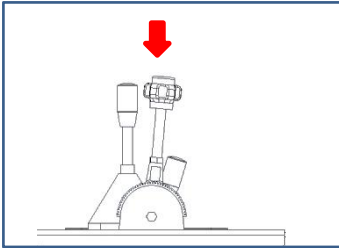

1. Pull the throttle control lever to the middle position.

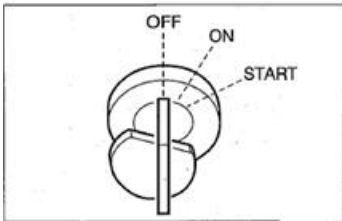

2. Turn the start key to the START position to start the engine.
3. Release the key immediately after the engine starts.
4. The key automatically returns to the ON position.
5. If the diesel engine cannot start after running the starting motor for 10 seconds, please wait for 15 seconds before starting again. (Long term operation of the starting motor can lead to the consumption of battery power and may also burn out the motor.)

Turn off the engine

Important: Do not suddenly turn off the engine when operating under heavy loads or at high speeds. Doing so may cause the engine to overheat or get stuck. Do not stop the engine unless in an emergency.

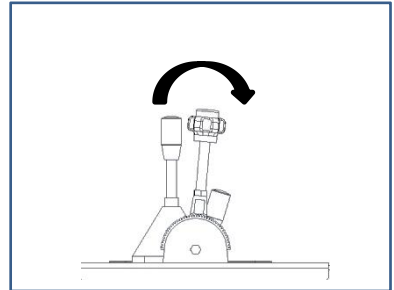

1. Return to the throttle control lever.
2. Allow the engine to idle for approximately 5 minutes.
3. Turn the start key to the OFF position and turn the engine off.

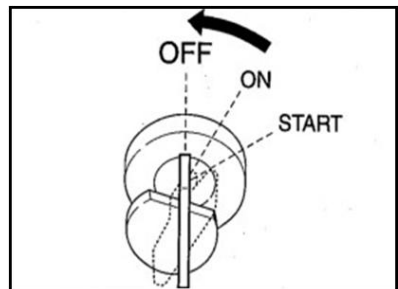



Operations of Machine

Warning

Operation diagram

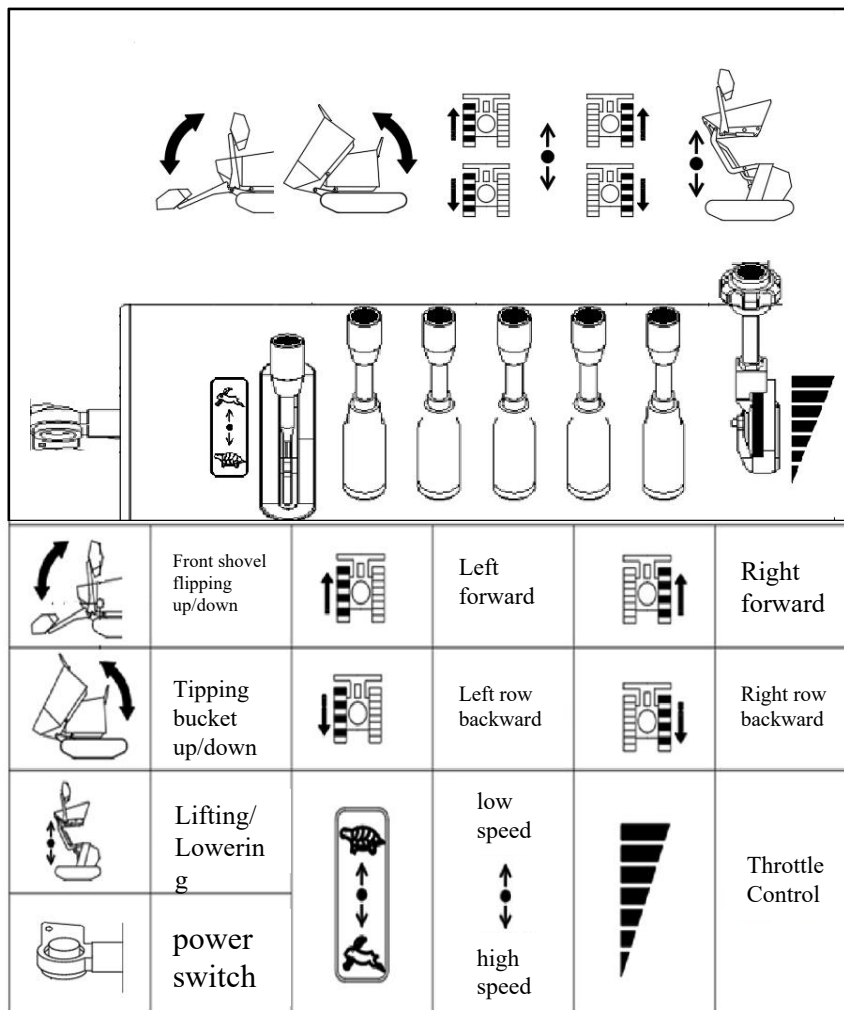



Operate the walking control lever



Warning

Do not allow anyone to enter the working range and path of the machine.

There is a blind spot in the rear of the machine. Before walking backwards, if necessary, check the safety behind and confirm that there is no one behind.

Clear all obstacles in the machine path.

1. Pull the throttle control lever to increase the engine speed.

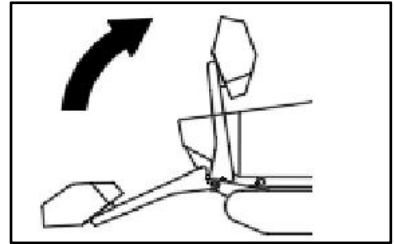

2. Stow the front shovel operation device.
3. Operate the travel control lever as follows.

Moving the machine forward and backward

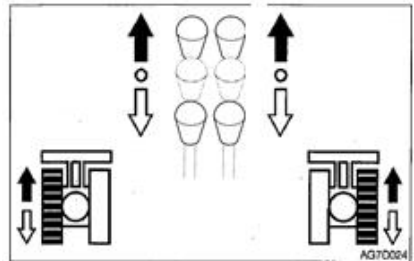
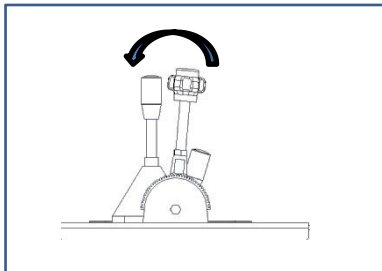

During operation:

To move forward:

Then pull the travel control lever

forward. To walk backwards:

Then pull the walking control lever
backwards.



Pivot rotation

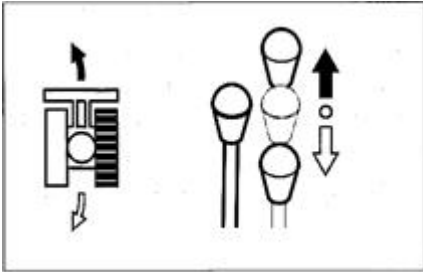

Turn left during shutdown:

To make a left turn ahead: Pull the right joystick forward. To turn left from behind: Pull the right joystick back.

When turning backwards, operate the left joystick in the same way as the right joystick.

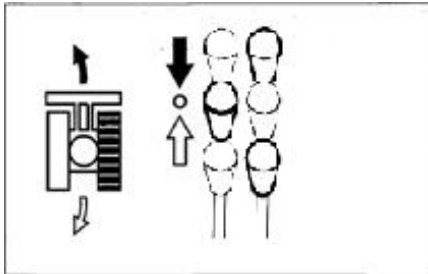

Turn left while walking:

Turn left when walking forward:

Place the left joystick in the center position.

Turn left when walking backwards:

Place the left joystick in the center position.

To turn right while walking, use the same method as operating the left joystick to operate the right joystick.

Go Round

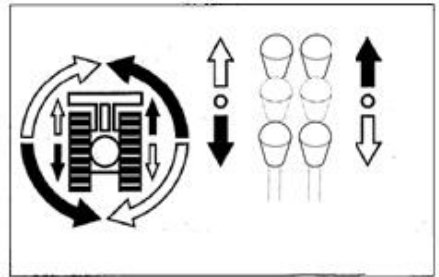

Turn left in place:

Pull the left joystick backward and the right joystick forward.

Turn right in place:

Pull the right joystick backward and the left joystick forward.

Switching between high and low speed walking

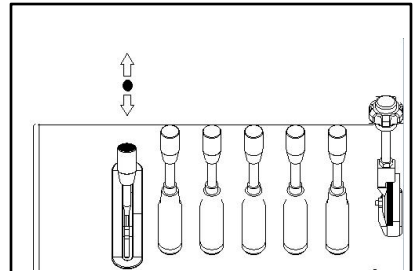

Switching to high-speed walking:

Pull the high and low speed control lever forward.

Switching to low speed walking:

Pull the high and low speed control lever backward.



Parking



Warning

- Park the machine on a flat, solid, and safe ground. Set the parking device. If it is necessary to park on a slope, wedges should be used to block the tracks to prevent the machine from moving.



Caution

Do not stop the machine unless in an emergency.
Try to park at the best possible time.

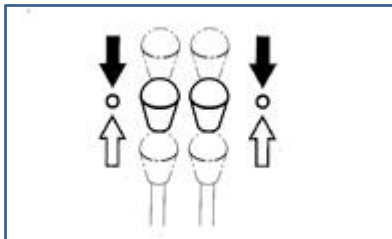

Slowly place the left and right travel control levers in the center position, and the machine stops.



Operating the working device

Warning

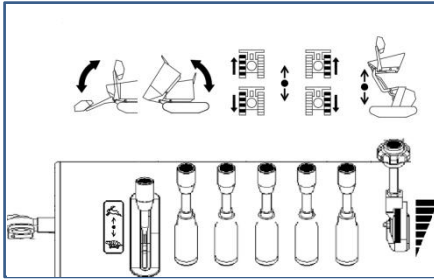

Operating the front shovel

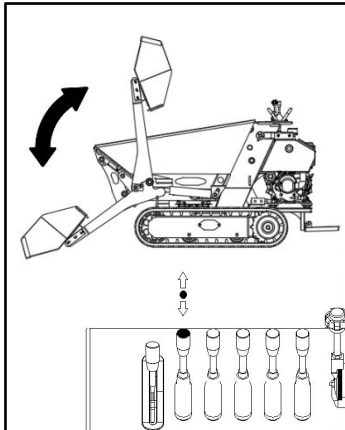

- Front shovel flipping up: Pull the front shovel control lever backwards.
- Lowering the front shovel: Pull the front shovel control lever forward.

Operating the tipping bucket

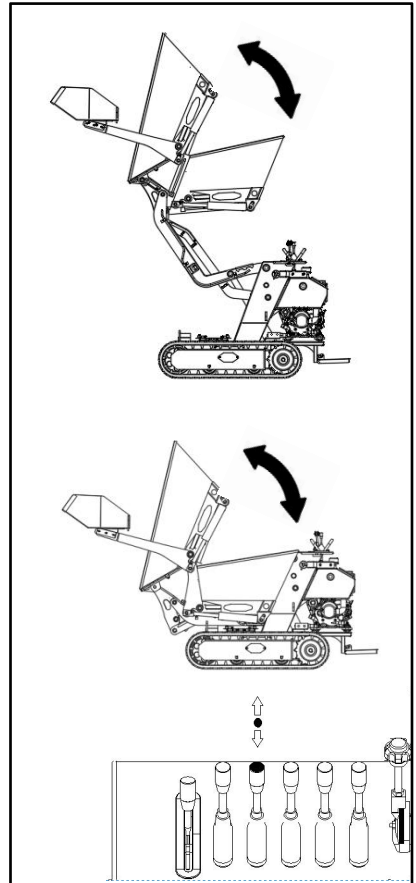

- Tipping bucket unloading: Pull the tipping bucket control lever backwards.
- Flip bucket return: Pull the flip bucket lever forward.
- Please ensure that the front shovel is in the position shown when unloading the tipping bucket



Operating the lifting device

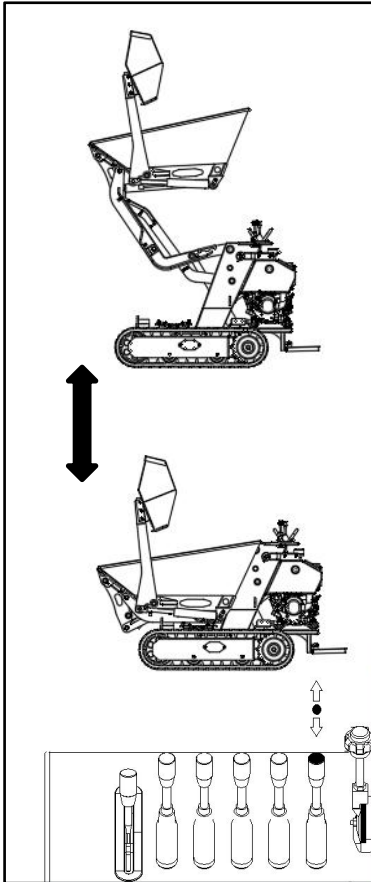

- Lifting: Pull the lifting lever forward.
- Lowering: Pull the lifting lever backwards.



Precautions for operation

Precautions when walking

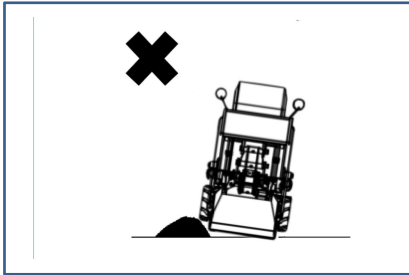

Walking on obstacles (rocks, tree stumps, etc.) may impose a significant load on the body and may cause damage to it. Try to avoid crossing obstacles as much as possible. If this is necessary, walk at low speed to allow the center of the track shoe to cross the obstacle.

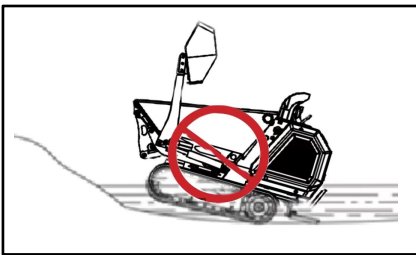

The rear of the machine must not be submerged in water.

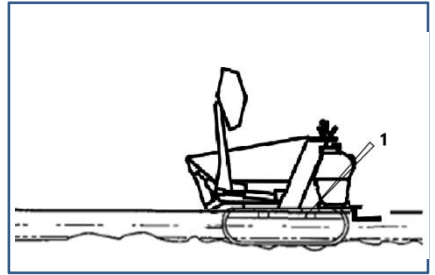

- Allowable water depth
- Only when underwater does not exceed the middle of the track shoe (1)
- Only in water can this machine be used.
- For parts that have been used in water for a long time, sufficient grease should be added until the old grease is squeezed out.
- Do not immerse the main body in water or sand. If submerged, please contact a Digger King service agent for inspection.



Precautions for driving on slopes



Warning

- Do not walk on steep slopes where the machine cannot maintain its stability. Please note that in practical use, the performance of the machine on slopes may decrease due to its harsh operating conditions.
- When walking on slopes or ramps, drive slowly at a low speed. In an emergency, lower the bucket to the ground and turn off the machine.
- When climbing a mountain, keep the driver's seat facing the hill. When going downhill, keep the driver's seat facing the downhill direction. In both cases, it is necessary to pay attention to the ground in front of the machine when walking.

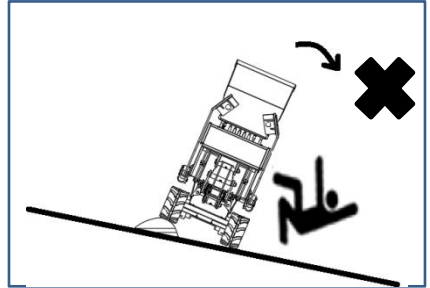

- Do not change direction on slopes or cross slopes. First, return to the flat ground, and then choose another path.
- When walking on gentle slopes covered with grass or dead leaves, or on wet metal plates or frozen surfaces, the machine may slip sideways. Do not park the machine horizontally on a slope.



The operations that can be performed on this machine

freight

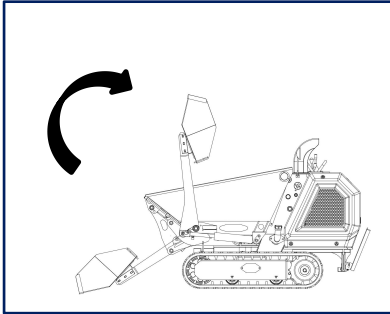

unload

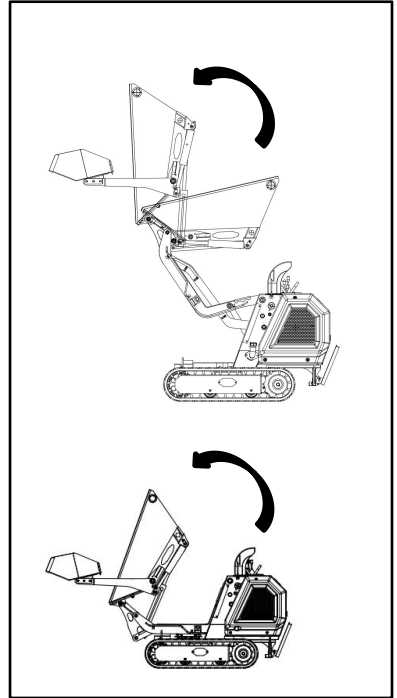

transport

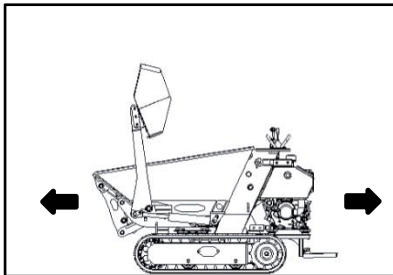



Stop the machine

Parking



Warning

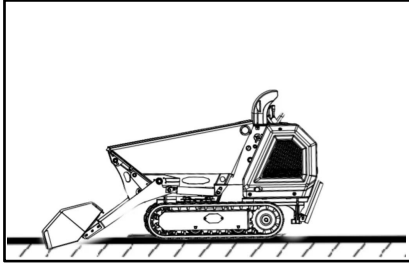

- Park the machine on a flat, solid, and safe ground and lower the front shovel to the ground.

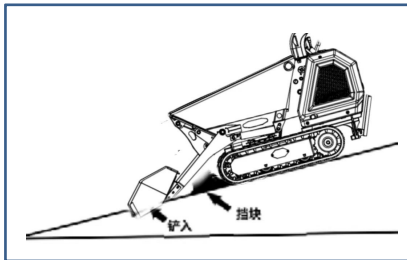

- If it is necessary to park or tilt the machine on a slope, firmly park the machine and prevent it from moving.
- When the machine is on the street, use grilles, warning signs, lights, etc. to make it easy to see even at night and avoid collisions with other vehicles.

- Before leaving the driving position, turn off the engine and turn off the power switch. At the same time, please be sure to remove the key and carry it with you, then store it in a designated place.

1. Place the left and right travel control levers in the center position.
2. Pull the throttle control lever backwards to idle the engine and lower the front shovel to the ground.
3. Turn off the engine, remove the key, and turn off the power switch.
4. Please refer to "Engine Off" in Part Three for details

Check after turning off the engine

1. Check for oil or water leaks, check the working device, cover, and lower frame. If any abnormal conditions are found, please repair them.
2. Top up with fuel.
3. Remove the soil from the lower frame.



Warning

Lock and be sure to remove the key when leaving.

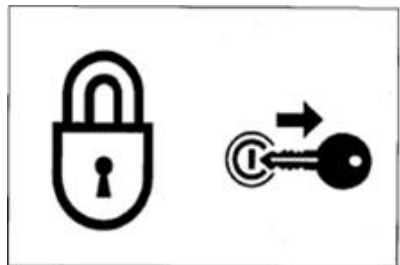



Handling in cold climates

Preparation for Cold Climate

It is not easy to start the engine in cold weather conditions.

Replace fuel and lubricants

Change hydraulic oil, engine oil, and fuel to models suitable for cold climates.

Please refer to the "Fuel and Lubricant Tables" in Part 5 for details.

Battery

When the temperature decreases, the battery performance decreases.

Check the battery. If the battery is discharged, please contact a Digger King service agent for charging.

Please refer to "Checking the Battery Level and Replenishing" in Part 5 for details.

Precautions after operation

Please follow the following precautions to prevent the machine from being unable to move due to soil, water, or freezing of the lower frame.

- Remove all mud and water from the body.
Especially clean the hydraulic cylinder rod to prevent damage to the seal caused by soil or dust on the rod surface entering the seal together with water droplets.
- Park the machine on a hard and dry ground. If this is not possible, please park the machine on a wooden floor.
- Due to a significant decrease in battery capacity in low-temperature environments, cover the battery or remove it from the machine and store it in a warm place. If the electrolyte level is low, add it before starting work in the morning
- Add distilled water. To prevent the battery electrolyte from freezing at night, do not add water after work during the day.

After a cold climate

When the climate warms, do the following:

- Replace the fuel and lubricating oil for each component according to the model specified in the "Fuel and Lubricating Oil Table".
- Please refer to the "Fuel and Lubricant Tables" in Part 5 for details



Handling rubber tracks

Due to the use of rubber tracks, they have an inherent weakness, namely a lack of strength. Please be sure to comply with the following prohibitions and precautions to prevent damage or detachment of rubber tracks.

Ban

Do not walk or operate the machine in the following locations:

- Walking on crushed stones, rough and hard rocks, steel beams, scrap iron, or near the edges of steel plates can damage rubber tracks.
- Walking on the riverbed or in areas with a large amount of pebbles may cause the stones to get stuck in the tracks and damage them or cause them to fall off.
- Do not use this machine at the seaside as salt may cause corrosion of the steel core.
- Do not allow fuel, lubricants, salt, or chemical solvents to adhere to the track. These substances may corrode the welded joints of the track steel core and cause rust or detachment. If any of these substances come into contact with the track, they should be immediately cleaned with water.
- If this machine walks on irregular surfaces, such as newly paved asphalt roads, exposed to bonfires or walking on hot iron plates under scorching sun, it will cause unconventional wear or damage to the tracks.
- Do not move the rubber track to the ground where it may slip, otherwise it may accelerate track wear.

matters needing attention

When operating this machine, please follow the following precautions:

- At any time, please try to avoid sudden changes in route or turning in place on the concrete surface. Doing so will wear or damage the rubber tracks.
- Avoid falling and causing strong impact on rubber tracks.
- Salt, Potassium chloride, ammonium sulfate, Potassium sulfate and lime heavy Superphosphate will damage the track. If any of these substances come into contact with the track, they should be thoroughly cleaned with water immediately.
- Do not let both sides of the rubber track rub against concrete or walls.
- Be particularly careful on snowy or frozen surfaces in winter, as the tracks are prone to slipping under such conditions.
- Please use rubber tracks between -25 °C and 55 °C.
- When storing rubber tracks for a long period of time (three months or longer). Please store indoors in a place that is not exposed to direct sunlight or rain.



Prevent rubber tracks from falling off

Observe the following precautions to prevent track detachment:

Always maintain appropriate tension on the track.



- When the vehicle wants to cross large steps such as pebbles or larger rocks (15 centimeters or deeper), it should climb the steps at a right angle and do not change the route on the steps.



- Please avoid walking when placing one track on a slope or protruding part while the other track is on a flat surface (when the machine is tilted at an angle of 10° or more). Please walk with both tracks on a flat surface.



- Do not change direction when the track is loose as shown in the figure.

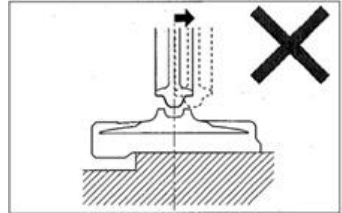

- In this case, if the machine moves backwards, the rubber tracks will come off.

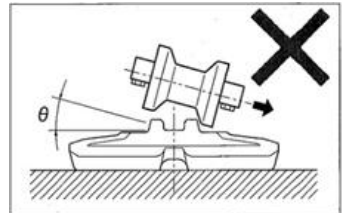

- In this case, if the machine rotates, the rubber tracks will come off.

Transportation





Loading and Unloading

Warning

The machine will probably roll over or fall off during unloading. Ensure to take the

following safety measures:

- Select a solid and level ground and keep a sufficient spacing from the road curb.
- Fix the ramps of sufficient strength and dimensions to the cargo body of truck. The inclination of the ramps shall not exceed 15°. If the ramps deflect downward excessively, please support the ramps by supports or cushion blocks.
- Do not load or unload the machine by working device. Otherwise, it will probably result in rollover or falloff of machine.
- Keep the truck cargo body and the ramps clean without oil, sand, ice/snow, or other impurity, in order to prevent the side slip of machine. Clean the tracks.
- Block the wheels of transport truck by wedges to prevent movement.
- While loading or unloading the machine, drive the machine slowly in 1st gear (low speed) as per the signals of the signaler.
- Do not change direction on ramps.
- Do not slew/swing on ramps. Otherwise the machine will probably roll over.
- Slewing/swinging the machine on the cargo body of truck will probably result in unstable legs of machine. Therefore, operate slowly.
- If possible, lock the cab doors after loading. Otherwise the cab doors will probably open during the transport.
- Plug securely the tracks by wedges and then fix the machine to the truck cargo body securely by ropes or chains.

During the loading or unloading of machine, please ensure to use ramps or platform and abide by following procedures.

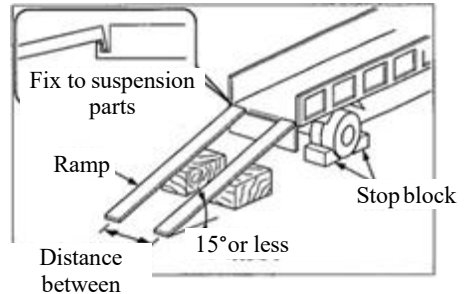

1. Securely apply the parking device of transport truck and block the wheels by wedges.
2. Place the ramps securely onto the truck cargo body. The inclination of the ramps shall not exceed 15°.
3. Align the center of truck cargo body with the center of machine and align the center of ramps with center of tracks.
4. According to the signaler's signals, drive the machine straightly up or down along the ramps in 1st gear (low speed).
5. Load the machine to designated position of transport truck. Refer to "Transport Status" in page 4-6 for details.

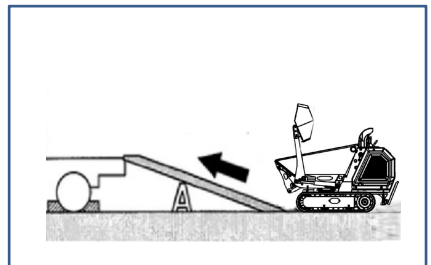



Lifting of Machine



Warning

- **Master and use the correct lifting signals.**
- **Daily check the lifting device for damaged and missing parts and when necessary replace.**
- **Please use the ropes of sufficient capacity for the machine weight during lifting.**
- **Lift the machine as per the procedure described below. Do not operate by any other method. This is really dangerous as it will probably result in imbalance of machine.**
- **Do not operate the lifting if there is any operator on the machine.**
- **Operate slowly during lifting to prevent the rollover of machine.**
- **During lifting, keep all personnel away from working zone. Do not move the machine over any person.**

Important: This lifting method is applicable for the models with standard overall parameters. The gravity center varies depending on the installed attachments and optional devices. To understand more details, please contact your Digger King service dealer.

Lifting

1. Raise the front shovel to its highest position.
2. Turn off the engine, remove the starting key, turn off the power, and leave the machine.
3. Install the cable as shown in the following figure. Install the cable and lifting accessories, taking care not to touch the machine body.
4. Slowly lift the machine until it leaves the ground.
5. Stop lifting until the machine becomes stable, and then lift the machine again.

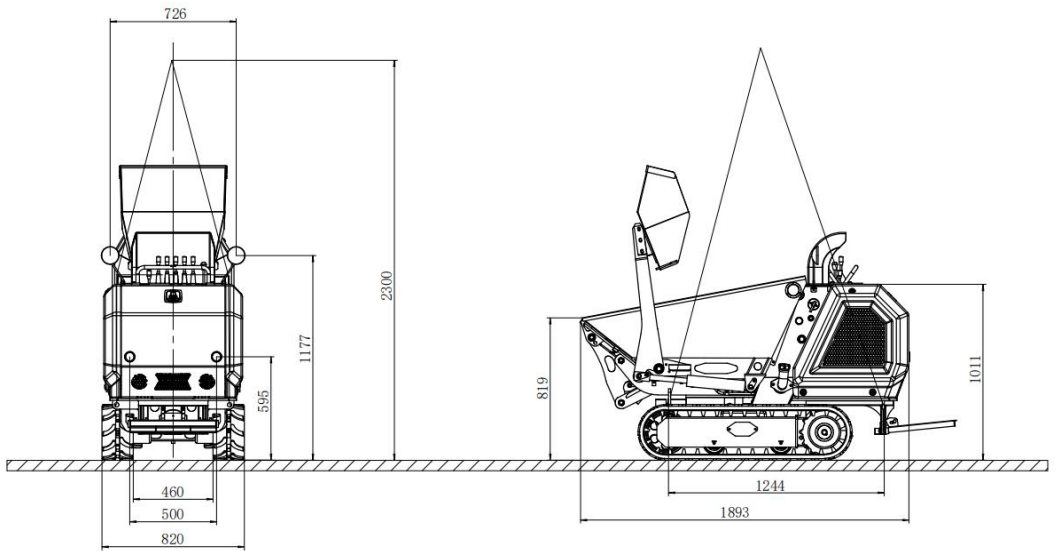

单位: mm



Fixing of Machine

After loading the machine to designated position, fix as per following requirements.

Transport Status

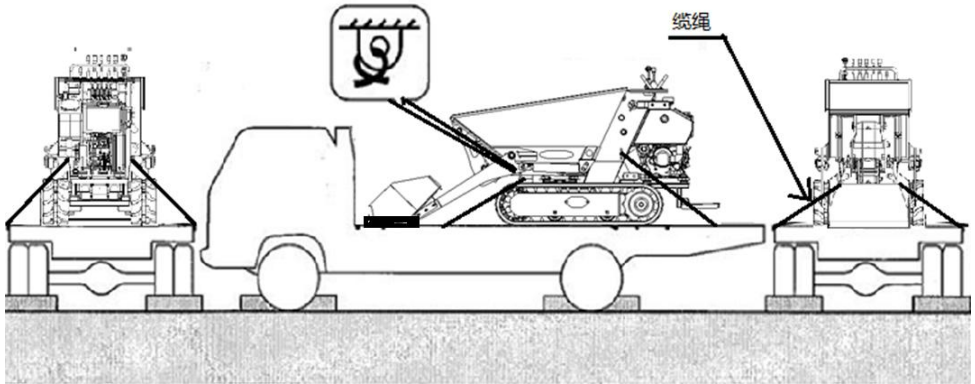

1. Lower the bulldozer blade.
2. Turn off the engine, turn off the power, remove the starting key, and lock all locks.
3. Place stop blocks (wedges) before and after the track.
4. Tie chains or cables to the lower frame of the machine and secure them to prevent machine side slip.
5. Secure the front shovel with a chain or cable.

Important: A wooden block can be placed below the front shovel to prevent damage to the ground by the front shovel.

Safety measures taken during transportation



Warning

- When transporting machines, it is important to understand and comply with applicable safety regulations, vehicle codes, and traffic rules.
- To select the optimal transportation route, consider the length, width, height, and weight of the truck after loading the machine.
- Do not suddenly start or stop or drive at high speed during transportation. Otherwise, it may cause the loaded machine to move or lose balance.

Maintenance





Overview

Maintenance Overview

To maintain the good status and long-term serviceability of the machine, please fulfill the checking and maintenance correctly and safely abide by the procedures recommended by this manual.

Based on the total operating time of the machine, the checking and maintenance items can be divided into several groups: Every 10h (Walk-around checking and daily routine checking), every 50h, and every 250h. Please refer to the reading of hour meter to determine the checking and maintenance timing. The items for which the checking and maintenance intervals can't be determined are listed in column "As necessary".

When the machine is operated in extremely severe environment (Dusty or high temperature environment), fulfill the checking and maintenance ahead of the periods specified by maintenance schedule.

Maintenance Precautions

Do not fulfill any other checking or maintenance item not listed in this manual.

For the items not listed in this manual, please ask your sales or service dealer for help.

Keeping Machine Clean

- Clean the machine before checking and

maintenance. Keep the machine clean.

- Stop the engine before cleaning the machine. Cover the electric parts against water ingress. The water ingress into the electric parts will probably result in short-circuit or malfunction. Do not clean the battery, electronic control units, sensors, connector, or operating room by water or steam.

Fuel, Lubricating Oils, and Greases

- Select fuel, lubricating oils, and greases as per the "Fuel and Lubricant Table".
- Use the water-free fuel, lubricating oil, and grease. Take cautions to eliminate the ingress of dusts during replacement or filling of fuel, lubricating oil, and grease.
- Store the fuel, lubricating oil, and grease in designated location and guard against the ingress of water and dusts.

Precautions for Refueling

- If the fuel filler port is installed with a filter screen, do not remove the filter screen during refueling.
- Please ensure to tighten the fuel tank cap after refueling.
- The refueled volume shall not exceed the designated fuel volume.

No Cleaning of Engine Parts by Fuel

It's prohibited to clean engine parts by fuel. Use



non-inflammable detergent.

Guard against Ingress of Dusts

The installation and disassembling of parts shall be operated in a dust-free place. Clean the working area and clean the parts to guard against ingress of dusts.

Cleaning of Mounting Surfaces

Keep clean the contact surface of parts during the installation and disassembling. If the sealing grooves of the contact surfaces are damaged, please contact your sales or service dealer for repairs or breakup.

Seal Rings and Split Pins

- Ensure to replace all disassembled seal rings and split pins with new ones.
- Take cautions not to damage or twist any seal ring during installation.

Seal Rings

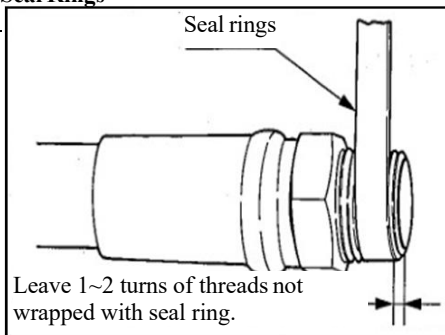

- While wrapping the screw plug with seal ring tape, thoroughly remove the used seal ring tap from the threads and clean the

threads.

- Wrap the threads with seal ring and notice to leave 1~2 end threads of screw plug not wrapped with seal ring.

Waste Disposal

- Ensure to collect the drained oil of machine into a container. The improper treatment of waste oil will pollute the environment.
- While disposing harmful objects, including lubricating oil, fuel, coolant, filter, and battery, please abide by the applicable laws and regulations.

Checking after Maintenance

- Accelerate the engine speed gradually from idling speed to fastest speed and check for leakage of oil or water from repaired parts.
- Operate all joysticks and check machine for normal operations.

Precautions for Wire Connections of Battery

- Before operating the electronic system or performing electric welding, disconnect the wires from both electrodes (+ and -) of the battery.
- Ensure to disconnect it from the grounding electrode (-). Finally connect the grounding electrode during connection.
- Do not disconnect the battery wires during the normal running of engine. Otherwise, the rotary converter circuit or other parts will probably be damaged.



Service Data

Fuel and Lubricant Table

Please refer to following table to select appropriate fuel, lubricating oil, and grease based on the temperature.

- Regardless of the specified periods, replace the oil when the oil is too dirty or already deteriorated.
- Never mix the oils of different trademarks while adding fuel/oil. To replace with fuel/oil of other trademark, please replace completely.

Fuel

Specified fuel

The diesel shall meet the following specification. This table lists some diesel specifications available in the world.

Diesel specification	Region	Diesel specifications	Region
GB252	China	JIS K2204, grade 2	Japan
ASTMD975 No. 1-D, S15 No. 2-D, S15	USA Canada	ISO 8217DMX	Worldwide
Bio-diesel Bio-diesel mixture B5 ASTM D6751, D7467			
EN590 : 2009	EU	BS2869-A1 or A2	UK
Bio-diesel Bio-diesel mixture B5 EN14214, EN590			



Fuel tank	Diesel	<p>To maintain the performance and life of engine, please always use clean and high-quality fuel.</p> <ul style="list-style-type: none">● To prevent freezing in cold weathers, please choose diesel still suitable when the actual temperature is less by at least 12°C than the expected minimum outside temperature.● Please use diesel with cetacean number at 45 or higher. During the operations in low temperature or high altitude regions, use fuel of higher cetacean number.● Use fuel with sulfur content (volume ratio) at <0.5%. Use ultra-low sulfur fuel especially in U.S. and Canada. The use of fuel with high sulfur content can probably result in sulfur acid corrosion in engine cylinders.● Do not mix the diesel with kerosene, used engine oil, or residual fuel. It's prohibited to use kerosene.● The low quality fuel will reduce the engine performance and/or damage the engine.● It's not recommended to use fuel additives. Some fuel additives will deteriorate the engine performances. <p>Safety measure for use of bio-diesel</p> <p>The warranty regulation of the engine manufacturer is void for the engine using disqualified or deteriorated bio-diesel.</p>
-----------	--------	--



Lubricant

Position	Type	Type depending on temperature							Replacement period
		-20	-10	0	10	20	30	40°C	
Oil sump	Diesel engine fuel API: grade CD ACEA:E-3,E-4 or E-5				SAE 10W-30				First 50h * Afterwards every 250h
Hydraulic oil tank	Anti-wear hydraulic oil				SAE 15W-40				Every 2000h ***
Cooling system	Coolant (Water + coolant) ** SAE: J814C or J1034				ISO VG32				Every 1000h
					ISO VG46				
					ISO VG68				
Traveling reducer gear	Gearbox API: GL-4			50% coolant mixture					Every 1000h
				30% coolant mixture					
Slewing motor gear	Lithium-base grease EP-2 MLGI 2#								First 250h * Afterwards every 1000h
Slewing bearing									Every 50h
Working device									Daily or every 10h
Arm									As necessary

*: If the traveling time accounts for a high ratio of the total operating time, replace the gear oil ahead of the specified periods.

** : Use running water (soft water). Do not use well water or river water. If the outside temperature is <0°C, add coolant (antifreeze). Determine the mixture ratio as per the coolant manufacturer's instructions.

***: The replacement period of hydraulic oil depends on the type of hydraulic oil in use. The new machine is filled with Digger King genuine hydraulic oil 46 at the time of delivery and the hydraulic oil replacement periods described in this manual are based on the use of our genuine hydraulic oil 46. When common anti-wear hydraulic oil is used, replace the hydraulic oil once every 2,000h.

API: American Petroleum Institute

ACEA: Association eds Constructors Europeans

SAE: Society of Automotive Engineers



Periodical Replacement of Hydraulic Oil

With installed hydraulic breaking hammer, the hydraulic oil deteriorates faster than the common digging operations. Ensure to replace the hydraulic oil and oil return filter element.

- The failure to replace timely will result in damage of machine and breaking hammer hydraulic system. To prolong the lives of hydraulic devices, please timely replace the hydraulic oil and oil return filter element as per the table below.
- During the replacement of hydraulic oil, clean the oil suction filter screen.

Replacement period (Hour)

Item	Hydraulic oil	Filter element
1 st time	--	25
2 nd time	--	100
Periodic	1200(600)	200

By taking the breaking hammer operating ratio of 100% for instance. Refer to “Hydraulic Breaking Hammer” in page 8-6 for details.

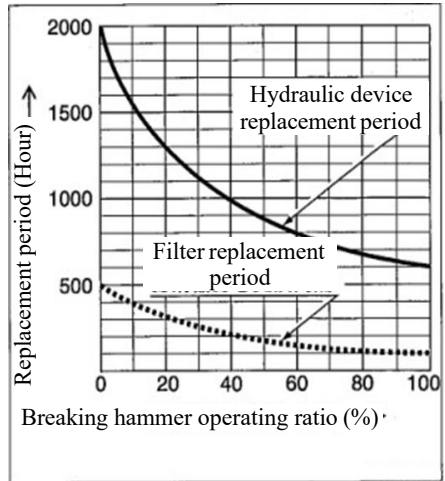

(): For the use of common anti-wear hydraulic oil.



List of Wearing Parts

Periodically replace the wearing parts, including filters and filter elements, as per the table below.

System	Item	Part name	Replacement period
Hydraulic system	Hydraulic suction filter	Filter	first 50 hours and then every 500 hours
	Ventilator		Every 1000h
Fuel system	Fuel filter	Filter cartridge	Every 250h
Air filter system	Air filter	filter	Every 1,000h or 6 cleaning cycles (Whichever comes first)



List of Tools (If installed)

List of tools				
S/N	Name and specification	Unit	Quantity	Remark
1	Tool box	PCs	1	
2	Socket hex. wrench (4mm)	Piece	1	
3	Socket hex. wrench (5mm)	Piece	1	
4	Socket hex. wrench (6mm)	Piece	1	
5	Socket hex. wrench (8mm)	Piece	1	
6	Socket hex. wrench (10mm)	Piece	1	
7	Socket hex. wrench (12mm)	Piece	1	
8	Combination wrench, 8mm	Piece	1	
9	Combination wrench 10mm	Piece	1	
10	Combination wrench 12mm	Piece	1	
11	Combination wrench 13mm	Piece	1	
12	Combination wrench 14mm	Piece	1	
13	Combination wrench 15mm	Piece	1	
14	Combination wrench 16mm	Piece	1	
15	Combination wrench 17mm	Piece	1	
16	Combination wrench 18mm	Piece	1	
17	Combination wrench 19mm	Piece	1	
18	Socket head, 10mm	Piece	1	
19	Socket head 11mm	Piece	1	
20	Socket head 12mm	Piece	1	
21	Socket head 13mm	Piece	1	
22	Socket head 14mm	Piece	1	
23	Socket head 15mm	Piece	1	
24	Socket head 16mm	Piece	1	
25	Socket head 17mm	Piece	1	
26	Socket head 18mm	Piece	1	
27	Socket head 19mm	Piece	1	Extended socket head
28	Socket head 21mm	Piece	1	
29	Socket head 22mm	Piece	1	
30	Curved extension rod, 12.5mm	Piece	1	
31	Short extension rod, 12.5mm	Piece	2	One long and one short each
32	Wire cutter, 200mm	Piece	1	
33	Nipper pliers, 200mm	Piece	1	
34	Ratchet wheel handle, 12.5mm	Piece	1	
35	Adjustable wrench, 300mm	Piece	1	
36	Ball hammer, 1.5pon	Piece	1	
37	Straight screwdriver, 200mm*8mm	Piece	1	
38	Phillips screwdriver, 200mm*8mm	Piece	1	
39	Grease gun, 400g	Piece	1	

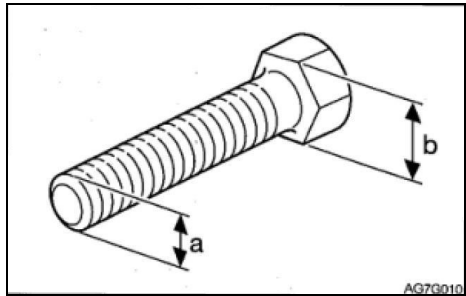
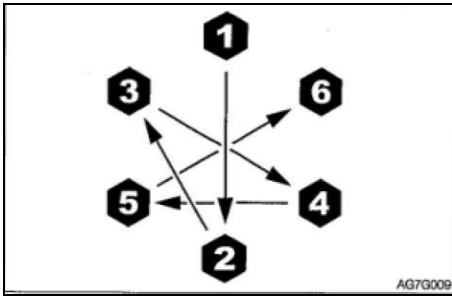

Table of Tightening Torques

Nuts and Bolts (Grade ISO10.9)

Unless otherwise specified, tighten the nuts and bolts to the torques listed in table below.

- The tightening torques for installation of plastic caps are not listed in the table below. To understand more details, please consult with your sales or service dealer. The excessive tightening torque will cause damages.
- If the replacement is required, replace with nuts and bolts of same dimensions and specifications.



Category	Width across flats (b) mm	Dimension (a) X pitch mm	Tightening torque	
			Common connection	
			N·m	Ft·lb
Coarse thread	10	M6 X 1.0	9,8 ±0,5	7, 2±0,4
	12, 13	M8 X 1.25	22,6±1,1	16,6±0,8
	14, 17	M10 X 1.5	47,1±2,4	34, 7 ± 1,7
	17,19	M12 X 1.75	83,4±4,1	61,5±3,0
	19, 22	M14 X 2,0	134,4±6,7	99,1±4,9
	22, 24	M16 X 2.0	207,9±10,4	153, 3 ± 7,7
	27, 30	M20 X 2, 5	410,9±20,5	303,1 ± 15,1
Fine thread	12, 13	M8 X 1.0	24,5±1,2	18,1±0,9
	14, 17	M10 X 1.25	50±2, 5	36,9±1,8
	17, 19	M12 X 1.5	87,3±4,3	64,4 ± 3,2
	19, 22	M14 X 1.5	135, 3±6,8	99,8±5,0
	22, 24	M16 X 1.5	220,6±11	162,7 ± 8,1
	27, 30	M20 X 1.5	452, 1 ±22,6	333,4 ± 16,6



Critical Safety Parts

To operate the machine safely, please fulfill the periodical checking and maintenance. The following critical safety parts shall be replaced periodically to improve safety. These parts can cause serious injuries or fire accident if they are damaged.

List of Critical Safety Parts

organism		Regular replacement of safety critical components	Replacement time
Fuel System		fuel line	Every 2 years
Hydraulic system	host	Hydraulic pipe (pump outlet)	
		Hydraulic pipe (pump suction port)	
		Hydraulic pipe (walking motor)	
	Working device	Hydraulic pipe (lifting cylinder pipeline)	
		Hydraulic pipe (tipping cylinder pipeline)	
		Hydraulic pipe (front shovel cylinder line)	



Maintenance Critical Safety Parts

The materials of the above-mentioned critical safety parts will deteriorate along with time to cause wear or deteriorated performance. It's difficult to determine the deterioration extent during periodical checking. Therefore, such parts shall be replaced with new ones to guarantee stable performance, even if such parts are still working well. Please be noted that, regardless of the replacement schedule, any part with wear symptom must be replaced immediately. Upon detection of any deformed or cracked pipe clamp, immediately replace it together with hose. Please consult with your sales or service dealer for the replacement of safety parts.

Except the critical safety parts, check and tighten the hydraulic pipes and when necessary replace.

During the replacement of hydraulic pipes, replace the O-ring and seal ring as well.

Check the fuel and hydraulic pipes as per the schedule specified by the following table.

Refer to "Maintenance".

Checking type	Checking item
Daily routine checking	Leakage of hydraulic or fuel pipe connector
Monthly checking	Leakage of hydraulic or fuel pipe connector Damage (Cracking, wear, and tear) of hydraulic or fuel pipe
Yearly checking	Leakage of hydraulic or fuel pipe connector Aging, distortion, and damage (Cracking, wear, and tear) of hydraulic or fuel pipe and/or status of hose in contact with other machine parts



Maintenance List

Checking and maintenance item	Page
Walk-Around Checking	
Opening of engine hood and machine hood for checking	5-16
Walk-around checking of machine	5-16
Checking in driver seat	5-16
Daily routine checking (Every 10h)	
Checking and adding of engine oil	5-18
Checking of fuel level	5-18
Checking of hydraulic oil tank oil level and adding of oil	5-19
Lubrication of Working Device	5-21
Every 50h	
Checking and adjustment of track tension	5-23
Lubricate slewing support and slewing motor gears	5-24
Water drainage from fuel tank	5-25
Checking of battery electrolyte level and adding of electrolyte	5-26
Every 250h	
Replacement of engine oil and filter	5-28
Cleaning of air filter	5-29
Checking of accelerator control system	5-30
Replacement of fuel filter	5-31
Every 1000h	
Replace the air filter	5-33
Check and adjust the engine valve clearance	5-33
Every 1500h	
Check and clean the engine fuel injector	5-35
Every 2000h	
Connection of Engine Valve Seats	5-36
Replace hydraulic oil and clean suction filter	5-36



Maintenance
Maintenance List

Maintenance List

Checking and maintenance item	Page
As necessary	
Replace the teeth	5-38
Replace the bucket	5-39
Lubricate joysticks and pedals	5-40
Check the rubber track	5-41
Replace the rubber track	5-42



Walk-Around Checking

Fulfill the following checking before the first start of engine each day.



Warning

- **Before operations, fulfill the walk-around checking and when necessary repair immediately.**
 - **Before operations within the machine, please securely fix the engine hood or machine hood. Keep the engine hood and machine hood closed under windy weather or while parking the machine on a slope.**
-

Before starting the engine, patrol around the machine and remove any combustible materials around the engine. At the same time, check the machine for oil or water leakage, as well as loose or damaged nuts, bolts or wires.

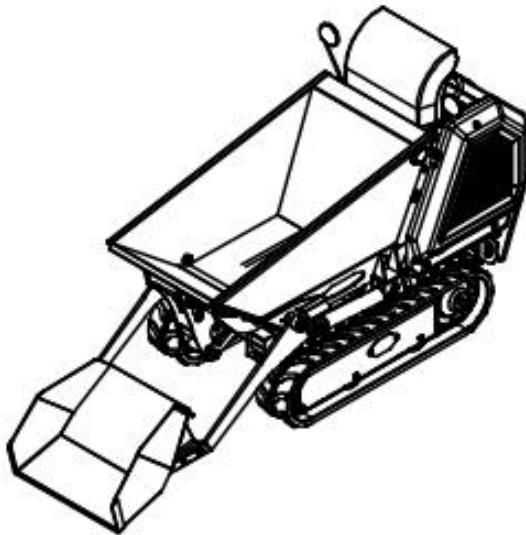



Inspect

1. Check for branches, leaves, oil, or other combustible materials around the engine and battery.
2. Check for leaks of lubricating oil or engine coolant around the engine.
3. Check for oil leaks in hydraulic oil pipes, hydraulic devices, hoses, or joints.

Bypass the machine for inspection

Check for damage to hydraulic accessories and hoses.

Check for damage to the hook and anti slip stop.

Check the handrails, pedals, and anti slip surfaces for damage and loose bolts.

Inspect the tracks, track shoes for slipping, track rollers, idlers, and sprockets for damage, wear, and loose bolts.

Check the walking motor for oil leakage.

Check the protective plate for damage and looseness of nuts and bolts.

Check the label for dust or damage.



Daily routine inspection

Before starting the engine for the first time every day, please perform the following checks.



Warning

- Before operation, please conduct daily routine checks; Repair immediately if necessary.
- Before carrying out work inside the machine, be sure to secure each machine cover.

Check and replenish engine lubricating oil



Warning

Please turn off the engine and wait for the machine to cool down before performing maintenance.

Inspect

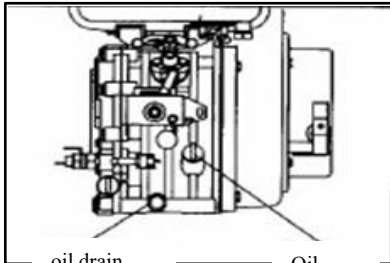

oil drain
plug

Oil
dipstick

- Find and pull out the oil dipstick, and dry the lubricating oil with a cloth.
- Insert the dipstick all the way back in and then pull it out.
- Check the lubricating oil on the dipstick. The oil level should be between the upper and lower limits. If it is below the lower limit, it should be supplemented.

Add oil

- 1.Remove the fuel filler cap.
- 2.Add oil between the upper and lower limits of the dipstick.
- 3.Problems can occur if the oil level is too high or too low.
- 4.Start the engine and run at low idle for 5 minutes before turning off the engine.
- 5.After about 10 minutes, check the oil level.

Check fuel level



Warning

- Do not smoke or open flames when handling fuel or working on fuel systems.
- Do not remove the fuel tank cap or add fuel when the engine is running normally or has not cooled down yet. Do not sprinkle fuel on the high-temperature surface of the machine.
- Fill the fuel tank in a well ventilated area.
- Spilled fuel should be wiped clean immediately.
- Do not top up the fuel tank. There should be room for oil expansion.
- Tighten the fuel tank cap firmly.
- Use the correct fuel level according to the season.

Refueling

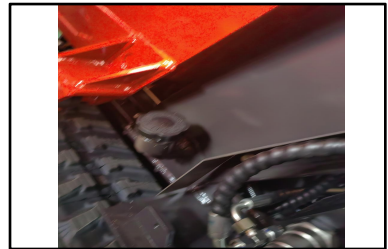

- 1.Check the fuel level.
- 2.If the fuel level is low, open the fuel tank cap to top up.



Check the oil level of the hydraulic oil tank and replenish it



Warning

1. Before the hydraulic system is depressurized, if the cover or filter is removed or the pipeline is disconnected, hydraulic oil may spray out.
 1. Slowly loosen the air plug to relieve the pressure inside the box.
1. inspect
2. The oil level will vary with the oil temperature. Maintain the machine with the posture shown in the following figure and check the fuel condition.
3. Machine posture when checking hydraulic oil level

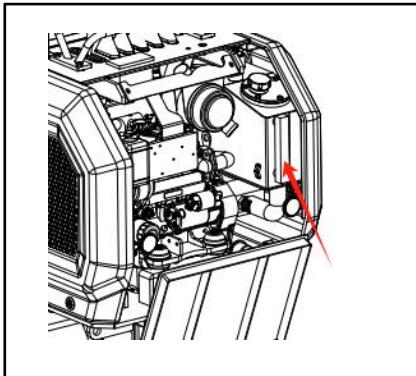

1. Start the engine and run at low speed.
2. Fully retract the oil cylinder.
3. Lower the front shovel and turn off the engine.
4. Check the oil level with a Level sensor.

When the oil temperature is about 20 °C: the oil level line should be above the observation hole. If it is lower than the observation hole, it should be supplemented.

When the oil temperature is about 50 to 80 °C: the oil level should be slightly below the upper limit.

Replenish hydraulic oil

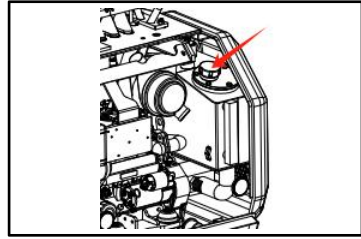

1. Adding hydraulic oil is important: do not add it above the observation hole when refueling. This can damage the hydraulic circuit or cause oil injection. If accidentally done, turn off the engine, wait for the hydraulic oil to cool down, and then drain the excess oil from the drain port.

Important: Please do not forget to apply pressure to the hydraulic oil tank to avoid damage to the pump due to air suction. (If not equipped with a ventilator).

1. Slowly loosen the air plug to relieve internal pressure, then remove it.
2. Add hydraulic oil to the middle of the observation hole.
3. Pressurize the hydraulic oil tank as shown in the following figure.

Attachment: For machines equipped with ventilators, pressurization is not required.

Pressurized hydraulic oil tank

1. Start the engine and run at low speed.
2. Remove the exhaust plug.
3. Fully extend the tilting bucket, front shovel, and lifting device cylinder.
4. Turn off the engine, tighten the exhaust plug, and then apply pressure by retracting the cylinder.



Lubrication working device

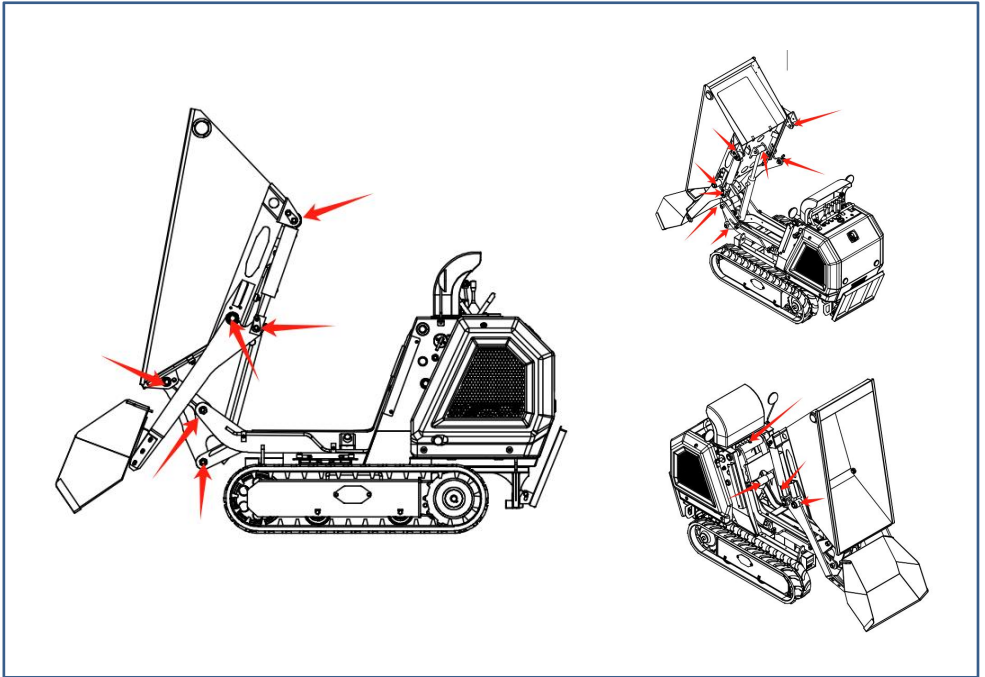

1. Maintain the machine in the posture shown in the above figure, lower the lifting device to the stop, lift the tipper and insert the limit pin, lower the front shovel to the ground, and then turn off the engine.
2. Use a Grease gun to lubricate the grease fittings.
3. Wipe off excess grease

Records



Every 50 hours

Check and adjust the tension of the track



Warning

- If it is necessary to work under a raised machine or working device, be sure to use wooden blocks, jacks, or other stable and sturdy supports. Do not get under the machine or working device until it is firmly supported.

Check

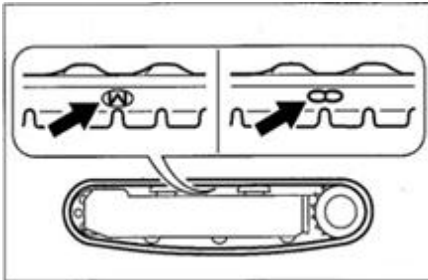

1. If it is a rubber track, place the "M" mark at the joint
The upper center of the track frame.

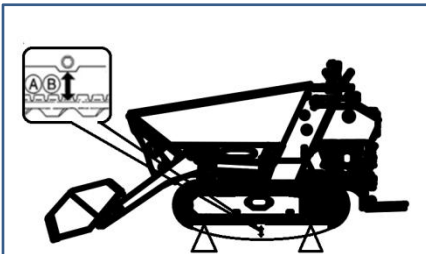

2. Use the working device to lift the body.
Slowly operate the control lever.

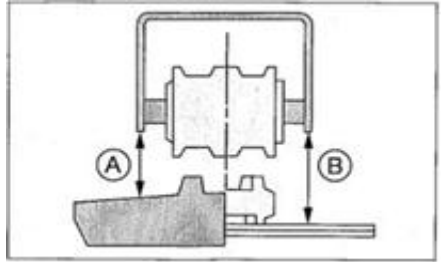

3. Check the distance between the bottom surface of the frame in the middle of the track frame and the top surface of the track

Gap (A or B).

The gap (A or B) needs to be within the following range:

Rubber track 35 to 50 mm



adjustment

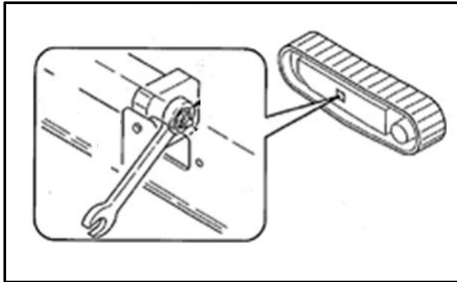

adjustment

Increase tightening force

Remove the cover plate.

Slowly rotate the tensioning bolt
clockwise with a wrench.

Check the tension of the track.

Reduce tightening force

Remove the cover plate.

Slowly rotate the tensioning bolt
counterclockwise with a wrench.

Check the tension of the track.



Check the battery liquid level



Warning

Do not use batteries when the liquid level is below the lower limit. Otherwise, it will accelerate the internal aging of the battery and shorten its lifespan. It can also cause rupture (explosion).

Batteries can generate flammable hydrogen gas, which may cause explosions. Stay away from open flames, sparks, or lit cigarettes and other sources of ignition.

Clean the area above the electrolyte level line with a damp cloth and check the liquid level. Do not use a dry cloth for cleaning; Otherwise, it can cause static electricity to accumulate and cause combustion or explosion.



Warning

- When operating the battery, one should wear protective goggles and protective clothing.
- Do not add distilled water above the upper limit. Otherwise, it will cause the electrolyte to leak out. Contact with this liquid can damage the skin or corrode machine components.
- The battery contains sulfuric acid, which can damage the eyes or skin if accidentally touched.
- If accidentally enters the eyes, rinse immediately with water and seek medical attention promptly.
- If swallowed accidentally, drink plenty of water or milk and seek medical attention immediately.
- If sulfuric acid comes into contact with skin or clothing, it should be immediately washed off with plenty of water.

Checking

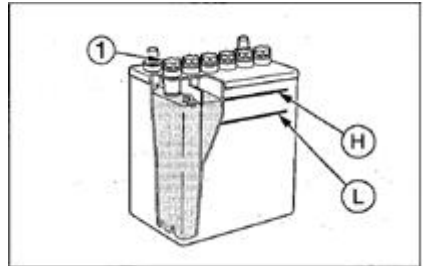

1. Open the maintenance cover.
2. Check the fluid level. The fluid level must be between upper limit (H) and lower limit (L). If not, add distilled water till the fluid level reaches upper limit (H).
3. Check terminals for looseness and contamination.

Adding

If the adding of distilled water is required, add water before start of operations, in order to prevent freezing.

1. Take out the cap (1) and add distilled water till the upper limit (H) is reached.
2. Clean the ventilation port on the cap and securely tighten the cap (1).



Every 200h

Replace the engine lubricating oil and oil filter



Warning

Please turn off the engine and wait for the machine to cool down before performing maintenance.

The engine, exhaust pipes, radiator, hydraulic pipes, sliding components, and many other parts of the machine are very hot when the engine is just turned off. Touching these parts can cause burns.

The engine oil is also very hot. Be careful not to touch the hydraulic oil when loosening the cover or plug. Performing machine operations in this situation can cause burns or injuries.

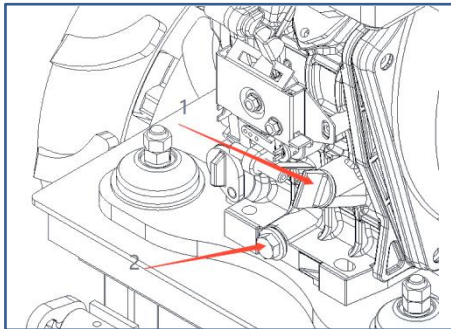

1. Find and remove the fuel filler (1).

Place a plate under the drain plug (2) to hold the waste oil.

Remove the oil drain plug (2) to drain the engine oil.

Important: Check for metal powder in the waste oil.

If it contains a large amount of metal powder, please consult your sales or service agent.

Remove the old oil filter and insert a new filter

Press on the oil drain plug (2) and tighten it with a wrench.

Add lubricating oil between the upper and lower limits of the dipstick (1). If the oil level is too low or too high, it can cause problems.

Tighten the fuel filler cap.

Start the engine and run at low idle for 5 minutes before turning off the engine.

After about 10 minutes, check the oil level.

Replacement of oil filter

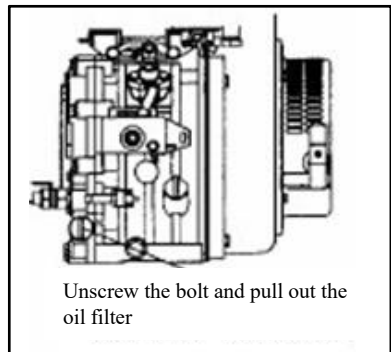

Unscrew the bolt and pull out the oil filter



Clean the air filter



Warning

- Please turn off the engine and wait for the machine to cool down before performing maintenance.
- The engine, exhaust pipes, radiator, and many other parts of the machine are very hot when the engine is just turned off. Touching it can cause burns.
- When using compressed air, please wear necessary protective equipment, such as goggles and filter masks, as metal fragments and other objects can splash and cause serious injury accidents.

Important: Be careful not to scratch the filter element. Do not use damaged filter elements.

Important: When operating the machine in a dusty environment, please inspect and maintain the machine daily.

Important: Be sure to securely install the filter element and dust cover. Otherwise, dust being sucked into the cylinder can cause engine damage.

1. Find the air filter.
2. Loosen the butterfly nut and remove the outer shell.

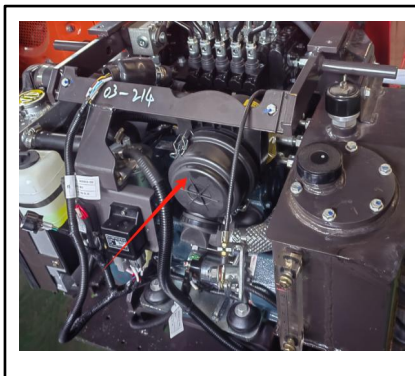

3. Loosen the nut and remove the filter element.

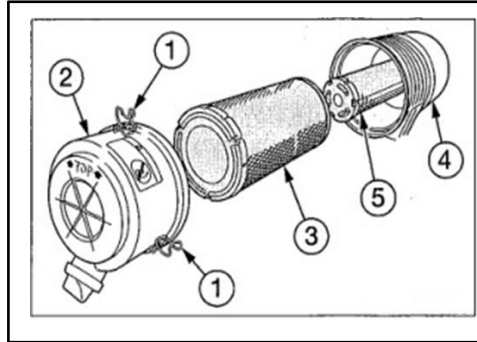

4. Cover the entrance on the back of the body with a cloth or tape to prevent dust from entering.
5. Clean the interior of the casing.
6. Clean the filter element with dry compressed air (294 to 490kPa). First, blow air from inside the filter element along the crease. Then blow air from the outside, and finally blow air from the inside.
7. Use a light bulb to illuminate the inside of the filter element for inspection. If any small holes or stains are found, replace them.
8. Install the filter element and tighten it.
9. Install the casing and tighten it.



Check the throttle control system

- The throttle control lever and governor located on the engine side are connected by cables. Check if the throttle cable is stretched or loose in its fixed position.
- If the throttle cable is stretched or loosened in a fixed position, a malfunction may occur.
- Experience is required for replacing or adjusting the throttle cable. Please entrust your sales or service agent to do so.

Diesel filter replacement

Remove the diesel filter from the fuel tank and replace it.

Drain all fuel from the tank

Unscrew the drain bolt and fastening nut on the fuel tank switch.

Remove the filter from the fuel tank and insert a new filter.



Fuel tank exhaust

The specific method is to unscrew the nut connecting the fuel injection pump and high-pressure oil pipe, press the pressure reducing handle, pull the starting device back and forth to pump oil, release air, until no bubbles emerge from the fuel.



Every 1000h

Replace the air filter

For details, refer to "Cleaning the Air Filter" on page 5-29.



Warning

Please stop the engine and wait for the machine to cool down before maintenance. .

- **The engine, exhaust pipe, radiator, and many other machine parts are really hot when the engine is just stopped.**

Touching such parts can cause scalding.

Important: Do not use a wrinkled filter element or a filter element with damaged washer or seal ring.

Important: Ensure to steadily install the filter element and dust cover. Otherwise, the ingress of dusts into the cylinders will damage the engine.

Checking and Adjustment of Engine Valve Clearance

These operations require experiences. Please ask your sales or service dealer for operations.



Maintenance
Every 1500h

Every 1500-hour

Checking and Cleaning of Engine Fuel Injector Nozzles

These operations require experiences. Please
ask your sales or service dealer for operations.



Every 2000h

Replace hydraulic oil and clean oil suction filter element



Warning

- Please turn off the engine and wait for the machine to cool down before performing maintenance.
- The engine, hydraulic system, and many other parts of the machine are very hot when the engine is turned off. Touching these parts can cause burns.
- The hydraulic oil is also under high temperature and pressure. Be careful not to touch the hydraulic oil when loosening the cover or plug. Operating the machine in this situation can cause burns and injuries due to hot oil spraying.
- Before the hydraulic system is depressurized, if the cover or filter is removed or the pipeline is disconnected, hydraulic oil may spray out.
- Slowly loosen the exhaust plug to release the fuel tank pressure.
- When removing plugs or bolts or disconnecting hoses, stand on one side and slowly loosen them to gradually relieve internal pressure before removing them.

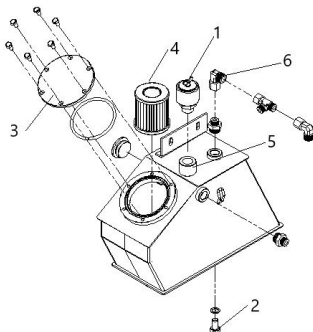

1. Adjust the machine to the hydraulic oil level check posture. Please refer to "Checking the Hydraulic Oil Tank Level and Replenishing" on pages 5-17 for details.
2. Slowly loosen the air plug (1) to reduce internal pressure, then lower the plug.
3. Place a plate under the oil drain plug (2) to hold the waste oil.
4. Loosen the oil drain plug (2) and drain the hydraulic oil.
5. Loosen the bolts and remove the flange (3).
6. Loosen the bolts, remove the oil suction filter element (4), and clean it.
7. Clean the inside of the hydraulic oil tank.
8. Replace the vent plug (1) (if equipped).
9. Install the oil suction filter element (4) into the oil tank.
10. Install the flange (3) back into its original position.
11. Tighten the oil drain plug (2).
12. Remove the thread head (6).
13. Fill hydraulic oil from the wire block (5) to the middle position of the circular oil mark.
14. Place the thread head (6) in position and tighten it.
15. Pressurize the hydraulic oil tank. (If not equipped with a breather, refer to "Pressurized Hydraulic Oil Tank" on pages 5-18).
16. Install the vent plug (7).
17. Remove the air from the hydraulic oil circuit as described in the "Exhaust" section below.
18. Adjust the machine to the hydraulic oil level check position and check the oil level after the oil temperature drops.
19. (Please refer to "Checking the hydraulic oil tank level and supplementing" in this section for details)



exhaust

Important: After replacing the hydraulic oil, the air in the hydraulic pipeline and hydraulic device should be discharged. Otherwise, it may damage the hydraulic device.

Oil cylinder

Start the engine and run at low speed for 10 minutes.

Keep the engine running at low idle, then extend and retract each cylinder 4 or 5 times, taking care not to extend (retract) the cylinder to the end.

Run the engine at high speed, then extend and retract each cylinder 4 or 5 times, taking care not to extend (retract) the cylinder to its end.

Return the engine speed to low idle, then extend and retract each cylinder 4 or 5 times, all the way to the end.



Lubrication rod



Warning

Adjust the machine to a stopped position, turn off the engine, remove the start key, and store it. Otherwise, the machine may suddenly move, causing serious injury or death.

If the control lever cannot be flexibly operated, please lubricate with oil.

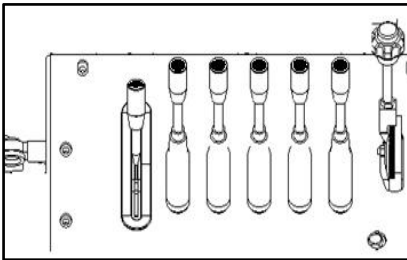

Check rubber tracks

If the condition of the rubber track becomes as follows, please repair or replace it. For details on repair or replacement, please consult your distributor or service agent.

Rubber track

If the entire track is stretched and cannot be adjusted, please replace the track.

(1) Convex block

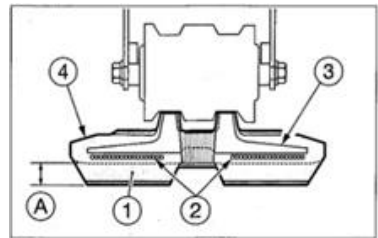

If the height of (A) is 5 millimeters or less, please replace it.

(2) Steel rope

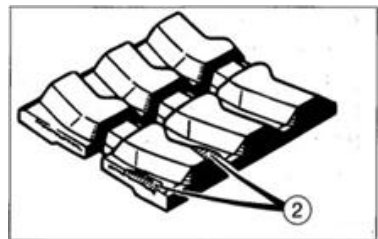

If two or more sections of the steel rope are exposed, please replace them.

If half or more of the side of the steel rope is cut, please replace it.



(3) Metal core

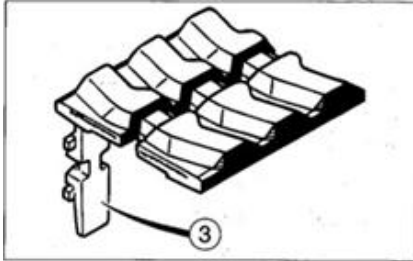

Even if one metal core falls off, it needs to be replaced.

(4) Rubber

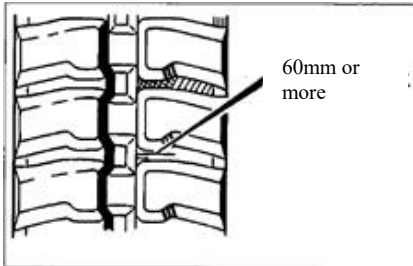

If the crack length is 60 millimeters or longer, please repair it. If the steel rope is visible, regardless of the length of the crack, please repair it as soon as possible.

Replacing rubber tracks



Warning

- If it is necessary to work under a raised machine or working device, be sure to use wooden blocks, jacks, or other stable and sturdy supports. Do not get under the machine or working device until it is firmly supported.
- If maintenance must be carried out while the engine is running, arrangements should be made
- Two people work as a team and maintain communication with each other.
- One person must be in the driving position in order to immediately turn off the engine if necessary. This person must be particularly careful not to touch the control lever or foot pedal, except when necessary.
- The other person performing maintenance must ensure that their body or clothing is kept away from moving parts of the machine.



disassembly

1. Fully relax the tension of the rubber track.

Please refer to Part 5 "Checking and Adjusting the Track Tensioning Force" for details.

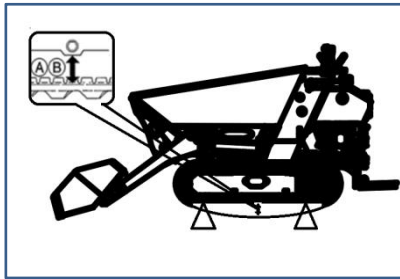

2. Use the working device to lift the body.

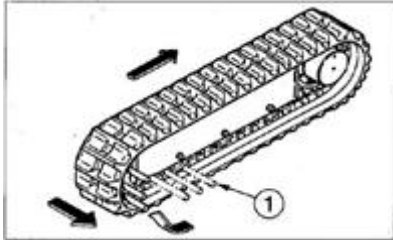

3. Place an iron pipe (1) in the rubber track and slowly rotate the sprocket in the opposite direction.
4. Rotate the sprocket until the iron pipe (1) is tightly against the tensioning wheel and the rubber track is lifted away from the tensioning wheel, then stop rotating the sprocket.
5. Slide the rubber track horizontally and remove it from the track frame. Follow the same procedure to remove another rubber strap.

install

1. Use the working device to lift the engine body

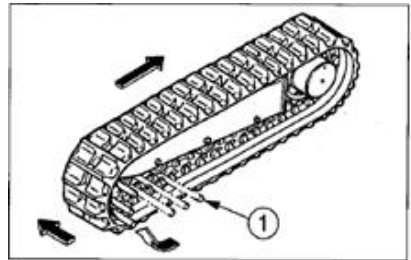

2. Place rubber tracks on the sprocket.
3. Place an iron pipe (1) in the rubber track and slowly rotate the sprocket in the opposite direction.
4. Rotate the sprocket until the iron pipe (1) is tightly against the tensioning wheel and the rubber track is lifted away from the tensioning wheel, then stop rotating the sprocket.
5. Slide the rubber cover inward, install it onto the tensioning wheel, and then pull out the iron pipe.
6. Check if the rubber track is securely installed on the sprocket and check for tension
7. On the wheel.
8. Tighten the rubber track to the standard tension.
9. Please refer to "Checking and Adjusting the Track Tensioning Force" in Part 5 for details.
10. Install another rubber track according to the same procedure.



Maintenance during Long-Time Parking

Parking Procedure

If it's necessary to park the machine for ≥ 30 days, please park the machine indoors. If it's necessary to park outdoors, please park the machine on a wood-paved level ground and cover the machine by water-proof cap to keep dry.

1. Clean the machine.
2. Check for oil/water leakage and cracking and check for any loose nut or bolt.
3. Refuel and replace hydraulic oil and lubricating oil.
4. Lubricate the grease fitting by a grease gun.
5. Fully retract the bucket and bucket arm cylinders and lower the bucket and bulldozing blade onto the ground.
6. Apply anti-rusting oil to the hydraulic cylinders.
7. Disconnect the negative cable of battery and cover the battery to guard against freezing.

During Parking



Warning

- **Do not operate the machine in an enclosed place with poor ventilation.**
 - **If the natural ventilation is not possible, install ventilation fan, fan, extended exhaust pipe, or other ventilation device.**
-

1. To prevent rusting, operate the machine once a month to circulate the oil throughout whole system.
2. Check the battery and when necessary charge the battery. Please ask your sales or service dealer for charging.

Start of Machine after Parking

Important: If the above-mentioned

“Parking procedure” is not followed during the long-time parking of machine, please consult with your sales or service dealer before restarting the machine.

1. Wipe away the lubricating oil from the piston rods of the hydraulic cylinders.
2. When necessary, add lubricating oil or grease.

Reuse of Engine

1. Fulfill the daily checking.
2. Pre-lubricate the engine before start.
 - a. Crank the engine for 15s and notice to keep the fuel system closed to prevent start of engine.



- b. Stop for 30s.
 - c. Repeat this procedure, till the engine is already cranked for 1min in total.
This can enable the sufficient oil circulation throughout the lubrication system of engine.
2. Get ready the fuel system.
 3. Start the engine. Idle the engine for approximately 15min and then:
 - Check for normal oil pressure.
 - Check for leakage of fuel, engine oil, and coolant and check indicator lamps and/or level gauge for normal functioning.
5. Avoid operating for a long time at minimum or maximum engine speed or operating the loaded residue within the first loading hour.

Troubleshooting





No Battery Power

The following symptoms indicate no battery power.

- No rotation of starter motor or start failure of engine.
- Low volume of horn.

Remedy procedure

Start the engine by the booster battery on other machine (booster machine) and jumper cable.

Warning

- To start the engine by jumper cable, ensure to connect the cable by correct procedure. The improper use of jumper cable will result in battery explosion or unexpected machine motions.
- The booster machine and the machine with depleted battery are prohibited for mutual contact.
- The positive (+) and negative (-) clamps of the jumper cable are prohibited for mutual contact.
- During connection, firstly connect the jumper cable to positive (+) terminal. During disconnection, firstly disconnect the cable from negative (-) terminal.
- Connect the last clamp of jumper cable to a point as far as possible from the battery.
- Always wear goggles while using jumper

cable to start engine.

Important: The jumper cable and clamps in use shall be suitable to the battery capacity. Do not use any damaged or corroded jumper cable or clamp.

Important: Ensure the same capacity for the battery on the rescue machine and the battery on malfunctioned machine.

Important: Ensure to connect the cable clamps securely.

Connection of Jumper Cable

Important: Place the starter keys of both rescue machine and malfunctioned machine to OFF.

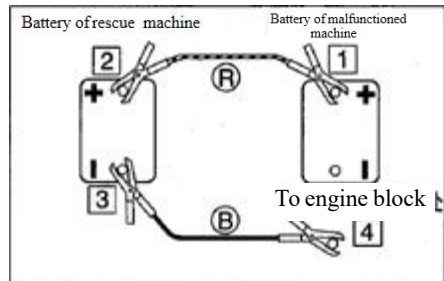

1. Connect a clamp of jumper cable (R) to the positive (+) pole of malfunctioned machine.
2. Connect the other jumper cable clamp (R) to the booster (+).
3. Connect the jumper cable clamp (B) to the charger (-).
4. Connect the other clamp of jumper cable



Troubleshooting No Battery Power

(B) to the engine support of the malfunctioned machine. Connect the clamp to a point as far as possible from the battery.

After Start of Engine

1. Check and ensure that the wire clamps are already connected securely to various terminals.
2. Start the engine of rescue machine and run it at high speed.
3. Start the engine of the malfunctioned machine.

Disconnection of Jumper Cable

After the successful start of the engine of malfunctioned machine, disconnect the jumper cable in reverse sequence of the connection procedure.

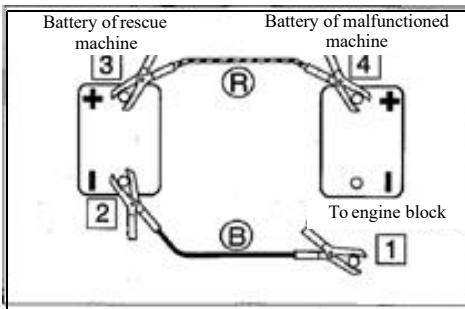

1. Disconnect the clamp of jumper cable (B) from the engine support of malfunctioned machine.
2. Disconnect the other jumper cable (B)

from the charger (-).

3. Disconnect the jumper cable (R) clamp from the charger (+).
4. Disconnect the jumper cable clamp (R) from the uncharged machine (+).

Recharging

Please ask your sales or service dealer to recharge the depleted battery.



Other Symptoms

For the symptoms not listed in table below or the further existed problems after appropriate solutions, please consult with your sales or service dealer.

Problem	Cause	Solutions
The left and right joysticks cannot move flexibly	<ul style="list-style-type: none">● Lack of grease on left and right joysticks	<ul style="list-style-type: none">● Lubricate the joystick
Bucket, slewing or walking operations cannot be performed	<ul style="list-style-type: none">● The safety lock lever has been raised (locked)	<ul style="list-style-type: none">● Lower (release) the safety lock lever. Please refer to page 2-11.
Not enough digging power	<ul style="list-style-type: none">● Hydraulic oil level is too low● The hydraulic oil is not hot enough● Air filter is clogged● Incorrect hydraulic oil type	<ul style="list-style-type: none">● Add to the specified liquid level. Please refer to page 5-19.● Clean the air filter. Please refer to page 5-29.● Replace hydraulic oil. Please refer to page 5-36.
Unable to walk or inflexible	<ul style="list-style-type: none">● Stone or foreign object stuck	<ul style="list-style-type: none">● Remove foreign objects
The machine turns right/left	<ul style="list-style-type: none">● A stone or foreign object is stuck.● The track tension adjustment is faulty	<ul style="list-style-type: none">● Remove foreign objects● Adjust the track to the specified tension. Please refer to page 5-23.



Problem	Cause	Solutions
Can't turn or turn inflexibly	<ul style="list-style-type: none">● Insufficient grease for slewing support	<ul style="list-style-type: none">● Lubricate the bearings Please refer to page 5-24
The hydraulic oil temperature is too high	<ul style="list-style-type: none">● Hydraulic oil level is too low	<ul style="list-style-type: none">● Add to the specified liquid level. Please refer to page 5-19
The starter motor rotates but the engine does not start	<ul style="list-style-type: none">● Insufficient fuel● There is air in the fuel system● Water in the fuel system	<ul style="list-style-type: none">● Add fuel. Please refer to page 5-18.● Exclude air. Please refer to pages 6-7.● Drain the water. Please refer to pages 5-25.
Tracks fall off	<ul style="list-style-type: none">● Tracks are too loose	<ul style="list-style-type: none">● Increase the tension. Please refer to page 5-23.
The engine emits black smoke from time to time	<ul style="list-style-type: none">● Air filter is clogged	<ul style="list-style-type: none">● Clean the air filter. Please refer to pages 5-29.
Engine exhausts white or blue smoke	<ul style="list-style-type: none">● Too much oil● Inferior fuel	<ul style="list-style-type: none">● Adjust to the specified liquid level. Please refer to page 5-18.● Change the fuel.
The engine produces irregular noise (combustion or mechanical noise)	<ul style="list-style-type: none">● Inferior fuel is being used	<ul style="list-style-type: none">● Replace the fuel
	<ul style="list-style-type: none">● Internal damage of exhaust pipe	<ul style="list-style-type: none">● Replace the exhaust pipe. For replacement matters, please consult your sales or service agent.



Common faults and troubleshooting methods of diesel engines

1. Difficulty starting

Fault characteristics and causes	Exclusion method
<ul style="list-style-type: none"> ● Cold weather, sticky engine oil, difficult to start 	<ul style="list-style-type: none"> ● Use the specified grade of engine oil, or preheat the engine oil and inject it into the oil pan, but do not bake the oil pan;
Fuel system malfunction Poor diesel circulation Diesel freezing There is air inside the oil pipe The needle valve of the fuel injector is stuck, carbon deposits are formed in the injection hole, and the pressure is low Wear of fuel injection pump plunger	<ul style="list-style-type: none"> ● Check for moisture and other dirt inside the fuel tank and diesel filter element. If the filter element is blocked by dirt, clean it with clean diesel or replace the filter element. If there is moisture in the diesel, clean the fuel tank and oil pipe, and replace the diesel. ● Use diesel of the specified brand. ● Release the air and tighten all oil pipe fittings. ● Clean, grind or replace the fuel injector components, and adjust the fuel injection pressure to the specified value. ● Replace the plunger components.
Insufficient compression force Excessive wear on piston rings, pistons, or cylinder liners Poor sealing, air leakage, or incorrect clearance between the valve and valve seat The cylinder head nut is not tightened or the cylinder gasket is burnt out	<ul style="list-style-type: none"> ● Replace piston rings, pistons, or cylinder liners. ● Grind the intake and exhaust valves and valve seats, replace them if necessary, check the valve clearance and adjust it to the specified value.

2. Insufficient power

Fault characteristics and causes	Exclusion method
Insufficient compression force The gap between the intake and exhaust valves is incorrect Air filter blockage Poor diesel fuel supply Speed too low Worn fuel injector components or incorrect fuel injection pressure	<ul style="list-style-type: none"> ● Refer to the troubleshooting method in "Difficulty to Start" fault 3 ● Adjust according to regulations ● Clean or replace the filter element with clean diesel or kerosene ● Check the fuel tank switch, clean the diesel filter and oil circuit ● Adjust the speed control handle to reach the specified speed. ● Troubleshooting according to the 5th method of "Fuel System Fault" in Fault 2 of "Difficulty to Start"

3. Diesel engine self parking

Fault characteristics and causes	Exclusion method
<ul style="list-style-type: none"> ● Diesel interruption 	<ul style="list-style-type: none"> ● If there is too little diesel in the fuel tank, immediately add enough. If the oil pipeline and diesel filter are blocked or leaking, remove dirt and air.
<ul style="list-style-type: none"> ● Insufficient engine oil or lubrication system malfunction causing bearing shells to bite 	<ul style="list-style-type: none"> ● Check the oil level with an oil dipstick, and add it if it is insufficient.
<ul style="list-style-type: none"> ● Fuel injector components are stuck 	<ul style="list-style-type: none"> ● The fuel injector components should be cleaned and ground, and replaced if necessary.



4. Exhaust emits black smoke

Fault characteristics and causes	Exclusion method
<ul style="list-style-type: none"> ● Diesel engine overload 	<ul style="list-style-type: none"> ● Reduce the load appropriately, and if the matching equipment does not match, it should be adjusted
<ul style="list-style-type: none"> ● Poor atomization of fuel injectors 	<ul style="list-style-type: none"> ● Check the injection pressure and spray condition and correct them. If they are damaged, replace them
<ul style="list-style-type: none"> ● Air filter blockage 	<ul style="list-style-type: none"> ● Clean and replace the filter element
<ul style="list-style-type: none"> ● Cylinder leakage and insufficient compression force 	<ul style="list-style-type: none"> ● Use the method of "difficult to start" and "insufficient compression force" to troubleshoot
<ul style="list-style-type: none"> ● High internal friction resistance and lubrication system malfunction 	<ul style="list-style-type: none"> ● Lubrication system faults and oil passage blockages have caused various friction pairs to bite and pull, and have been resolved.

5. Other faults

Fault characteristics and causes	Exclusion method
<p>Excessive oil leakage from the exhaust port</p> <ul style="list-style-type: none"> ● Wear of piston and cylinder liner ● Worn valve guide ● Adhesion, wear, or breakage of piston rings ● Install the second piston ring upside down ● Excessive oil filling 	<ul style="list-style-type: none"> ● replace ● replace ● Cleaning or replacement ● Dismantle and reassemble ● Drain the oil to the normal level
<p>Fuel injectors often get stuck</p> <ul style="list-style-type: none"> ● Rapid parking under high temperature ● Diesel fuel not clean, diesel filter damaged 	<ul style="list-style-type: none"> ● To avoid rapid parking under high temperatures, gradually unload the load and reduce the speed to stop. Clean the fuel system, replace the clean diesel and diesel filter.
<ul style="list-style-type: none"> ● The red mark on the oil pressure indicator valve suddenly drops 	<ul style="list-style-type: none"> ● Check the lubrication system, such as whether the filter and lubrication oil passage are blocked, whether the oil pump is normal, whether the oil level is sufficient, and take corresponding measures to eliminate it.
<ul style="list-style-type: none"> ● The speed fluctuates from high to low or increases sharply 	<ul style="list-style-type: none"> ● Check if the lubrication system is functioning properly, whether there is air in the oil pipeline, and take corresponding measures to eliminate it. When the engine speed increases sharply (speeding), block the intake pipe (avoid blocking it directly with your hands) or cut off the oil circuit.
<ul style="list-style-type: none"> ● Sudden abnormal noise 	<ul style="list-style-type: none"> ● Immediately stop the machine and carefully inspect every moving part



traction

Improper operation, unsuitable cable, or improper cable inspection during towing can lead to serious injury or death.

If the cable breaks or detaches, there is a danger.

Use cables that match the traction force.

Do not use twisted, twisted, or even damaged cables.

Do not suddenly apply heavy loads on the cable.

When handling cables, please wear safety gloves.

Ensure that there is one operator on each machine being towed and one operator on each machine being towed.

Do not tow on slopes.

Please do not approach the cable when towing.

Important: If the engine is not started or the machine is not running, do not tow the machine. Doing so may damage the towed machine.

Important: When using traction holes for traction, please strictly follow the following steps. Failure to pay attention to any of these steps may result in damage to the traction hole or other parts of the frame.

Towing machines

Use the following procedure to tow heavy objects or machines that are stuck in mud and cannot be driven out by themselves.

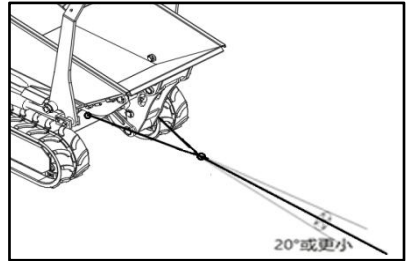

- Allowable force: 28.2 KN
- Tie the cable to the hook and loop.
- Hook the hook and loop onto the traction hole.
- Ensure that the cable maintains a cone angle of 20 ° or less with the walking frame.
- Move the machine and tighten the cable.
- Move the machine at a low speed of 2 km/h or lower to a location that is relatively short from the site (convenient for maintenance).

Parameters





Applicable models: SB890

	Technical parameters	UNIT	
Operating weight		Kg	870
maximum payload		Kg	800
Bucket capacity		m ³	0.26
Type of working device			Self loading and unloading
Engine	Model		KUBOTAD722
	Displacement	L	0.719
	Rated output power/speed	Kw/r/min	10.2/2500
	Maximum torque/rotating speed	N.m/r/min	42.9/2000
	Net weight	Kg	63.1
	External dimensions	mm	426*389*520
Speed	Maximum traveling speed (High/low)	km/h	4.0
	Minimum walking speed	km/h	2.0
	Maximum grade ability		30°
Tracks	Ground pressure	Kpa	26.13
	Material		Rubber
	Tension control type		Screw adjustment
Pump			Gear double pump
Tank capacity	Working pressure	Mpa	16
	Flow	L/min	30
	Hydraulic oil tank capacity	L	14
	Fuel tank capacity	L	16

All ratings of the machine are obtained when the machine is operating on a solid horizontal support surface. If the working environment conditions of the machine differ from the above-mentioned reference conditions (Such as the operations on uneven ground and slope), the operator shall take these conditions into consideration.



Applicable models: SB890

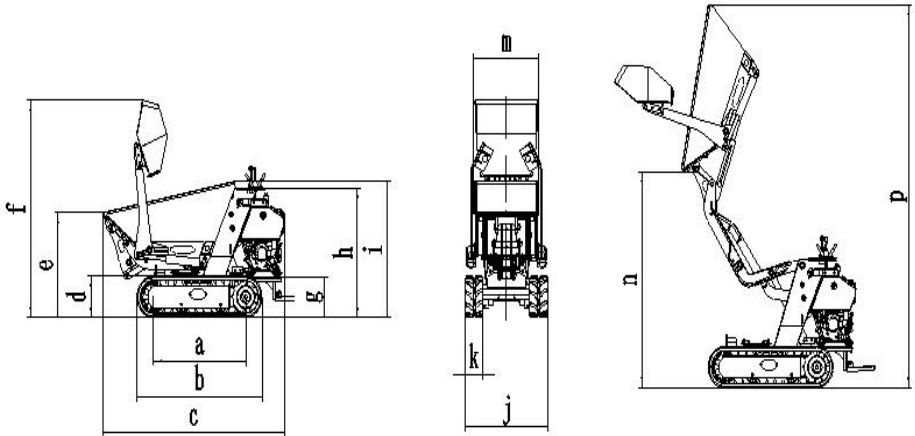

a Track width	914mm
b Track length	1230mm
c length	1795mm
d Track Height	320mm
e Front end height of tipping bucket	810mm
f Height from self loading bucket to ground	1690mm
g Platform off ground	315mm
h Control console height above ground	1005mm
i Rear end height of tipping bucket	1060mm
j width	820mm
k track width	180mm
m Tipping bucket width	620mm
n Maximum Dumping Height	1700mm
P Maximum unloading tipper height	2980mm