

GODZILLA
LOADERS

Site Wizard

OPERATOR'S MANUAL



GODZILLALOADERS.COM.AU

To users and operators:

- Site Wizard Backhoe Loader is newly-developed product by may factory to adapt to the development of market economy and meet the damages of users, which can be applied to road construction, capital construction, mining, oil field and farmland and water conservancy construction, materiel loading, excavation of different construction foundation and pipe tunnel, etc. Now, we would like to analyze the economical efficiency and technical level of this product and put forward pricing suggestion and benefits to be obtained possibly.
- The design and development process of the Site Wizard Backhoe Loader aims at design level of same foreign model, the performance indexes of this machine reach or exceed the advanced level of the products of the same kind through adopting new technologies and computer optimization, so the this machine has high technical level and has the following characteristics:
- High-strength structure and performance as well as reliable hydraulic systems enable this complete machine to realize wide digging range, lifting and digging forces.
- The curved loadings movable arm and unique mechanism of connecting rod provide the complete machine with preferable loading distance and translational compatibility and enable the loading operations to be simpler and quicker, reducing the splash and falling of materials.
- The foundation support of the digging movable arm is wide and becomes narrower gradually, which expand the range of vision, the small- volume oil tank is fixed only with single pin, the line of sight of operators will not be affected when operating.
- Unique mechanism of connecting rod of bucket enables the bucket to rotate by 180°, which simplifies the digging operation of vertical arm.
- The selection and use of quick change couplers of work device make it possible to replace bucket and the other work devices quickly and easily without the use of any special pin shafts, tools or bucket.
- Four-wheel drive improves the tractive force further.
- Middle-position open type hydraulic system and heavy-duty tandem gear pump make the accurate measurement and portable and stable operation possible.
- The driver's cab is advanced in the same trade with its wide visual field for operation.
- Simple service and maintenance brings about great convenience for the user.

This manual main describes the operation, maintenance, service and correct use of the control devices of Site Wizard Backhoe Loader so as to keep the this machine under good operating condition.

This product is subject to improvement and enhancement, so please take notice that the contents described in this manual may be inconsistent with the product you purchases. Please consult the technical department and after-sales service department

of this factory upon any queries. When consulting, please let us know your model, number and date of leaving factory of complete machine to help up provide better service for you.

The complete machine shall be operated, maintained in accordance with the regulations and requirement indicated in this manual and made scheduled maintenance records.

This manual will be submitted to users with the machine.

This manual is compiled by the technical department of this factory; it will be highly appreciated if you can put forward your precious advices and suggestions for the errors, omissions and improvements. The technical department of this factory reserves the right of interpretation of this manual.

Please send your letters to technical department of this factory



- ① Front lamp / tail lamp: Driver's canopy or driver's cab is mounted with four front working /running lamps and four rear working lamps.
- ② Signal/warning lamp: Steering signal lamp and warning lamp mounted on top of driver's cab can also be used as flasher when traffic traveling.
- ③ outdoor rearview mirrors: which help driver to observe what happens behind.
- ④ Handrail: Handrail on reasonable position helps drivers to enter into or go out of driver's cab easily.
- ⑤ Lock of movable arm for loading: One kind of mechanical locks used to lock movable arm; movable arm can be locked with this lock when conducting maintenance and repair for machine or operating around machine.
- ⑥ Central articulated frame: which makes loading operations more convenient and turning radius maximize.
- ⑦ Hydrostatic transmission: Hydrostatic transmission system, save fuel and with good efficiency of environmental protection.
- ⑧ Oil filler and daily maintenance and check points which can be accessed standing on ground: Enable drivers to fill oil without climbing on vehicle.
- ⑨ Separate parking brake: Separate can be engaged immediately when engine stops running
- ⑩ Side-sliding frame: Side-sliding frame system expands digging range and widens application range.
- ⑪ Wide visual field: Driver's cab is designed to enable drivers to observe front-rear, left-right easily.

Table of contents

Safety instructions.....	1
Safety mark.....	9
Operating console	
Indicator lamp.....	12
Turning indicator lamp.....	12
Maneuver control.....	12
Loading operation control.....	12
Control lever for support leg.....	13
Control lever for digging operation-Two-lever control.....	13
Seat control.....	13
Vehicle lamp.....	14
Running- in of new automobile.....	15
Carefully observe running condition of engine.....	16
After running for 10hour or one day.....	16
Inspection during the first 50~100 hours—After-sales service inspection.....	16
Inspection before starting	
Inspection before daily starting.....	16
Operation of engine.....	16
Inspection of instruments before starting.....	17
Low-temperature warming-up.....	19
Engine stalling.....	19
Normal stop-- Manual transmission.....	19
Driving of Backhoe Loader	
Driving on road—Site Wizard.....	20
Forbid climbing or carrying vehicle.....	20
Vehicle driving-- Manual transmission.....	21
Running speed—Site Wizard (Manual gear-shifting transmission).....	21
Machine operation	
Preparation before digging.....	22
Operation of digging device.....	22
Operation of front loading device.....	23
Important points for operation.....	24
Operation with proper angle.....	24
Slope operation.....	24
Position of waste bank.....	25
Setting machine level.....	25
Moving machine with digging bucket.....	26
Operation of digging bucket.....	27
Using marking pole when ditching.....	27
Ditching operations.....	27
Role of loading bucket.....	27
Digging with loading bucket.....	28

Leveling and cleaning road surface.....	28
Digging earth bank or windrow.....	28
Refilling operations.....	29
Pit and ditch refilling operations.....	29
Truck loading.....	30
Terrace digging.....	30
Lifting operations.....	31
Transportation	
Loading and unloading Backhoe Loader with pallet truck.....	32
Tow truck.....	33
Fuel and lubricating oil.....	34
Diesel oil.....	34
Diesel oil storage.....	34
Diesel engine oil.....	35
Transmission and axle oil.....	35
Hydraulic oil.....	35
Lubricating grease.....	35
Optional and synthetic grease.....	36
Mixing action of lubricant.....	36
Scheduled maintenance	
Hanging “No operating” caution pate.....	36
Scheduled maintenance of machine.....	36
Avoiding earth accumulation.....	37
Using suitable fuel and lubricating oil.....	37
Preparation before maintenance.....	37
Lock for repairs and maintenance of loading movable arm.....	38
Switch for access door.....	38
Keeping system for maintenance and repair records.....	38
Keeping system for repair and maintenance records.....	40
Maintenance when necessary	
Belt inspection.....	41
Drain water and remove foreign matters in diesel oil tank.....	41
Checking tyre pressure.....	41
Charged pressure of tyre.....	42
Lock for repairs and maintenance of loading movable arm.....	42
Checking and cleaning hydraulic oil tank filter element.....	43
Scheduled maintenance—Each 10hours or daily maintenance.....	43
Checking engine oil level.....	43
Lubrication of articulated pin shaft of loading part.....	44
Lubricating support and oil cylinder.....	44
Lubrication of digging device.....	44
Weekly maintenance	
Lubricating (Front driving axle) universal joint of transmission shaft.....	44
Maintenance after operation of each 250h	

Checking oil level of driving axle.....	45
Checking batter for liquid level and pole plate.....	45
Checking hydraulic oil tank for oil level.....	46
Changing engine oil and filter.....	47
Checking wheel-side housing for oil level.....	48
Maintenance after operation of each 500h	
Checking air inlet hose.....	48
Replace oil filter of hydraulic system.....	48
Maintenance after operation of each 1000h	
Cleaning, assembling and adjusting front-wheel bearing--non-driving.....	48
Changing oil for axle box.....	49
Checking engine speed.....	49
Checking and adjusting connecting rod of engine speed control.....	50
Changing oil for transmission.....	50
Changing oil for hydraulic oil tank.....	51
Changing oil for wheel-side housing.....	51
Maintenance after operation of each 2000h	
Adjusting valve clearance of engine.....	51
Service and maintenance	
External inspection of brake.....	52
Checking air cleaner element.....	52
Removing dusts on cleaner element.....	52
Service and maintenance of cooling system.....	53
Checking radiator.....	53
Cooling liquid of diesel engine.....	54
Drainage interval of cooling liquid.....	54
Forbid maintaining oil nozzle.....	54
Forbid adjusting injection pump.....	55
Notes for operation of engine and voltage regulator.....	55
Careful maintenance of battery.....	55
Checking battery fluid for specific gravity.....	56
Using battery charger.....	56
Disassembling battery.....	57
Replacing fuse.....	57
Welding on vehicle.....	57
Checking machine for operating cycle time.....	57
Mounting cutting teeth of digging bucket.....	58
Service and maintenance instructions to fixed flanged joint of metric bolt.....	58
Checking hydraulic pipeline and joint.....	59
Maintenance instructions to seal joint at corner.....	59
Operational testing	
Inspection of braking system.....	61
Inspection of steering system.....	61
Inspection of hydraulic system.....	61

Checking operational condition of accessories.....	65
Checking parts and components in driver’s cab.....	66
Other inspections.....	69
Troubleshooting	
Analysis on failure in diagnostic list is from easy to difficult.....	70
Engine.....	71
Electrical system.....	76
Instrument and indicator lamp.....	79
Hydraulic system.....	80
Transmission.....	86
Front driving axle.....	88
Rear axle.....	88
Machine storage	
Preparation before machine storage.....	89
Monthly storage steps.....	89
Technical parameter	
Performance parameter of loading device.....	90
Performance parameter of digging device.....	90
Other information	
Lifting capacity of Site Wizard Backhoe Loader—Standard bucket arm.....	94

Safety instructions

(01-1)

Safety features:

- (1) Head lamp/tail lamp: Driver's cab is equipped with two working lamps/running lamps and two rear working lamps.
- (2) Signal: Direction signal lamp mounted on top of driver's cab can also be used as flasher when running.
- (3) Interior mirror: Which help driver to observe what happened behind.
- (4) Locking lever for losing movable arm: One kind of mechanical locking lever used to lock movable arm, the movable arm can be locked when conducting repairs or maintenance for machine or working around machine.
- (5) Handrail: Handrail on reasonable position helps drivers to enter into or go out of driver's cab easily.
- (6) Oil filler and daily maintenance and check points which can be accessed standing on ground: Which enable drivers to fill oil without climbing on vehicle.
- (7) Ladder: Wide and antiskid ladder can prevent from slipping down when going into or from driver's can.
- (8) Wide visual field: The driver's cab is designed to enable drivers to observe front-rear, left-right easily.

(01-2)

Comply with safety regulations

Read the instructions to safety marks in this manual and on machine carefully. Be familiar with correct operation of machine and operating devices to keep the machine under good conditions, forbid changing devices of machine to avoid affecting the performance and service life of machine.

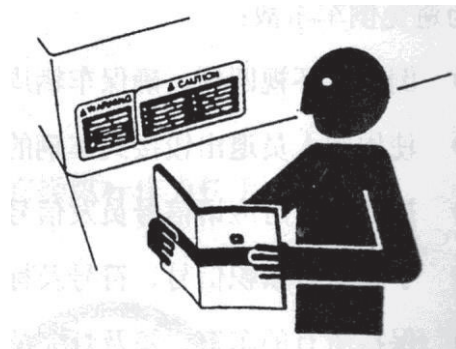

(01-3)

Avoid tipping over



In case of tipping over, it is forbidden to jump out from vehicle tipped over to avoid causing serious or mortal injury.

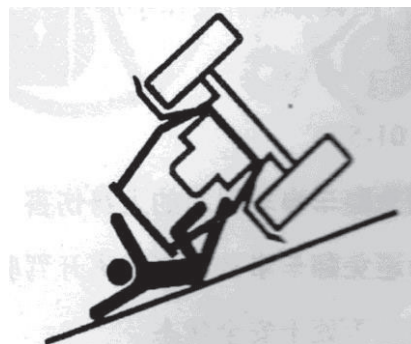

In order to avoid tipping over accident:

- Drive carefully on slope.

- Avoid turning sharply.
- Take notice of load balancing in bucket to have weight distributed equally to keep load stable.
- Make work devices close to ground to keep good line of sight and lower center of gravity.
- Throttle down firstly in case of load in work devices moves or turns.
- Take notice of load capacity of machine, forbid overloading.
- Extreme care shall be taken when digging, ditching or loading, unloading transport vehicles.
- Be familiar with operation instructions described in this manual.

(01-4)

Avoid accident caused by backing vehicle



Make sure there is no people around vehicle before moving vehicle!



Forbid people around enter into work area, warn people around by means of sounding the horn and sending other signals to people around before moving vehicle!



Assure that signalman to be always within range of visibility when sending signal by signalman and the signalman has backed to safe area before backing vehicle!

In order to avoid vehicle backing accident:

- Look around before backing vehicle to make sure all people around vehicle have backed to safe area.
- Let people around back off articulated area of articulated vehicle.
- Signal man shall be invited to send signal when the line of sight is blocked and assure that signal man is always within range of visibility.
- Understand meanings of all flag signals, symbols and marks and designate clearly responsible signal man.
- Keep all vehicle windows, mirrors and lamp complete and clean.
- Running speed shall be reduced and proper lamps shall be used under condition that line of view is affected by dusts, heavy rain or mist.
- Read and understand the operation instructions described in this manual.

(01-5)

Avoid personal injury due to vehicle-backing accident:

In order to avoid turning over accident, the vehicle shall be checked to be under safe state before leaving from driver's cab.



Avoid climbing or stopping runnind vehcel to avoid injury and fatal Accident!

In order to avoid turning over of vchile:

- Vehicle shall be stoped on level palce as far as possible.
- Keep proper distance with the other vehicel when stopping.
- Engage neutral gear for transmission when stopping.
- Set work devices on ground
- Shutdown engine.
- Pull up stopping brake handle to make it under braking state.
- If it necessary to stop the machine on ramp, place raising blocks under each wheel on downhill side.
- Read and understand the operation instructuins described in this manual.



(01-6)

Checking machine

Around areas shall be checked before starting engine daily (Please refer to inspection before starting).

(01-7)

Correct using handrail and ladder



Avoid injury caused by falling off from vechile:

When gotting on and down from vechile, catch hold of handrail and ladder, forbid using steering and other operating levers as handrails. Forbid jumping on and down from machine, forbid climbing up and down from running vechiel and interrupt vechiel moving.



Prevent vehicle moving from causing injury:

Forbid starting engine by means of shorting circuit. Machine can be starting only when driver is seating on driving seat and engaging neutral gear in transmission or engaging brake.



(01-8)

Safe driving

The revolving pin shaft is used to fixed the digging device on left end. If have to run on slope, set the digging device on uphill side to improve stability.

Carefully drive in one of the following cases:

- On slope.
- Work area is narrow.
- Uneven road surface or passing through road edge, rail.
- Run on edges of ditch and pit.

When running:

- Ensure the brake pedal has been connected well.
- Lower loading bucket.
- Engage gear to run.

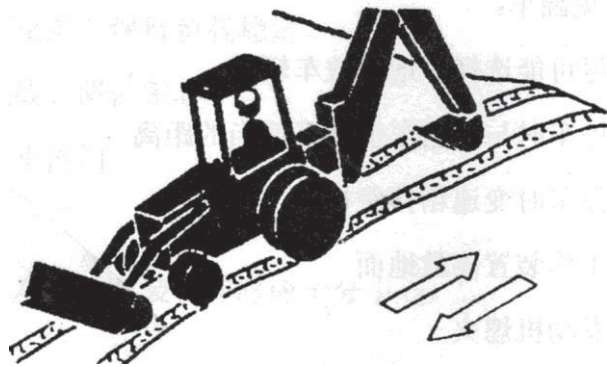

Safe driving:

See positions where the people are standing clearly before moving vehicle. Signal man shall be invited to send running signals, the hand signals send by signal man shall be referenced before starting vehicle.



(01-9)

Safe digging operations

The positions of cable, gas and water pipes shall be checked firstly before digging operations.

In order to avoid inexpectedly moving of vehicle, before turning seats and operationg digging devices:

- Lower support leg to make rear wheel remain away from ground slightly.
- Lower loading bucket onto ground (tip frontwards under possible condition).
- Engage neutral gear for transmission.
- Engage stopping brake.

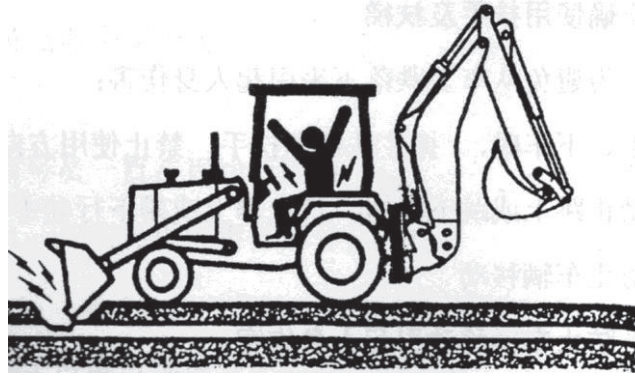

The machine moving can be carried out by experienced operator by the use of digging bucket on level road surface. Otherwise, operator shall seat on position for loading operations to lift loading bucket and support leg and drive machine to move it. The support leg shall be put down again after moving machine, which shall be supported by solid road surface, wood plate or other hard boards shall be placed under support legs. Take notice that the machine may move when lifting support legs and loading bucket.

When conducting operations on slope, avoid swinging bucket to direction of fall, unload to direction of upslope under possible conditions. Movable arm shall be moved slowly when lifting load bucket to maximum position. People around shall back off work area and move area of machine when conducting operations.

Keep away wires:

Keep away from wires to avoid serious injury or death accidents. Any parts or loads of machine shall not be less than 3m+2times of insulated length of wires.



(01-10)

Take notice of harm of tail gas to human bodies.

Good ventilation shall be kept if have to carry out operation indoor. Extended exhaust pipe can be used to reduce tail-gas emissions or open windows to increase air circulation.



Forbid others climbing vehicle and being carried by vehicle

This vehicle can only be driven by driver, it is strictly forbidden for others to climb or be carried by it. The people climbing or transported by the vehicle may fall to the under of vehicle due to collision caused by foreign matters. The others climbing or be transported by vehicle may block the line of view of driver, leading to unsafe driving state.

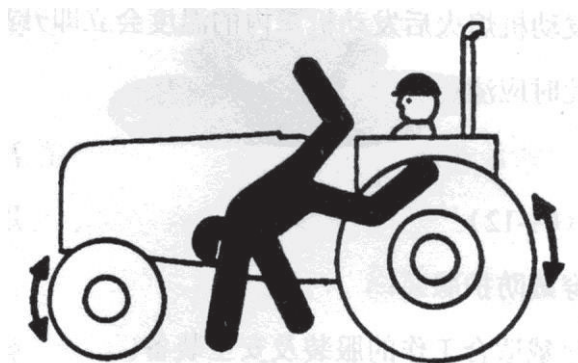

Pay attention to fire protection when filling fuel

Fuel is inflammable; therefore, no smoking and keep away from fire source or spark when filling fuel.

Engine shall be shutdown before filling fuel and fill fuel outdoor.

Take notice of removing waste materials, lubricating oil and fragments accumulated on vehicle to avoid causing fire. Fuel spilling out shall be removed timely.



(01-11)

Emergency preparation

First aid box and fire extinguisher shall be prepared at hand.

Telephone numbers of doctors, ambulance service and hospital as well as fire department shall be recorded on the side of telephone set.

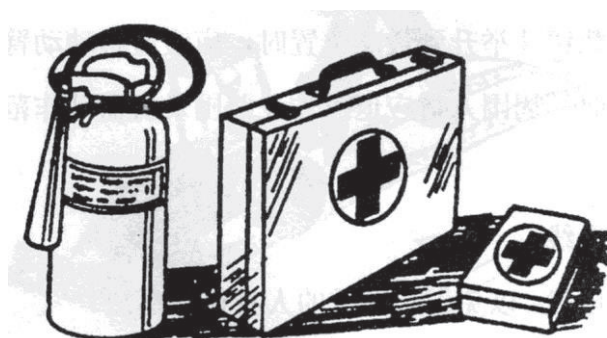

Safe using starting liquid:

Starting liquid is combustible material.

Keep away from fire source or spark when using starting liquid. Keep starting liquid away from battery and cable.

The opening of pressure can used to store starting liquid shall be covered with cover and pressure can shall be placed at cool and safe position.

Forbid burning or perforating starting liquid can.

Remove water materials accumulated on machine:

Keep inside of engine cover, radiator, battery, hydraulic pipeline and fuel tanks as well as driver's seat clean.

Temperature in engine cover will rise immediately after shutdown engine; here, pay attention to fire prevention.

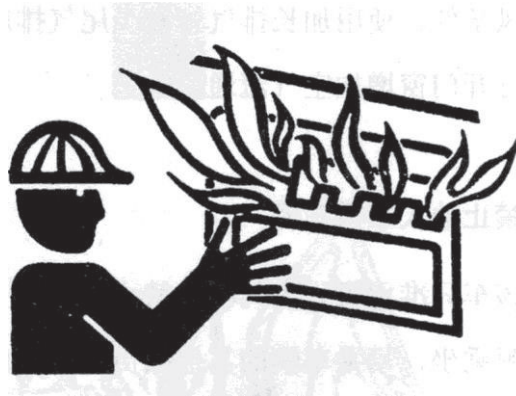

(01-12)

Wear protective clothing:

Wear clothing or safety arrangement suitable to work.

In order to concentrate on machine operation, driver shall not take with or wear radio or earphone when working.

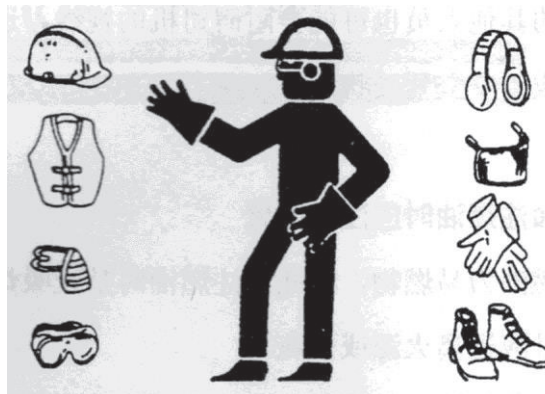

(01-13)

Use safety lamp and safety device:

Install and operate safety lamps and safety devices required by operations, and protect above safety facilities carefully and replace immediately if damaged or lost.

- A lamp
- B Fog sign

(01-14)

Remind others of maintenance and repairs are conducting:

When repairing machine, personal injury even death may be caused if machine moves accidentally.

Warning plate “No operating” shall be hung on steering wheel before conducting repairs and maintenance to machine to remind the others.

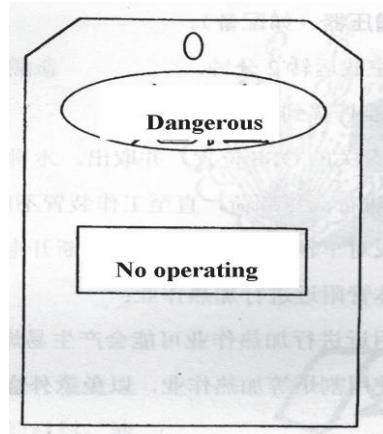

(01-15)

If have to conduct maintenance to machine when its running, the machine shall be taken care by the other during maintenance process to avoid machine moving unexpectedly.

All parts shall be kept under good working conditions and assembled properly. Repair immediately if parts and components are damaged, replace worn or broken parts and components; remove oily soil or debris accumulated timely. Be familiar with repairs and maintenance steps and have repair field kept clean and dry before conducting repairs and maintenance.

During the repairs and maintenance process, all parts and components shall be locked with locking lever of movable arm for loading and locking lever of movable arm for loading, or lower work devices onto ground to avoid moving during repairs and maintenance process.

Forbid repairing or lubricating machine when it is operating. Keep hands, legs and clothes away from moving parts.

The followings shall be done before repairing machine or leaving driver's cab:

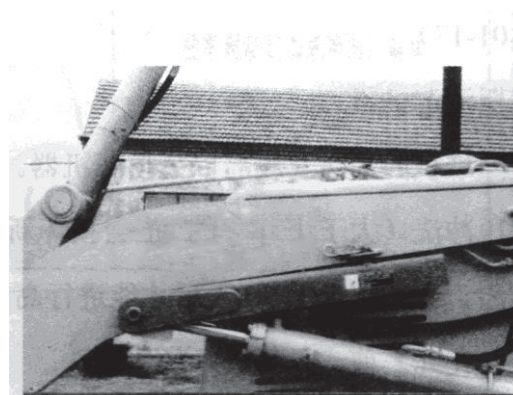

1. Stop vehicle on level road surface.
2. Lower work devices onto ground.
3. Set speed-changing and steering lever on working positions.
4. Engage parking brake.

Important instructions: The turbocharger (if equipped) of engine may be damaged if fails to shutdown the engine in accordance with normal steps.

5. Run for 2 min at 1/2 speed under no load.
6. Move hand throttle control lever to idle position.
7. Turn key to OFF position of switch and take it out.
8. Move control lever to unload at high pressure till work device cannot move.

Disconnect earthing cable of battery before regulating electrical system or welding and repairing machine.

Avoid conducting heating operations near the high-pressure fluid pipes.

If conducts heating operation near high-pressure fluid pipes, inflammable substance may splash around and cause fire. Forbid welding or heating with the use of cutting torch, etc to avoid burning out high-pressure fluid pipes.

(01-16)

Avoid injury caused by high-pressure fluid pipe:

The high-pressure liquid flowing out at high pressure will thorn damage skin and cause serious injury.

Pressure shall be released before cutting off pressure and the other pipelines. All joints shall be tightened before applying pressure.

The leaking place shall be checked with paper board to avoid hands and body from harming by high-pressure liquid.



If accident of thorning damage by high-pressure liquid happens, please take medical treatment immediately, all harmful liquid shall be removed as quick as possible to avoid corroding.

(01-17)

Clean machine regularly:

Remove oily soil and sweepings accumulated to avoid damaging machine.

High-pressure rinse (About 1379kPa) will damage newly-coated finish coat. As for new

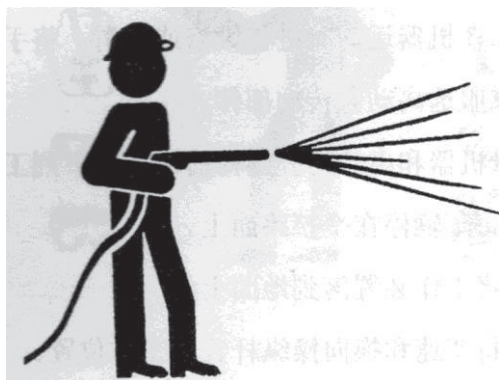

vehicle, high-pressure rinse can be conducted after 30 days of air drying, only low-pressure can be conducted before this.

Cannot spray on radiator fin from any angles to avoid bending radiator fin.

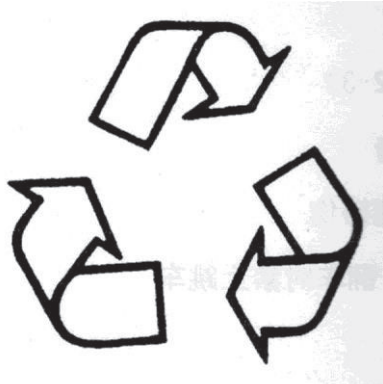
<p>Cooling system:</p> <p>High-temperature cooling liquid spouted from cooling system may cause serious scald.</p> <p>Shutdown engine and cool for certain period of time, then screw off water tank by one turn and take off till pressure released.</p>	
<p>(01-18)</p> <p>Dispose of waste materials properly:</p> <p>Improper disposal of waste materials may cause serious harm to natural and ecological environment. This machine adopts the following materials with potential harm: hydraulic oil, fuel, cooling liquid, brake fluid, filter and battery, etc. when it is necessary to drain oil or other liquid, leakproof container shall be used, forbid using food or beverage containers to avoid misguide the others to drink.</p>	

Forbid draining waster materials onto ground, into drainage ditch or any water sources.

Air-conditioner refrigerant drained into air will damage earth aerosphere. The used refrigerant shall be disposed through designated waste recovery department in accordance with government regulations.

Waster materials shall be disposed of properly according to local environment and regulations of waste recovery center.

Safety mark

(02-1)

Danger

Engaging brake or control lever is on mid position, start machine when seating on driver's seat.

Start with neutral gear

Note

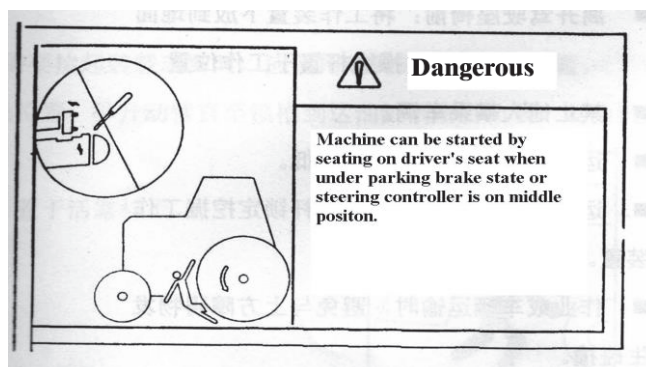

Please do not open under high pressure and high temperature.
Take off slowly

(02-2)

Warning

Avoid serious injury

Use wedge block to support vehicle wheels to avoid vehicle moving forwards after disengaging parking brake.

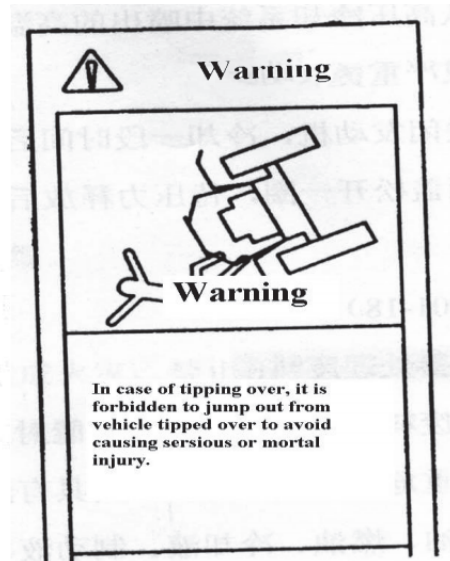
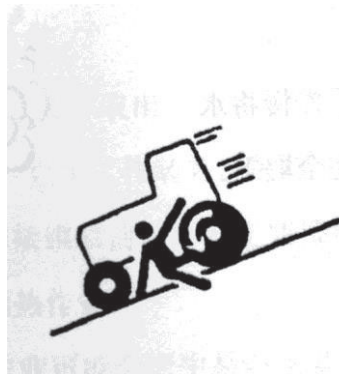

(02-3)

Warning

Avoid injury caused by squeeze

- Forbid jumping down from vehicle when turning over

(02-4)

Note

- In order to avoid injury and fatal accident during operating process, the operation instructions shall be read carefully before operating.
- Operate only when seating on driver's seat.
- Before leaving driver's seat: Lay down work devices on ground.
Set operating lever on working position.
- Forbid others climbing up vehicle and carrying by vehicle.
- Lower work device when on transport position.
- Work device for digging shall be locked with locking lever of digging arm before transporting.
- Avoid colliding with upper obstacles when operating or vehicle transporting.

(02-5)

Warning:

In order to avoid personal injury, driver can only operate seating on driver's seat. Ensure there is no others entering into work area.

(02-6)

Warning:

Avoid causing injury by draining high-pressure oil.

Generally, the hydraulic operating lever shall be moved to release pressure firstly before disassembling hydraulic pipelines.

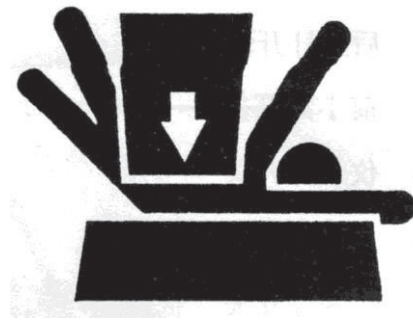

(02-7)

Protect eyes

Gas sputtering or discharging may harm your eyes or blind you.

Forbid;

- Spark
- Fire source
- Smoking

(02-8)

Warning:

Movable arm shall be locked with locking lever of movable arm when it is necessary lift movable arm for loading when repairing machine or working around machine.

- Empty bucket and place it on unloading position, lift movable arm till lock groove reaches position of cylinder piston rod, engine stops running.
- Pull out pin shaft, place locking lever of movable arm on piston rod.
- Lower movable arm till lock slowly.



Operating console

(03-1)

This chapter mainly introduces the meanings of different indicator lamps, switches and instruments, while the auxiliary starting button and key switch will be introduces in the chapter of engine.

- A. Switch for rear head lamp
- B. Switch for front small light
- C. Switch for instrument light
- D. Switch for rear small light
- E. Switch for fog lamp
- F. Switch for front head lamp

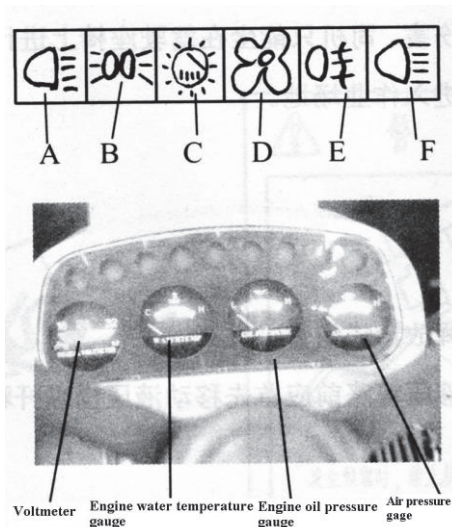

(03-2)

Indicator lamp

This chapter will introduce the meanings of different indicator lamps, switches and instruments in detail.

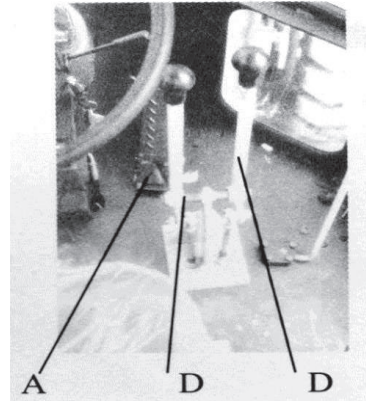

(03-3)

Turning indicator lamp

When dialing the turning indicator lamp, it lights.

(03-4)

Operational control

The vehicle can be controlled through operating lever. (Please refer to driving section for details)

- A. Gear shift control rod
- B. Brake pedal for throttle
- C. Brake pedal

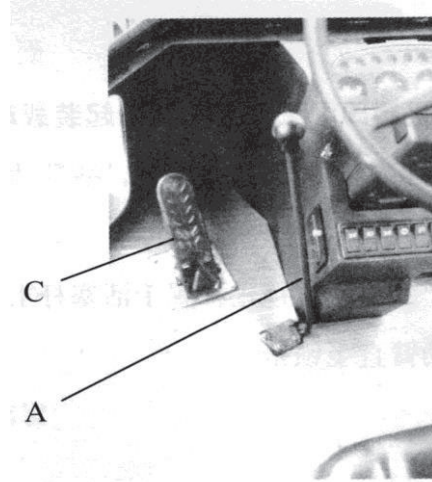

(03-5)

Loading operation control

- D. The loading section of this machine can be controlled through

(03-6)

Use control lever to control digging device.

- A. Movable arm and turning control levers
- B. Bucket arm and digging bucket control levers

(03-7)

Control lever for digging operations- Double-rod control

Use control lever to control digging device. (Please refer to detailed instructions in chapter of machine operation)

Warning: This machine can be equipped with multi-types of control levers for digging operations, therefore, its operation control type shall be identified firstly before operating.

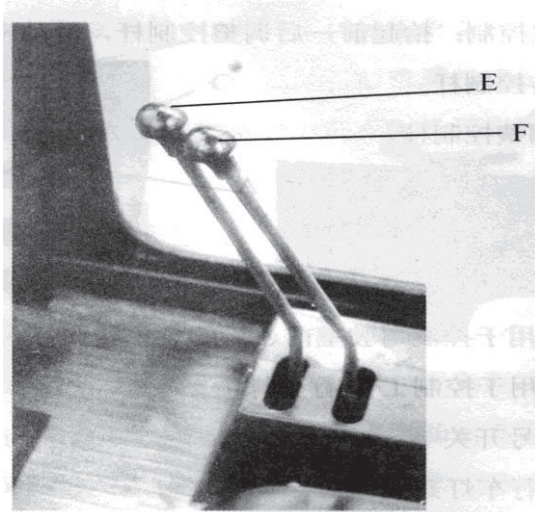

In order to avoid personal injury caused by accidental movement of machine, it is only allowed the driver to operate work device for digging operations after seating on driver's seat, turning seat to digging device and laying down support leg.

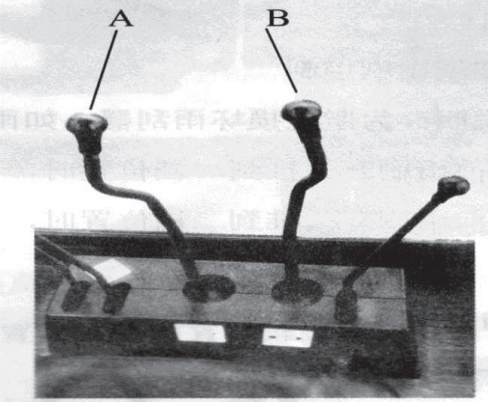
<p>A. Bucket arm and turning operating levers B. Movable arm and bucket control levers</p> <p>(03-8) Seat control Warning: Before operating, check whether the seat is on locking position. If the seat is locked improperly, this may result in misoperation and causing accidents.</p>	
--	--

Turning control: Release control lever after lifting control lever and turning seat to lock seat.

Front-rear adjustment control: Release control lever after lifting front-rear adjustment control levers and sliding seat to desired position.

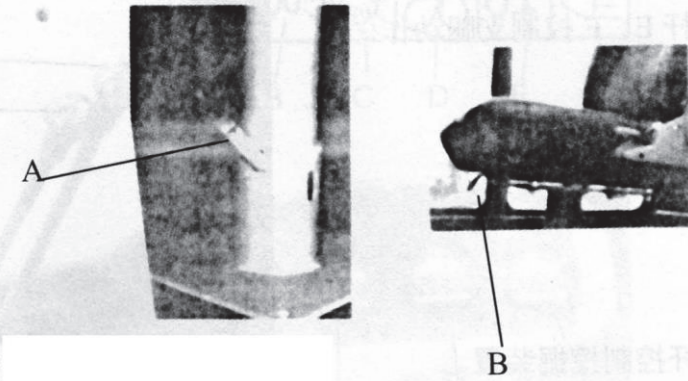
<p>A. Seat turning control B. Front-rear adjustment control levers</p> <p>(03-9) Vehicle lamp Switch (A) is used to control front and rear yellow steering lamps of driver's seat. Switch (B) is used to control working /running lamp.</p>	
--	--

- A. Switches for turning signal lamp
- B. Switches for working and running lamps

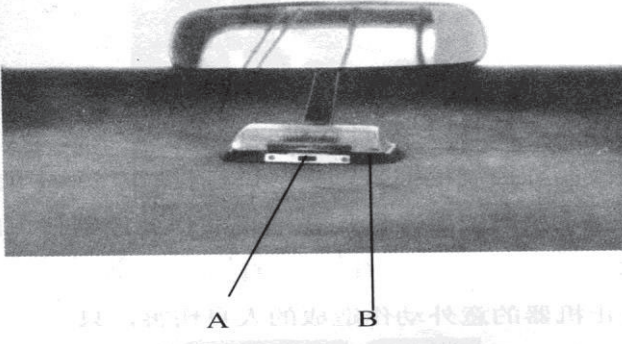
<p>(03-10) Canopy lamp Switch (A) is used to control ceiling lamp (B).</p> <ul style="list-style-type: none"> A. Switch for ceiling lamp B. Ceiling lamp <p>(03-11)</p>	
--	--

Windshield wiper control

Important instruction: In order to avoid damaging rain wiper, it is forbidden to operate rain wiper when it is frozen on glass.

1. When pushing wiper switch to Gear I position, wiper will move slowly.
2. When pushing wiper switch to Gear II position, wiper will move quickly.

(03-12)

Side window- emergency exit

The side window can be opened by 180°, so that it can be used as emergency exit.

Pull handle (A) inwards to help it depart from locking post to open side window.

Insert button (B) into locking groove (C) to fix the opened wide window on fixing glass on the same side to avoid swinging back and forth of vehicle windows.

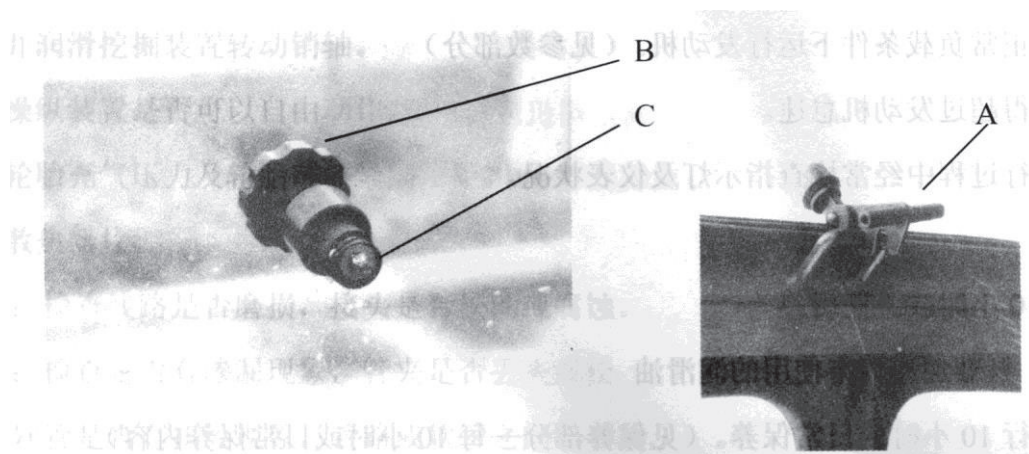

(03-13)

Rear vehicle window

When opening vehicle window, depress lock pin (A), unlock window lock and lower vehicle window.

When closing vehicle window, depress lock pin and lift vehicle window until support upper vehicle window, depress both sides on top of vehicle window to lock vehicle window.

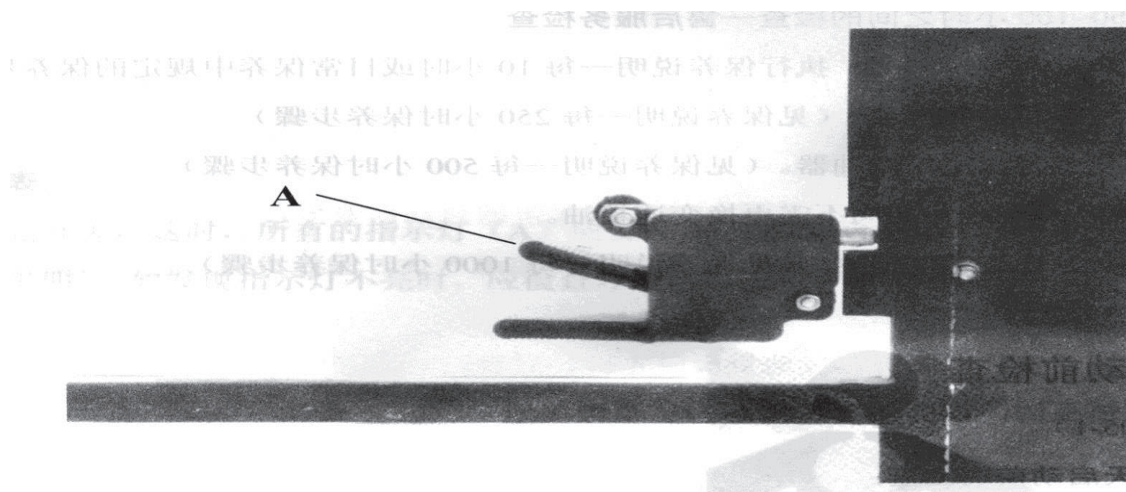

Running in of new vehicle

(04-1)

Carefully observe operating condition of engine.

Important instruction: Be familiar with and understand operating sound and operational feeling of new machine.

Engine is filled with lubricating oil. Seasonal viscous oil shall be added if it is necessary to fill oil. (Please refer to the section of fuel and lubricating oil)

1. Run engine under normal loading condition. (Please refer to the section of parameter).
2. The idle speed of engine shall not be exceeded.
3. The operating conditions of indicator lamps and instruments shall be checked frequently.

After operating for 10h or one day

Note: Only approved lubricating oil is allowed to add.

1. Carry out each-10-hour or daily maintenance. (Please refer to maintenance section-each-10-operating hour or daily maintenance contents)
2. Check cooling liquid level, engine oil level, transmission oil level and hydraulic oil level.
3. Check for leakage.
4. Check different parts for tightening torques, tighten if necessary. (Please refer to regulations on tightening torque of relevant part).

(04-2)

Inspection during the first 50~100 hours—After-sales service inspection

1. When schedule time is coming, execute maintenance instruction-Maintenance steps specified in each-10-operating hour or daily maintenance.
2. Replace engine oil filter. (Please refer to maintenance instructions-Maintenance steps for each operating hours of 250 hours)
3. Replace oil filter in hydraulic system. (Please refer to maintenance instructions- Maintenance steps for each operating hours of 500 hours)
4. Replace oil filter of transmission. (Please refer to maintenance instructions-Maintenance steps for each operating hours of 1000 hours)

Inspection before starting

(05-1)

Scheduled maintenance and service shall be carried out according to regulations on each-10-operating hour or daily maintenance.

Check and lubricate turning pin shafts of loading device and digging device.

Check engine oil level.

Check coarse filter.

Check hydraulic oil level.

Clean driver's cab.

Check and lubricate turning pin shafts of digging device.
Check whether operating device can move freely.
Check tyre charging pressure and tightening torque of tyre parts.
Clean radiator fins.

Electrical system: Check whether wires have been worn and joints have been loosened and corroded.

Hydraulic system: Check for seepage and leakage and pipe clamps have been lost or loosened. Check the hydraulic hoses for twisting and check for mutual friction between pipeline and hoses and with other parts.

Work devices for digging and loading: Check for loosened, bent, broken or lost parts and components.

Lubrication: Check lubrication points specified in “scheduled maintenance table” or “Each-10 operating hour or daily maintenance”.



Check around areas of machine, ensure there is no people within working area of machine.

Operation of engine

(06-1)

Inspection of instruments before starting

Turn key switch clockwise, here, all indicator lamps (A) shall light. (Please refer to instruction of positions and meanings of indicator lamps in section of operating console). If find indicator lamps do not light, check whether bulbs have been damaged. If bulbs are under good conditions, consult your local dealer.

(06-2)

Start engine

Warning: Take notice of harm of tail gas to human bodies.

Good ventilation shall be kept if have to carry out operation indoor. Extended exhaust pipe can be used to reduce tail-gas emissions or open windows to increase air circulation.

Prevent movement of vehicle from causing personal injury. Forbid starting engine by means of shorting circuit. The machine shall be starting by engaging gear if do not use normal starting circuits.



Forbid starting machine standing on ground. Before starting, driver shall seat on driver's seat, and set control rods for advancing and backing to middle positions and engage parking brake.

1. Seat on driver's seat.
2. Sound the horn.

(06-3)



Note: Set operating lever and switch on specified position before starting engine!

3. Set gear shift control rod and control rods for advancing and backing to middle positions.

Important instruction: In order to avoid damaging machine, each starting time shall not exceed 30 seconds. If engine cannot be started, the engine shall be started after waiting for at least 2 minutes. If still fails to start engine after starting for 4 times, please refer to troubleshooting table to search for causes of failures.

(06-4)

Use battery (24V system)

Before starting, machine shall be stopped and braked safely to prevent machine from accidental moving after starting.

Warning: When using or charging battery, one kind of explosive gas will be generated; therefore, keep battery away from fire source or spark. The battery shall be charged within area under good ventilating condition.

When assembling and disassembling battery, the negative pole earthed shall be disassembled firstly and assembled later.

Important instruction: The electrical system of this machine is 24V minus earth.

(06-5)



Important instruction: In order to ensure full lubrication, run engine at 1/3 engine speed for 5 minutes under no load. When temperature is below 0°C, extend idle running time properly.

Run engine at 1/3 engine speed for 30 seconds before machine is running.



Important instruction: In order to prevent from carbon accumulation in engine and ensure economical use of oil and forbid engine running at low rotating speed under no load.

Forbid engine running at high speed or low speed under no load.

After warming up engine, run machine for 5 minutes under light load.

Frequently check condition of instruments.

(06-6)

Low-temperature warming-up



Important instruction: Low-temperature hydraulic oil make the hydraulic system exert slowly; therefore, the machine can be operated only when cycling time of movement of hydraulic system is close to normal cycling time.

The warmup time shall be extended under the condition that environment temperature is very low.

The hydraulic system can be operated after machine has been warmed up fully. Before operating machine, ice, snow and dirt accumulated on machine shall be removed firstly.

1. Run engine at 1/2 engine speed for 15 minutes.
2. Lift movable arm to height of engine cover and move bucket within limiting position for 3 times.
3. Circularly perform the other hydraulic function to distribute warmup hydraulic oil, until all function can be performed freely.

Engine stalling

Important instruction: When operating under load, overheating generated by engine stalling can damage engine.

Hot starting of engine: Discharge load immediately, restart engine. Run engine at 1/3 of rated speed for 30 second under no load, then increase load and restore operation. After restarting engine stalling, if it is necessary to shutdown, the instruction in this chapter about normal stop shall be followed.

(06-7)

Normal stop-- Manual transmission

Important instruction: It is necessary to run at 1/3 of rated speed for 1~2 minutes under no load to cool parts giving out heat if need to stop engine running under working load. When stalling occurs to engine under load condition, the engine shall be stopped immediately and restarted then, run the engine at 1/3 of rated speed for 1~2 minutes to make cooling liquid continue circulating in engine.

1. Stop machine on level road surface.
2. Lower work device onto ground.
3. Set gear shift control rod , forward and backward control rods on moving positions.



Warning: In order to avoid unexpected moving of machine, the parking brake shall be engaged.

4. Run engine at 1/3 of rated speed for 1~2 minutes under no load.
5. Set operating lever of engine speed on slow-speed idle position.
6. Turn key to deenergizing position of engine.

7. Move control lever to release pressure till work device cannot move any more.

Operation of loaderdigger

(07-1)

Driving on road—Site Wizard loaderdigger

Be familiar with local laws and regulations relating to road driving. Ensure slow-speed traveling mark, vehicle mirrors, vehicle lamps and reflecting mirrors under good conditions and with normal functions.

Before driving:

1. Retract digging bucket and bucket arm.
2. Lift movable arm for digging move sliding frame to position of left end. Install locking lever of digging arm.
3. Lift the support leg.
4. Turn seat to forward position.
5. Lift loading bucket from ground and retract bucket.

(07-2)

Forbid climbing or carrying vehicle

Warning: This vehicle can only be driven by driver, it is strictly forbidden for others to climb or be carried by it. The people climbing or transported by the vehicle may fall to the under of vehicle due to collision caused by foreign matters. The others climbing or be transported by vehicle may block the line of view of driver, leading to unsafe driving state.



(07-3)

Vehicle driving-- Manual transmission



Warning: Avoid personal injury caused by accidental movement of machine

1. Set engine speed control lever on desired position then restart engine. (Please refer to the contents relating to the startign of eninge in chapter of oerpatation).



Warning: In order to prevent machine from accidental moving after stopping vehicle, set the forward and backward control rod s on traveling or backing position and engage parking brake.

1. Change running direction through forward and backward control rod s.

- Slow down firstly before changing running direction.
- If set forward and backward control rods on forward position, vehicle runs forwards; If set forward and backward control rods on backward position, vehicle runs backwards.
- After stopping, set forward and backward control rods on forward or backward position. Engage parking brake.

(07-4)

Running speed—Site Wizard (Manual gear-shifting transmission)

When assembling 16/70-20 standard tires, the running speed of vehicle as follows:

Forward		Backward	
Gear I	Gear II	Gear I	Gear II
6.66km/h	20 km/h	6.66km/h	20km/h

(07-5)

Stopping-Manual transmission

1. Stop vehicle on level ground.
2. Lower loading device onto ground.
3. Set the gear shift control rod on middle position and forward and backward control rods on forward or backward position.
4. Operate control lever to set engine speed at position of 1/2 speed and run for 2 minutes.
5. Set engine speed on low-speed and idle position.
6. Set key switch on OFF position and take out key.
7. Move control lever to release hydraulic pressure till work device does not move any more.

Machine operation

(08-1)

Preparation before digging operations:

1. Machine is running backwards till close to digging position, stop vehicle on level ground.
2. Set forward and backward control rods and gear shift control rod on middle positions.
3. Lower bucket of loader on ground then continue lowering movable arm till front tires leave from ground.
4. Turn seat to digging device.
5. Lower the support leg till rear wheel lifts from ground slightly. (Please refer to operation instruction of support leg).
6. Check whether moving clearance of control rods for digging is proper or not.

(08-2)

Operation of digging device



Warning: In order to prevent unexpected starting of machine from causing personal injury, the support leg shall support on solid ground. When lifting support leg and bucket, take notice that machine is likely to move. Before operating digging device, lift and set the machine level by the use of support leg.

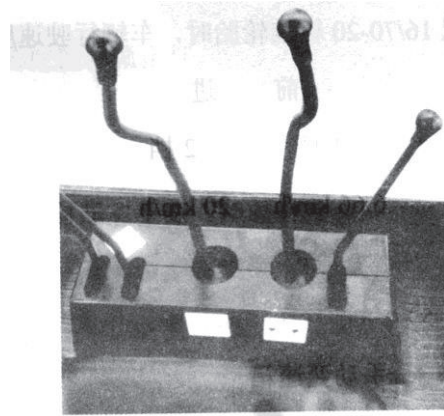

(08-3)

Operation of digging device

In order to prevent unexpected starting of machine from causing personal injury, the digging device can be operated only after driver seating on driver's seat, turning seat to digging device and laying support leg down.

Operate digging device through control lever. Set digging parts to prescribed direction as specified.

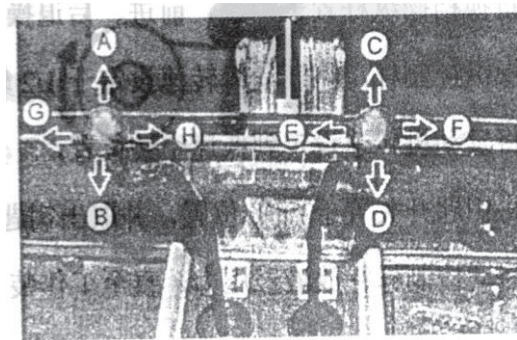

In order to increase operational cycling time, push operating lever to desired direction completely when moving and operating one more parts.

Transporting/storing position of digging device:

1. Move sliding frame to left side, retract bucket and bucket arm, big arm is close to vehicle frame.
2. Install lock pin of big arm.
3. Lift the support leg.
4. Turn seat to make it face forwards.
5. Load of receiving bucket of bucket till bottom of bucket level with ground.

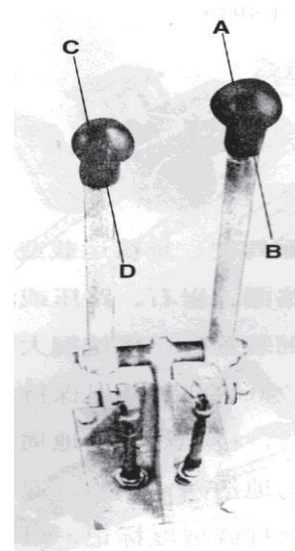

(08-4)

Operation of front loading device



Warning: In order to prevent unexpected starting of machine from causing personal injury, seat shall face forwards and driver shall seat on driver's seat when operating loading device.

Push operating lever at direction shown in figure to realize corresponding action.



Note: Push operating lever forwards to limiting position (A) to keep work device on floating position. Move control lever manually forwards, the work device will always keep on floating position.

- A- Push control lever forwards, movable arm will lower.
- B- Pull control lever backwards, movable arm will raise.



Note: After moving operating lever leftwards to limiting position (receiving bucket), control lever will keep on this position till set bucket level. After setting bucket level, control lever returns to middle position.

- C- Push control lever forwards, bucket will retract.
- D- Pull control lever backwards, bucket will unload.

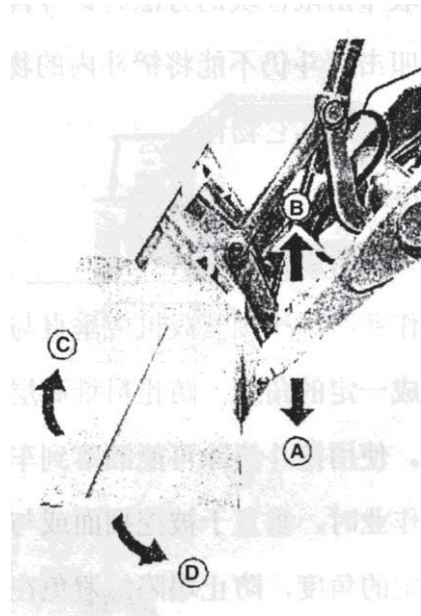

In order to increase operational cycling time, push operating lever to desired direction completely when moving and operating one more parts. Run engine at high speed under no load and move movable arm and bucket at the same time.

- A- Movable arm drops
- B- Movable arm lifts
- C- Bucket retracts

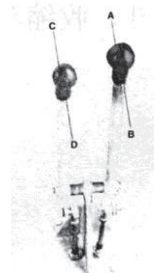

- D- Bucket unloads

(08-5)

Important points for operation

When driving on uneven road surface or transporting under heavy load or operating in crowded area, shall slow down to run at low speed to improve capacity of controller. Avoid running on uneven road surface, rock, ditch, etc.

When do not use digging device, lift big digging arm to full-lifting position. Turn over bucket downwards and retract extension bucket arm.

When traveling, lower loading bucket to keep good line of sight and vehicle stability.

Before beginning of operation, check the around area of operational field and eliminate risk factors.

Keep the operational field clean, level and keep optimum stability of vehicle.

Avoid knocking down the marking pole or grade mark to avoid losing visual reference substance to lead to repeated work.

Loose, fragmented materials are easy to unload. In order to break materials into pieces during loading materials into bucket to avoid cohering, the thin-layer digging method shall be adopted.

If unload materials in bucket completely by means of knocking stop block, smallest knocking force shall be ensured to damaging oil cylinder. If fails to unload materials completely by means of knocking bucket, the bucket can be cleaned up manually, forbid hitting bucket against on ground or other objects when unloading.

(08-6)

Operation with proper angle

When loading, loaderdigger shall be perpendicular to angle forming between material piles to avoid higher-layer materials of material pile collapsing on vehicle. Digging bucket can be used to get rid of materials splashing and falling on vehicle. When digging, perpendicular to digged surface or form certain angle with digged surface to avoid collapsing. Avoid operating on edges of ditch or adit, etc.

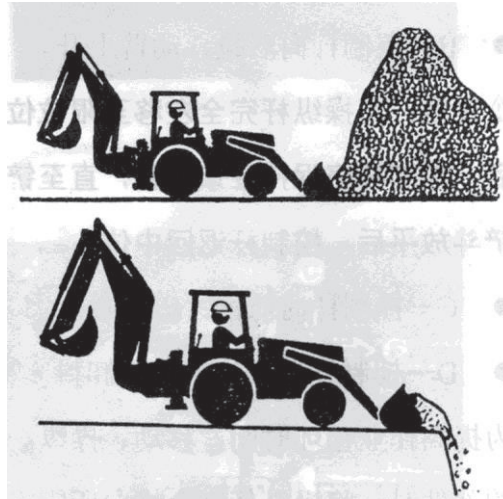

Use digging bucket to fill up subsidence area.

Slope operation



Warning: Forbid turning on slope to prevent from causing personal injury caused by turning over accidents.

When running up or down from slope directly, bucket and digging shall touch

ground, retract bucket arm.

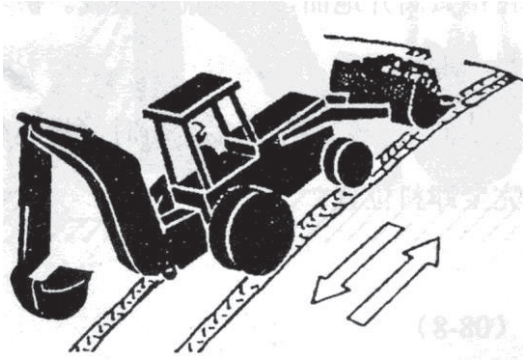
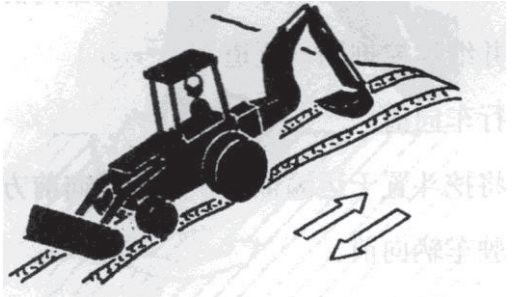
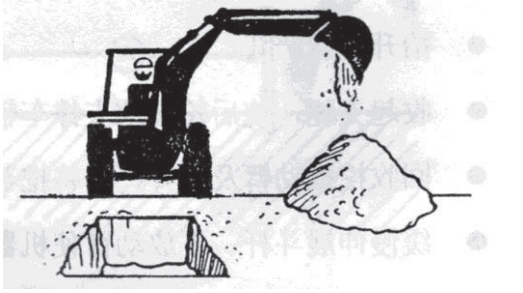
<p>When loading bucket is under load:</p> <ul style="list-style-type: none">● Set bucket level or retract it slightly.● Retract bucket completely when running down from slope. <p>When loading bucket is under no load:</p> <ul style="list-style-type: none">● Set bucket level when running on slope and lift bucket to certain height to avoid spudding in ground of bucket.● Bucket shall face to direction of fall and drive slowly.	 <p>The illustration shows a loader on a downward slope. The bucket is held level, and the loader is moving down the slope. Two white arrows point downwards along the slope, indicating the direction of travel. The loader's bucket is positioned to avoid digging into the ground.</p>
<p>(08-7)</p> <p>Position of earth deposit</p> <p>To avoid collapsing, set waste bank on position away from 1m of edge of pit. When excavating deep excavation, the distance from earth deposit to pit shall be increase because the volume of earth deposit is very huge. Set earth deposit on convenient position so as to transport and refill with truck easily.</p> <p>When operating on slope, set earth deposit on upslope to improve stability so as to refill easily.</p>	 <p>The illustration shows a loader on a downward slope. The bucket is raised and dumping earth onto the upslope side of the pit. Two white arrows point downwards along the slope, indicating the direction of travel.</p>
<p>Place machine level</p> <p>When digging, stop machine on solid and level ground.</p> <ol style="list-style-type: none">1. Level operational field if necessary. <p>Important instruction: In order to avoid causing personal injury because of turning over and unexpected movement of vehicle, forbid shoveling or digging ground under support leg.</p>	 <p>The illustration shows a loader on a level ground surface. The bucket is raised and dumping earth into a pit. The loader is positioned on a solid, level surface.</p>

Note: When lowering support to place machine level, extension length of both support may be different due to the difference in height of ground.

2. Lower support leg to place machine level and keep stable between both sides, lift rear wheel from ground slightly and remove load on rear wheel.
3. Set loading bucket on digging position and lower movable arm till front

wheel leave from ground slightly, remove load on front wheel. Add materials into bucket to increase balance weight.

When ground is covered by ice, wet or rocky, set loading bucket on full unloading position.

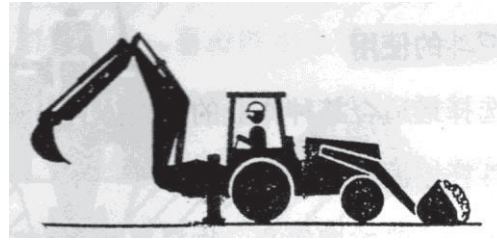

(08-8)

Move machine with digging bucket

Move machine forwards by one of the following means and continue digging the same pit.

Running forwards.

Set bucket on transporting position, turn seat to front, drive vehicle to run forwards.

Move machine with digging bucket:

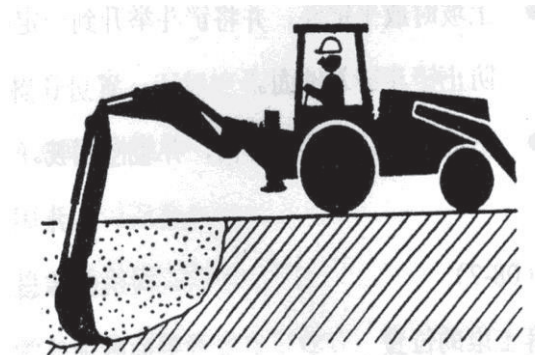
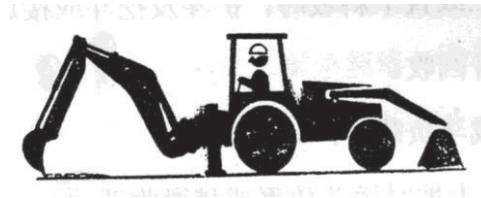

Note: Machine shall be operated by experienced driver when selecting to move machine with digging bucket.

- Turn bucket to middle position, check the front area of vehicle for others.
- Set gear shift control rod and forward and backward control rods on middle positions.
- Lift loading bucket.
- Retract support leg and lower rear wheel to ground to support rear weight of vehicle.
- Retract digging arm and bucket arm and insert digging bucket ground tightly.
- Extend bucket arm slowly and lower movable arm to move machine forwards.
- After machine moving to desired position, lower support leg and loading bucket to place machine level, and then continue digging operations.

(08-9)

Operation of digging bucket

Select digging method suitable to certain operations.

Bucket arm digging:

Used to general digging operations, materials leveling and ditching operations.

The bucket arm digging completes most action by the use of bucket arm cylinder.

1. Set bucket arm on vertical position firstly then move it away from complete machine by 0.61m.
2. Retract bucket arm and turn bucket to complete first digging. Digging length and depth of the first digging are 1.2m and 75~100mm respectively.
3. Repeat steps 1 and 2 then continue digging and increase digging depth to 100~150mm.

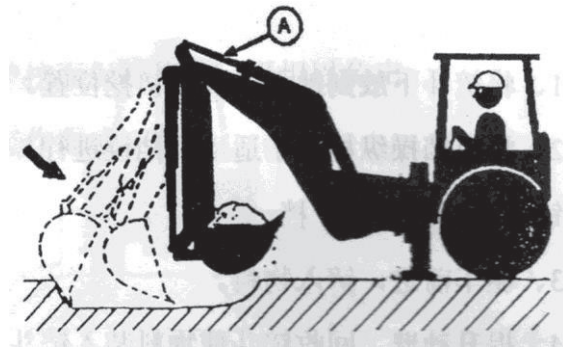

Bucket digging:

The oil cylinder for bucket can be used to dig, when big-power digging is necessary or when operating on narrow area.

1. Lower the extended bucket onto ground of digging area and lower movable arm to insert bucket into ground.
2. Turn bucket till bucket is willed with materials while retracting bucket arm. If bucket stops moving, lift movable arm slowly and continue turning bucket.

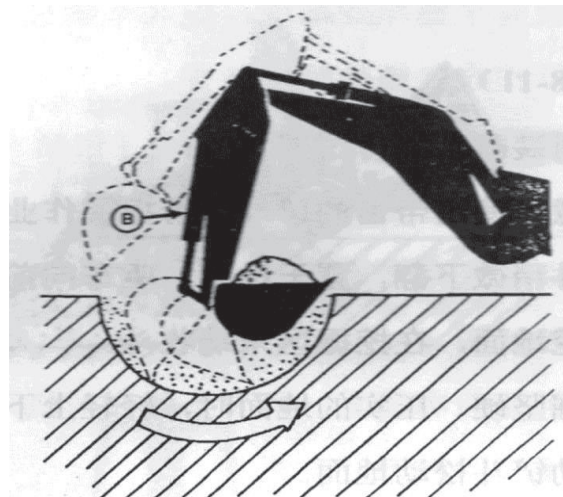

(08-10)

Using marking pole when ditching

Insert the marking poles into ground along ditching direction as visual operation guide. The distance between two marking poles is 9m. The guide marking pole shall be used when machine often deviates from operating direction.

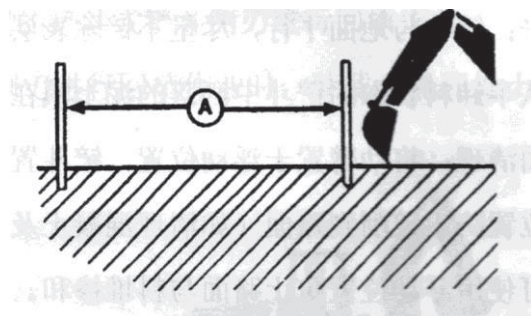

Ditching operations

Digging "V" shaped ditch to prevent from collapsing (Please refer to placing

position of earth deposits).

In case of collapsing and machine can not access to collapsing position to repair in its current position, it is forbidden to back vehicle to collapsing position on excavated ditch. Drive vehicle to collapsing side and repair collapsing place on position of 90°.

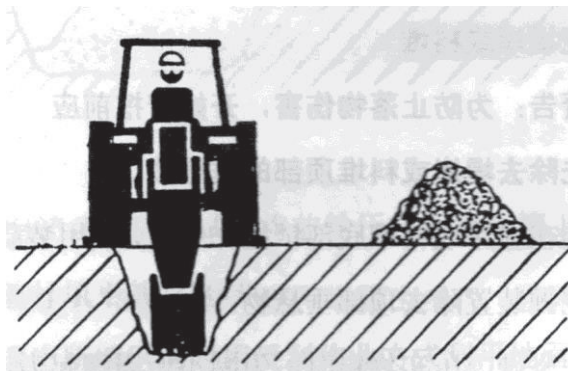

Operation of loading bucket.



Note: Movable arm and bucket can be positioned during running process of vehicle.

1. Lower movable arm onto ground and set it on digging position.
2. Shift gear shift control rod to proper gear to dig, gear I is selected generally.
3. Drive vehicle forward and shovel materials.
4. Lift movable arm and retract bucket to load materials into bucket.



(08-11)

Dig with loading bucket



Note: Use bucket with teeth to dig, turn over bucket downwards slightly and set it on ground. Drive vehicle forwards to dig and shovel ground and retract bucket at the end of digging area.

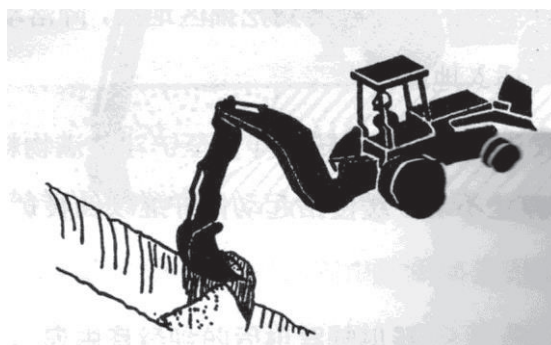

When digging hard and compressed ground, tremble bucket to loosen ground.

Leveling and cleaning road surface

Leveling: Bucket is parallel with ground, not to shovel surface soil possibly. Fill earth splashed and dropped from bucket under semi-unloading state into pothole.

Cleaning road surface: Set movable arm on floating position and bucket on digging position to avoid milling road surface (Such as remove concrete and snow cover). The floating position can be used to prevent road surface from admixing with material pile.

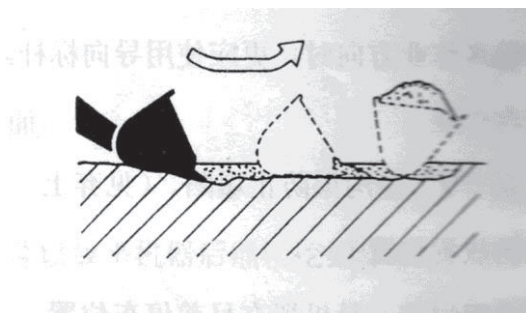

(08-12)

Digging earth bank or windrow



Warning: In order to prevent hanging or suspending substance be removed firstly before shoveling.



Loading bucket or digging device can be used to remove hanging or suspending substances on top before starting shoveling and digging operations for earth bank or windrow.

When shoveling and digging hard, compressed materials, shovel and dig downwards from the top of earth bank or windrow so as to reduce breakout force required.

Under normal conditions, shall shovel and dig upwards from the bottom of earth bank or windrow. The digging face shall keep equal and flat to avoid protruding or hanging and suspending sections. When shoveling and digging earth bank or windrow, the machine and working face shall form angle of 90°.

1. Lower bucket onto ground and set it on shoveling and digging position.
2. Set speed change control rod on gear I position.
3. Drive vehicle forwards to make bucket cut into earth bank or windrow.
4. After bucket is filled with materials, lift and retract it.

Back scraping operations

Run vehicle backwards, use loading bucket to conduct back scraping operations. When conducting back scraping operations, set movable arm on floating position to enable bucket to float up and down with land modification.

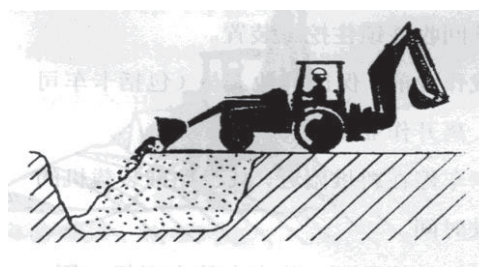

(08-13)

Refilling operations



Warning: In order to avoid accident of turning over, any angle cannot be formed between operating machine and ditch to be refilled. In order to ensure optimum tractive force and stability, straightly drive vehicle to ditch to be refilled.

Important instruction: In order to prevent from damaging machine, forbid using bucket on loading position or side blade of bucket to refill.

When using bucket on loading position or side blade of bucket in final leveling operations, movable arm for loading shall be on floating position.

When refilling in the vicinity of buildings:

Note: When refilling in narrow area, the digging bucket can be used instead of bucket to improve operating flexibility.

When refilling in the vicinity of buildings, push the materials as nearer as possible by the use of bucket, then remove redundant materials by means of back scraping.

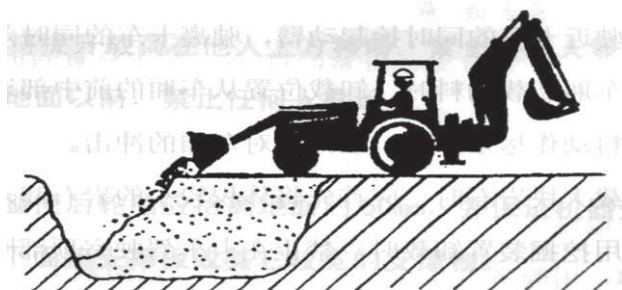

Pit and ditch refilling operations

When some pit and ditch are filled and leveled basically, try to press front wheel onto newly-filled soil while beginning to emptying bucket. In this way, the front wheel will compress newly-filled soil to support vehicle to run forward to fill and level the other arrears.



Note: In order to level ground and refill tyre dint, the ground can scraped to level by means of back scraping when retreating from refilled area.

When large-area refilling:

When levelling ground by large area, scatter a thin layer of materials on entire area whel driving into the area. Run engine at full speed and engage gear I , scatter materials while vehicle is running. At the end of scattering, engage backward gear. Compress newly-refilled materials whiel vehicle is runnung forwards and backwards.

(08-14)

Truck loading

Level the operational field before loading to improve vehicle stability. Retract bucket arm and lock digging device.

Before loading operations, ensure that others personnel (including truck driver) leave the operational field.

Stop truck near to material pile, reduce running time of loaderdigger.

If possible, stop truck on the side of driver to communicate with driver.

If possible, select leeward side to stop truck to avoid dusts entering into eyes or engine air cleaner during unloading process.

Loaderdigger keeps “V” loading path between truck and material pipe.

Lift movable arm while driving near to truck and lower movable arm while driving away from truck to save operating time.

When loading materials into body of vehicle, the unloading position shall from front middle to rear middle of body of vehicle gradually.

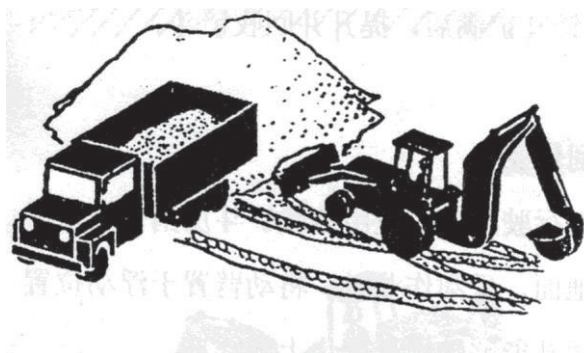

When loading big rock, small-size rock shall be unloaded into body of vehicle firstly to cushion impact of big rock.

When unloading by the use of digging device, forbid turning bucket on top of driver's cab.

(08-15)

Terrace digging



Warning: In order to avoid collapsing of earth bank, forbid cutting into earth back by the use of bucket.



Note: Terrace digging shall begin with leveling ground, level excavating point with digging bucket if necessary.

1. Lean bucket forwards slightly, engage gear I , lower bucket onto ground and drive vehicel forwardd.
2. Pile spoils into long material pile, build into terrace.



Warning: In order to prevent from turning over of vehicle, prevent front tyre from falling on edge of long material pile. During compressing process, forbid paralleling with road edge.

Note: Prevent materials in bucl of vehicle to sinking area of terr



1. Push long material pile to make it form angle of 45~90° with road edge to extend terrace.
2. Only use front wheel to compress spoil pile.
3. Finally level to straighten uphill earth bank to level terrace.

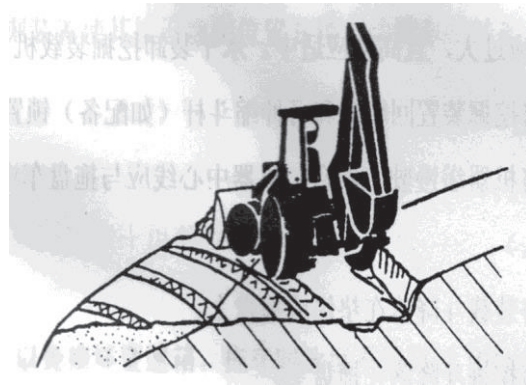
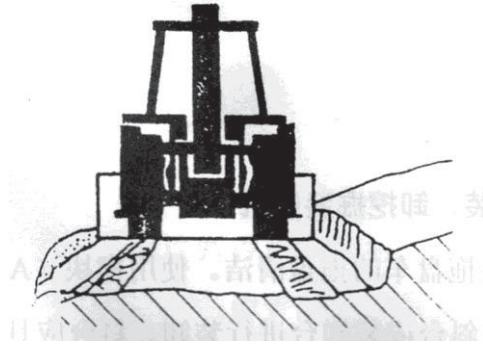

(08-16)

Lifting operations

Warning: It is forbidden to move lifted load suddenly. It is forbidden to lift load to move over the others. It is forbidden for any people to close to lifted load. It is forbidden for any people to close before the lifted load is supported or falls on ground.

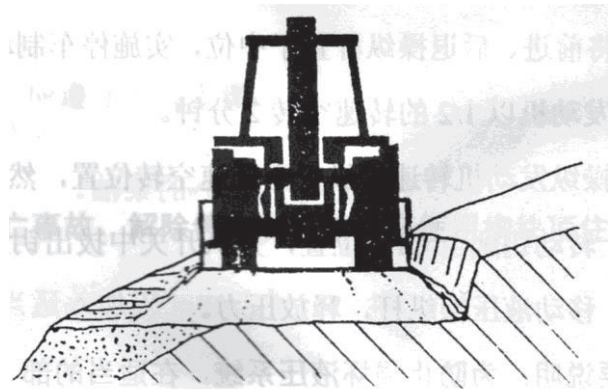

Test the stability of load in accordance with following methods before lifting:

Note: When lifting by the use of digging bucket, lift rear tyre from ground by about 50mm by the use of support leg and ensure machine to be on level position. If ground is too soft, support plate or other wide supporter shall be placed under support leg.



- A. Stop machine near to the load.
- B. Lift the load from ground by about 50mm.
- C. When lifting by the use of digging bucket, always turn load to the same direction.
- D. When keeping the load on the height near to ground, keep the load away

from machine body.

If the stability of machine is affected after lifting load, lower the load to ground and re-lift after adjustment.

Transportation

(09-1)

Loading and unloading loaderdigger with pallet truck

1. Keep pallet of pallet truck clean. Support wheels of pallet truck with wedge block (A).
2. Load and unload with the aid of sloping platform or loading platform. The sloping platform shall have enough strength to support weight of loaderdigger, the angle of sloping platform shall not be too big and its height shall be proper. Load or unload loaderdigger horizontally.
3. Lock turning lock and extensible rod (If equipped) of digging device on locking positions.
4. Drive machine to sloping platform slowly, center line of machine coincides with that of pallet truck. (Please refer to driving instruction in section of driving)

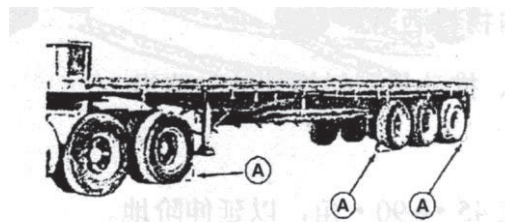

5. Lower loading bucket on wedge block or pallet.
6. Lower digging bucket on pallet.
7. Set forward and backward control rods on middle positions and engage parking brake.
8. Run engine at 1/2 of engine speed and under no load for 2 minutes.
9. Set the operating lever of engine speed on low-speed idle position and then engine stops running.
10. Turn key to OOF position and then pull out key from switch.
11. Move hydraulic operating lever to release pressure.

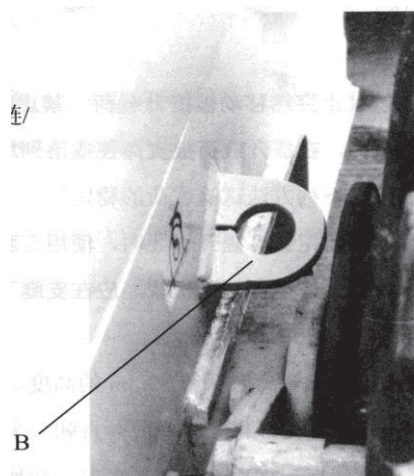

Important instruction: In order to prevent from damaging hydraulic system, fasten trip chain/rope at proper place.

12. Fasten trip chain/rope at place B of vehicle frame, forbid pressing or leaning trip chain/rope against hydraulic pipeline or hose.

13. Fix trip chain/rope for digging bucket on pallet to prevent from occurring movement during transporting process.
14. Block exhaust pipe of engine with rubber belt to prevent the entry of dusts and rain water.

Unload loaderdigger from pallet truck:

1. Stop pallet truck on level ground.
2. Support vehicles of level ground with wedge block
3. Clean pallet of pallet truck and disassemble trip chain/rope, take off rubber belt on exhaust pipe.
4. Unload machine by the use of long sloping platform.
5. Lock brake pedal with locking device for pedal.
6. Set forward and backward control rods on middle positions.
7. Start machine, run engine at low-speed and under no load for several minutes.
8. Lift loading bucket for about 1 foot, lower digging device to make close to ground and lock movable arm and turning frame.
9. Engage gear I for machine and drive down from pallet truck.

(09-2)

Tow truck

Important instruction: Forbid starting engine through tow truck to avoid damaging transmission. The towing speed shall not exceed 10km/h and towing time shall not exceed 1 hour.

Avoid using of tow truck as far as possible, if have to use tow truck, the following steps shall be followed:

1. Stop engine.



Warning: In order to causing personal injury due to unexpected movement of vehicle, the vehicle shall be supported with wedge block before disengaging parking brake.

2. Support wheels of vehicle with wedge block.
3. Set forward and backward control rods on middle positions.



Warning: In order to causing personal injury due to unexpected movement of vehicle, the hand brake must be depressed to disengage parking brake.

4. Depress hand brake to take off wedge block.
5. Draw up parking brake to engage parking brake after towing.

Fuel and lubricating oil

(10-1)

Diesel oil

Consult your local diesel oil supplier about the features of diesel oil supplied.

Recommended diesel oil grade:

In winter, use -10# diesel oil, when air temperature reaches -20°C , select -20# diesel oil. When air temperature is below -30°C , select -35# diesel oil.

In summer, 0# diesel oil can be used.

The used diesel oil shall meet the following features:

Minimum cetane value is 40, it is best to use diesel oil with cetane value of more than 50 (especially when local air temperature is higher than -20°C and altitude is higher than 1500m).

Cloud point shall at least be lower than preset temperature by 50°C .

Sulfur content:

The sulfur content shall not be higher than 0.5% and it is best to be lower than 0.05%.

If the diesel oil with sulfur content of higher than 0.5% is used, the maintenance interval of engine oil and oil filter shall be shortened by half.

It is forbidden to use diesel oil with sulfur content of higher than 1.0%.

Lubricating property

If the lubricating property of fuel is too low or unknown, high-quality diesel oil conditioning agent of proper concentration shall be added.

The biological activity diesel oil having above features substitute petroleum base diesel oil.



Warning: Special attention shall be paid to the disposal of fuel. It is forbidden to add fuel when engine is in operation. No smoking when filling fuel or repairing fuel system.

(10-2)

Diesel oil storage

Proper storage of diesel oil is very important. Clean oil storing and transporting tanks shall be used firstly. Drain water and foreign matters on bottom of tank quantitatively. Fuel shall be stored on convenient position far from buildings.



Important instruction: Prohibit storing fuel in galvanized container. Diesel oil stored in galvanized container can react with zinc to form spilliness. If diesel oil contains water, zinc gel can also be formed. These spilliness and gel will block oil filter quickly, damage oil nozzle and injection pump.

Prohibit using container plated with brass to store diesel oil. Brass is a yellowish alloy of copper and zinc.

Store diesel oil in plastic, aluminium and steel container coated with special coating.

Avoid storing diesel oil for long time. If diesel oil has been stored for more than one month before using, there is slow overturning in oil storing tank or oil filling tank, proper conditioning agent shall be added into diesel oil to stabilize diesel oil performance and prevent water from condensing. The fuel conditioning agent can reduce fuel gel in winter.

(10-3)

Specifications of fuel tank

Capacity.....106L

(10-4)

Diesel engine oil

Determine viscosity grade of used engine oil according to conditions of air temperatures between two oil changes.

The diesel engine oil with multi viscosity grades is recommended use.

If the diesel oil with sulfur content of higher than 0.5% is used, the maintenance interval of engine oil and oil filter shall be shortened by half.

(10-5)

Transmission and axle oil

Determine viscosity grade of used oil according to conditions of air temperatures between two oil changes.

Recommend use YB-N46 (30#) antiwearing hydraulic oil for transmission, because this oil can reduce brake noise and avoid wearing of machine effectively.

Recommend use 20# gear oil for axle.

(10-6)

Hydraulic oil

Determine viscosity grade of used oil according to conditions of air temperatures between two oil changes.

Recommend use YB-N46 (30#) antiwearing hydraulic oil, because this oil can reduce brake noise and avoid wearing of machine effectively.

(10-7)

Lubricating grease

According to specific air temperature conditions, select proper lubricating grease.

Recommend use 2# calcium base grease.

Grease used to wearable strips of side-moving frame and support leg.

Multifunctional lubricating grease (2# calcium base grease) with extreme pressure performance and contains 3~5% supramoly.

(10-8)

Synthetic grease can be used

The other lubricating grease which is not mentioned in this manual may be used to machine working under certain geographical environment.

The synthetic grease which meets the requirement of performance specified in this manual can also be used.

Storage of lubricating grease

The use of clean lubricating grease can ensure machine to work effectively.

Clean containers shall be used to store lubricating grease.

Lubricating grease shall be stored in dry places and free from dusts.

All surfaces of containers shall be clearly marked with names of materials stored.

Waste and oil containers and residual grease shall be disposed of properly.

(10-9)

Mixing use of lubricating greases

Generally, the lubricating grease of different brands cannot be mixed to use. Under general cases, manufacturer mix certain additive into lubricating oil to reach and meet certain feature and performance requirement respectively.

The mixing use of lubricant of different brands can affect performance of this additive and reduce the performance of lubricating oil.

(11-1)

Scheduled maintenance

Hanging “No operating” caution plate



Warning: In order to prevent accidental movement of machine from causing injury and fatal accident, “No operating” caution plate shall be hung in front of control rod when conducting maintenance to prevent other people from misoperating.

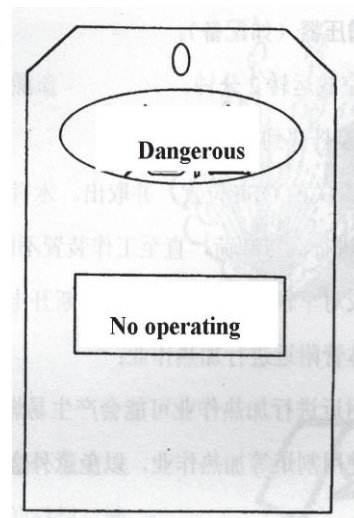

Scheduled maintenance of machine

Regular lubrication, maintenance, inspection and adjustment shall be carried out for machine in accordance with time interval specified in scheduled maintenance table.

When conducting specified maintenance items, the related maintenance items shall be completed at the same time. For example: When conducting maintenance item of after operating for each 500h, the maintenance items specified in maintenances after operating for each 250h, 100h and 10h or daily maintenance.

The maintenance interval specified in the table and this manual is only

applicable to normal operating conditions, in case that the operating conditions are quite execrable, the maintenance period shall be shortened properly.

(11-2)

Avoid earth accumulation

In order to smooth the way for machine maintenance, keep machine clean. The following parts shall be cleaned as required (especially when earth begins to accumulate):

- Support leg hose passing through vehicle frame
- Between rear tyre and antisplash gasket
- Digging cylinder
- Turning point and hose of digging device
- Loading cylinder and articulating point
- Rear axle pin shaft

Use suitable fuel and lubricating oil.



Important instruction: In order to prevent machine from damaging, suitable fuel and lubricating oil shall be used when maintaining.

(11-3)

Preparation before maintenance

Stop and place machine in accordance with the following requirement before leaving from driver's seat and conducting maintenance to machine:



Important instruction: Improper disposal of waste materials will affect environment and ecological equilibrium. The articles containing potential harm used in this machine include: engine oil, fuel, cooling liquid, brake fluid, filter and battery.

It is strictly forbidden to throw water materials on ground, into discharge ditch or any water sources.

1. Stop machine on level road surface.
2. Lower loading device on ground and lock digging device on transporting position.
3. Set gear shift control rod and steering rod on middle positions.



Warning: In order to prevent expected movement of machine from causing personal injury, engage parking brake after setting the steering rod on middle position. Run for 2 minutes under no load.

4. Set rotating speed control rod on low-speed idle position, turn key switch to OFF position and take off key.
5. Move hydraulic control lever to release pressure.

(11-4)

Lock for repairs and maintenance of loading movable arm

The movable arm can be locked on lifting position with locking lever for movable arm if it is necessary to lift loading movable arm when repairing or maintaining.

1. Empty loading bucket and set it on unloading position.
2. Lift movable arm till locking lever can fit over cylinder piston rod.
3. Stop engine and fit locking lever over cylinder piston rod.
4. Lower movable arm till locking lever to be limited.

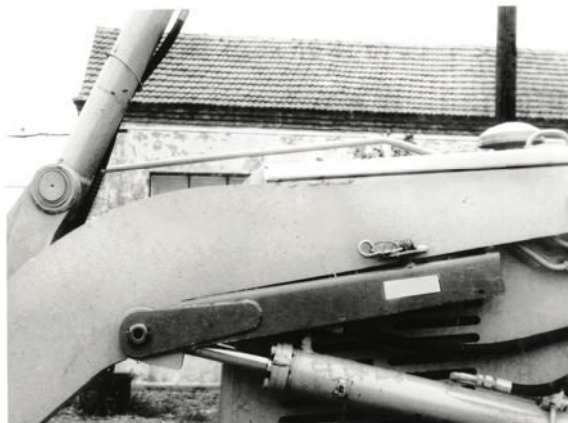

5. Assemble the pin shaft and split pin.

Movable arm returns to storing position:

1. Start engine and lift movable arm slowly.
2. Eliminate pressure of locking lever.
3. Disassemble the pin shaft and split pin.
4. Disassemble locking lever.
5. Fix locking lever on storing position through the pin shaft and split pin.

(11-5)

Switch for access door

Turn knob of switch of access door.

(11-6)

Maintenance and repair records keeping system

The record list to be introduced in following chapters summarily records contents of scheduled maintenance, names of required parts and oil as well as maintenance period.

The purpose of using maintenance and repair record list:

1. Remind driver of conducting scheduled maintenance and reduce machine down time.
2. Smooth the way for calculating machine depreciation and making engineering assessment.
3. Convenient to calculate reduced value.

Maintenance items and record time shall be verified item by item when carrying out machine maintenance.

(11-7)

Oil sampling

The oil sampling is to verify the availability of machine, meanwhile reduce maintenance and repair costs by eliminating hidden dangers and troubles.

Periodic sampling of oil and cooling liquid of different system is generally done before changing oil or replacing filters.

(11-8)

Repair and maintenance records keeping system

Maintenance interval during running in period of new vehicle.

Conduct maintenance according to specified maintenance interval during running in period of new vehicle.

For operation of new vehicle for first 10h, please refer to introduction.

Please refer to regulation in this chapter for maintenance after new vehicle operating for first 100h.

Maintenance interval after running in period of new vehicle.

Conduct maintenance for vehicle according to the following regulations.

When carrying out specified maintenance items, the related maintenance items shall be completed at the same time. For example: When conducting maintenance item of after operating for each 500h, the maintenance items specified in maintenances after operating for each 250h, 100h and 10h or daily maintenance.

Maintenance items when necessary:

Check belt tension	Lubricate side-moving frame
Drain water in fuel tank	Lubricate wearable strips of support leg
Check tyre pressure	Lubricate transmission shaft spline of front driving axle
Check and adjust movable arm lock	Clean driver's cab

Maintenance items after operating for each 10h or daily maintenance items:

Check engine oil level Lubricate articulating points of connecting rod of digging bucket and cylinder piston rod end.

Lubricate articulating places of loading device

Lubricate articulating points of front axle and steering cylinder

Lubricate cross axle head of transmission shaft

Lubricate articulating places of digging device

Lubricate support leg and articulating places



Weekly maintenance

Check cooling liquid level

(11-9)

Required parts

In order to ensure performance and working efficiency of machine, original spare parts produced by Weimeng Company can only be used.

Engine oil filter	Front axle
Fuel filter	Rear axle
Hydraulic oil tank breather filter	Matching tools
Hydraulic oil filter	Air cleaner
Transmission	Tools

(11-10)

Repair and maintenance record keeping system

Model: Site Wizard User:

Vehicle number: Delivery date

Carry out maintenance in accordance with drain oil and oil changing interval, etc specified in maintenance after operating for each 250h, 500h and 1000h.

Maintenance after operating for each 250 hours:

- ⊙ Check axle housing for oil level ⊙ Check transmission for oil level
- ⊙ Check battery electrolyte level and electrode
- ⊙ Change engine oil and replace filter
- ⊙ Check hydraulic oil tank for oil level

Notes:

Date:

Maintained by:

Maintenance after operating for each 500 hours:

- ⊙ Check air inlet hose
- ⊙ Replace oil filter of hydraulic system ⊙ Replace fuel filter
- ⊙ Check movable arm- bucket arm for bolt torques
- ⊙ Check cooling liquid, add conditioning agent if necessary

Notes:

Date:

Maintained by:

Maintenance after operating for each 1000 hours:

- ⊙ Change oil of axle housing
- ⊙ Check hydraulic oil tank for oil level

- ⊙ Check and adjust connecting rod for engine speed control
- ⊙ Clean vent pipe of engine crankcase
- ⊙ Replace air cleaner element

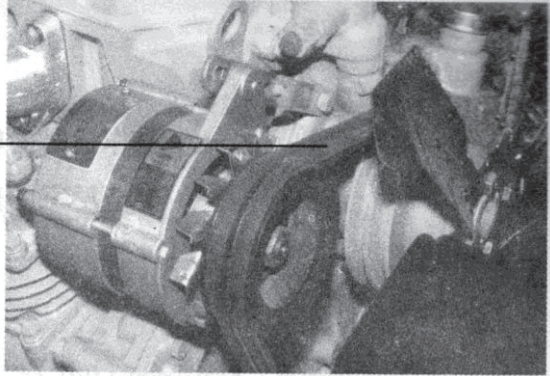
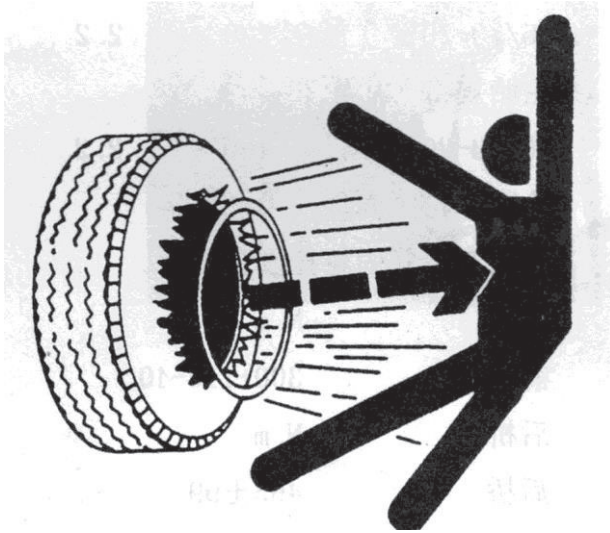
<p>⊙ Change axle wheel-side oil</p> <p>Notes: Date: Maintained by:</p> <p>Maintenance after operating for each 2000 hours:</p> <ul style="list-style-type: none"> ⊙ Adjust valve clearance of engine <p>Notes: Date: Maintained by:</p> <p>Maintenance when necessary (12-1)</p> <p>Belt inspection Check belt for worn and damaged conditions.</p> <p>Drain water and foreign matters in diesel oil tank:</p>	 
---	--

1. Screw down screw plug on bottom surface of oil tank to flow diesel oil for several seconds to drain off water and foreign matters.
2. Tighten screw plug.

(12-2)

Check tyre pressure



Warning: Blowout of tyre and rim may cause serious injury and fatal accident.

Mounting of tyres require proper work clothes and sufficient experiences, which shall be done by authorized agents or maintenance and repair men generally.

Keep proper tyre pressure, the charging pressure of tyre shall not exceed authorized pressure. It is forbidden to cut or weld charged tyre or rim assembly, rim or rim parts, **this is because heat generated by welding operations can increase tyre pressure and cause explosion accident.**

When charging for tyres, clamping device and extension hose shall be used to

avoid making operating personnel stand on front side or upside of tyres, they shall stand on one side of charging tyres. The guard grating netting shall be used if condition permits.

Check tyres and wheels daily. Normal operation cannot be conducted if charging pressure of tyre is low, scuffing and bubble occur to tyres or rim is damaged or rim bolts and nuts are lost.

Use precise instrument with scale grade of 6.9kPa to check tyre pressure.

If tyre contains liquid ballast, air-liquid instrument shall be used to measure tyre pressure, the valve rod shall be located on bottom of tyre when measuring.

When charging for tyres, semi- air charging system lock is clipped on valve rod, operating personnel shall stand one face side or rear side of tyre (For specified value of tyre charging pressure, please refer to this chapter).

(12-3)

Tire charging pressure

Note: The tyre pressure when transporting is different from that when operating. The tyre pressure can be adjusted in accordance with recommendations of manufacturer to meet operating conditions.

Tyre pressure:

Specification of tyre (Front wheel)	kPa	(bar)
16/70-20	220	2.2
Specification of tyre (Rear wheel)	kPa	(bar)
16/70-20	180	2.2

Check wheel fasteners:

Tighten vehicle wheel fastening bolts and fasteners.

Front axle:	N·m
Front axle:	300+110-40
Rear axle:	N·m
Rear axle:	495±99

(12-4)

Locking lever for maintenance and repairs of movable arm for loading

When carrying out maintenance and repairs, the movable arm can be locked on lifting position with locking lever of movable when it is necessary to lift movable arm for loading.

1. Empty loading bucket and set it on loading position.
2. Lift movable arm till locking lever can fit over cylinder piston rod.
3. Stop engine and fit locking lever over cylinder piston rod.
4. Lower movable arm till locking lever is limited.

Movable arm returns to storing position:

1. Start engine and lift movable arm slowly and eliminate pressure of

locking lever.	
2. Disassemble pin shaft	

and split pins.

3. Disassemble locking lever.
4. Fix the locking lever of movable arm on storing position by the use of pin shaft and split pins.



(12-5)

Check and clean hydraulic oil tank and oil strainer

Take off oil tank cover (A), check oil strainer, clean thorough if necessary.

(12-6)

Lubrication of transmission of driving axle

Press lubricating grease into lubricating nipple till lubricating grease spill from joint. (Please refer to instruction to the section of fuel and lubricating oil for models of recommended lubricating grease).

Scheduled maintenance-Maintenance after operating for each 10h and daily maintenance.

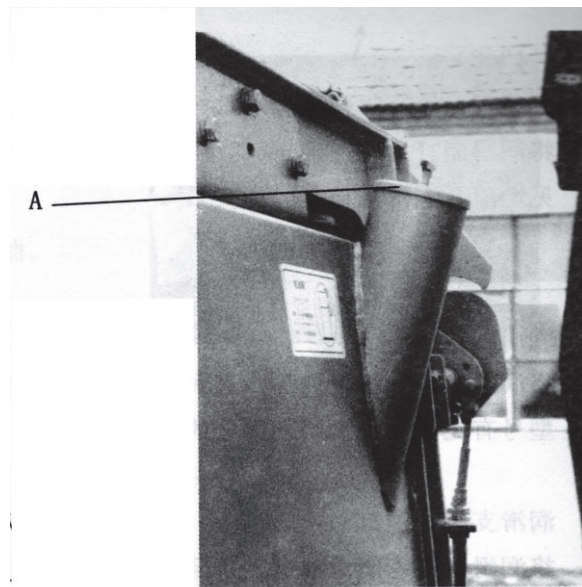

(13-1)

Check engine oil level



Important instruction: In order to prevent machine from damaging, forbid running engine when oil level is lower than display position of oil scale.

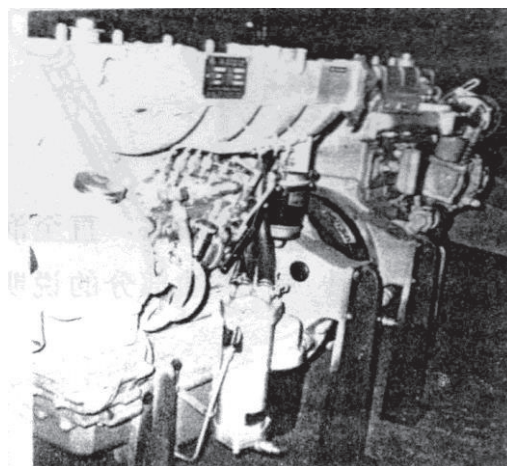

Before putting machine into operation, the reading of oil level obtained by

measuring under cold state of machine is most accurate.

1. Stop vehicle on level road surface.
2. Take off oil scale to check oil level.

Before starting engine: if oil level is above display position of oil scale, which indicates engine oil tank is full of engine oil. When oil level higher than above of lowest display position of oil scale, engine can run normally.

After stopping engine, 10 minutes shall be firstly remained for returning oil into oil sump, then check oil level. Under normal conditions, oil level shall be above lowest display position after engine stopping running for 10 minutes.

3. Take off oil filler cover (A) to fill oil if necessary.

(Please refer to instructions to section of fuel and lubricating oil).

(13-2)

Lubrication of articulated pin shaft of loading section

Press lubricating grease into lubricating nipple till lubricating grease spill from joint. (Please refer to instruction to the section of fuel and lubricating oil for models of recommended lubricating grease).

(13-3)

Lubricate front axle

Press lubricating grease into lubricating nipple till lubricating grease spill from joint. (Please refer to instruction to the section of fuel and lubricating oil for models of recommended lubricating grease).

Lubricate support leg and oil cylinder

Press lubricating grease into lubricating nipple till lubricating grease spill from joint. (Please refer to instruction to the section of fuel and lubricating oil for models of recommended lubricating grease).

(13-4)

Lubrication of digging device

Press lubricating grease into lubricating nipple till lubricating grease spill from joint. (Please refer to instruction to the section of fuel and lubricating oil for models of recommended lubricating grease).

(13-5)

Lubricate rear axle

Press lubricating grease into lubricating nipple till lubricating grease spill from joint. (Please refer to instruction to the section of fuel and lubricating oil for models of recommended lubricating grease).

(14-1)

Weekly maintenance

Lubricate universal joint of transmission of driving axle.

Press lubricating grease into lubricating nipple till lubricating grease spill from joint. (Please refer to instruction to the section of fuel and lubricating oil for models of recommended lubricating grease).

Maintenance after operating for each 250h

(15-1)

Check oil level of driving axle

1. Take off screw plug (A) to check oil level. Oil shall be filled to bottom of screw plug.

Note: Gear oil has been filled before leaving factory. If oil level is too low, 20# and 30# gear oil can be filled to proper oil level.

2. Fill oil through screw plug hole if necessary.

(Please refer to instruction to the section of fuel and lubricating oil for models of recommended lubricating grease).

3. Assemble screw plug.

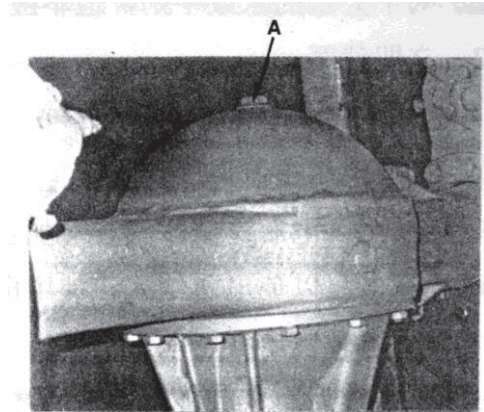

(15-2)

Checking batter for liquid level and pole plate



Warning: Battery gas can cause explosion accident; therefore, keep battery away from fire sources and spark. The battery liquid level can be checked with the aid of flashlight.

Sulfuric acid contained in battery can result in serious burn, pay attention to avoid touching skin, eyes or clothes.

In order to avoid harming of battery liquid to human bodies:

1. Fill battery liquid in place with good ventilating condition.
2. Wear protective goggles or rubber gloves
3. Avoid inhaling harmful gas when filling battery liquid.
4. Avoid dropping and scattering battery liquid.

If battery liquid sprays on body:

1. Rinse skin with fresh water.
2. Neutralize acid with saleratus or calcium oxide.

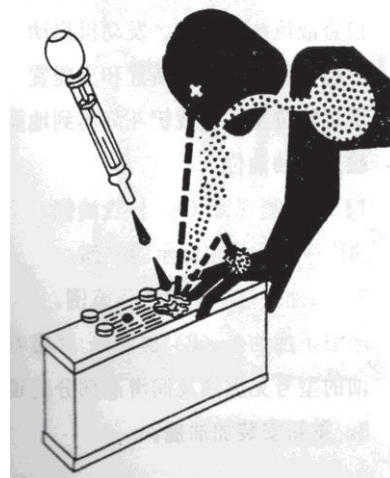

3. Rinse eyes with fresh water for 15~30 minutes and take medical treatment immediately.

If drink sulfuric acid by mistake:

1. Prohibit adopting methods that can induce vomiting.
2. Drink a great amount of water or milk, while cannot exceed 1.9L.
3. Take medical treatment immediately.

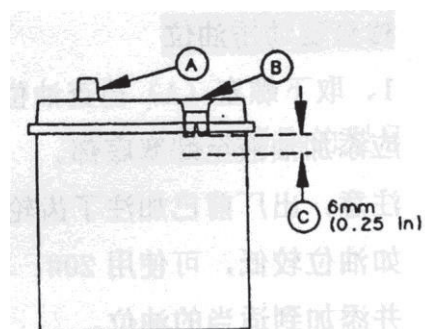

1. Dismount battery box cover.

Important instruction: The batter shall be charged when it has been filled with water under icing temperature to avoid icing of battery. Charge with battery charger or by running engine.

2. Fill proper amount of distilled water into each battery cells, overfilling is forbidden.

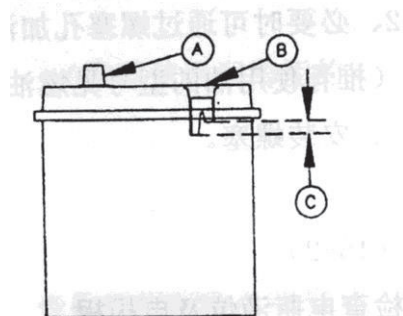

Warning: The earth wire (negative pole) shall be connected later when connecting wires and the earth wire shall be disconnected when disconnecting wires.

3. Earth wire (negative pole) shall be connected later when connecting wires and the earth wire shall be disconnected when disconnecting wires.
4. Brush pole plate (A) and wire clip with hard brush.
5. Apply lubricant to around areas of pole plate of battery.
6. Assemble and tighten wire clip, the positive pole shall be connected firstly.

(15-3)

Checking hydraulic oil tank for oil level

Note: Stop vehicle on level road surface, check hydraulic oil tank for oil level. Check oil level before starting engine, set digging device and support leg on transporting positions, lower loading bucket on ground.

Check cold oil level.

1. Check oil level through side-view window (A). oil level shall be at the middle of oil level mark.

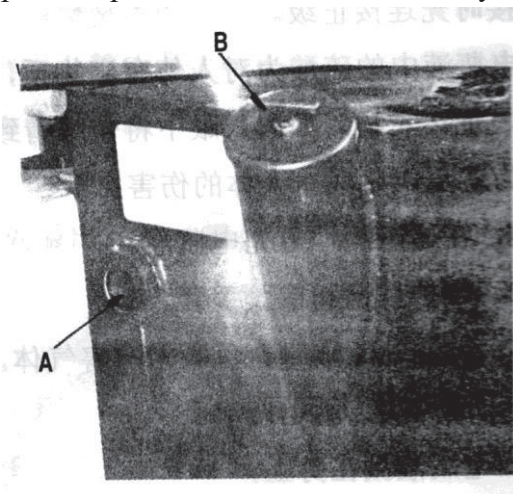

2. When oil level is lower than normal working range, oil filler cover (B) shall be taken off to add oil. (Please refer to instruction to the section of fuel and lubricating oil for models of recommended lubricating grease)
3. Reassemble oil filler cover.

(15-4)

Checking transmission for oil level

1. Stop machine on level ground.



Warning: In order to causing personal injury due to unexpected movement of vehicle, the steering rod shall be set on middle position and parking brake shall be engaged after stopping the vehicle.

2. Engage parking brake.
3. Set steering rod on middle position.
4. Start engine and run it for 3 minutes at idle speed.

Preheat transmission oil.

5. Engine runs counterclockwise when it is running at idle speed.

Note: Normal hot oil level may be higher than indicating screw.

6. Checking transmission for oil level, if oil level is not on normal position, fill oil. (Please refer to instructions to section of fuel and lubricating oil)
7. Mount oil level indicating bolt, turn clockwise and tighten.

(15-5)

Changing engine oil and oil filter



Important instruction: If the diesel oil with sulfur content of higher than 0.5% is used, the maintenance interval of engine oil and oil filter shall be shortened by half. Engine oil shall be changed even running time of not exceed 250h before season changing.

1. Run engine to preheat engine oil. Stop machine on level road surface and engage parking brake, stopping engine.
2. Screw off screw plug to drain oil. Dispose of water oil properly.

Specification of engine oil

Capacity.....8.5L

3. Turn oil filter with proper spanner counterclockwise and take off it from its seat.

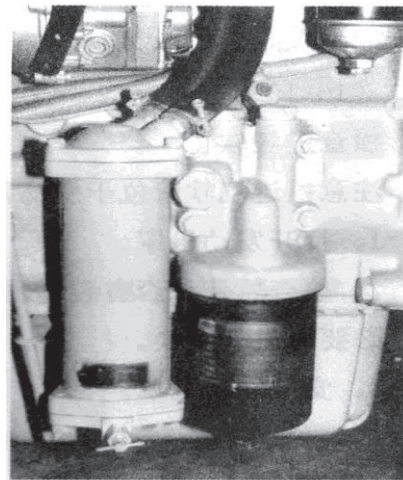

4. Coat a thin layer of oil on new filter seals, assemble oil filter and turn it clockwise till seal gasket contact with mounting surface and then tighten oil filter with spanner.

Important instruction: Try to start engine for 10 seconds with starting it actually after replace oil filter and starting engine to charge oil for oil filter.

5. Start engine and run it at idle speed.
6. Engine misses, check drain plug and oil filter for blockage, tighten oil filter if necessary. (Please refer to instructions to oil level inspection in the section of maintenance after operating for each 10h or daily maintenance).

(15-6)

Checking wheel-side housing for oil level

1. Turn wheel-side housing till wheel-side drain plug (A) becomes level.

Note: Wheel side has been filled with 20# or 30# gear oil before leaving factory. If oil level is too low, oil can be filled to specified oil level.

2. Take off screw plug and check to see whether oil level reaches specified level.

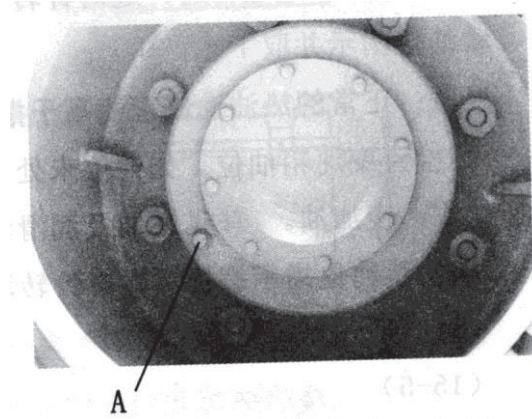

3. Fill oil to screw plug hole if necessary. (Please refer to instructions to section of fuel and lubricating oil for model of recommended oil)
4. Assemble screw plug.
5. Repeat above step and check wheel side oil level on other side.

Maintenance after operation of each 500h

(16-1)

Checking air inlet hose

Note: Air inlet hose is located on back side of air cleaner housing.

1. Open engine cover.
2. Check hose for crack and replace if necessary.
3. Assemble engine cover.

(16-2)

Replacing oil filter of hydraulic system

1. Turn hexagon bolt above upper cover counterclockwise and take off oil

filter and filter element

2. Place new filter element into housing and coat a thin layer of oil on seal ring of newly-mounted oil filter and assemble the seal ring till touch with mounting surface and tighten then.
3. Check hydraulic oil level.
4. Start engine and run it for 2 minutes to charge oil for filter element and exhaust air from charging oil pipe.
5. Engine misses, check hydraulic oil level. (Please refer to instructions to inspection of hydraulic oil level in maintenance for operation of each 250h).
6. Check around area of oil filter for oil leakage. Tighten oil filter to prevent from oil leaking.

(16-3)

Checking movable arm-Tightening condition of bucket arm pin

Checking movable arm- Check whether tightening condition of bucket arm pin is proper. Tightening torque of bolt:

Movable arm –Tightening torque of bucket arm pin bolts

Tightening torque.....6200N·m

(16-4)

Checking conditioning agent of cooling liquid



Warning: High-temperature liquid spouted from high-pressure cooling system may cause serious scald.

Water filler cap can be taken off manually when engine is under cold state or cooled enough to touch by hands. Loosen water filler cap slowly and slightly and open water tank cover after releasing pressure completely.



Note: Check cooling liquid after operation of each 500h or 6 months or when changing 1/3 or above 1/3 of cooling liquid, add conditioning agent if necessary.

Maintenance after operation of each 1000h

(17-1)



Note: Waste oil shall be disposed of properly.

The front driving axle has been filled 20# or 30# gear oil before leaving factory. If oil level is too low, fill oil to proper oil level.

1. Take off screw plug to drain oil. Waste oil shall be disposed of properly.

specified value of oil capacity of front axle housing

Capacity.....6.5L

2. Turn over axle housing and fill oil to position of screw plug.
(Please refer to instructions to fuel and lubricating oil for model of recommended oil).
3. Assemble screw plug.

(17-2)

Checking engine speed

1. Preheat engine to normal operating temperature.
2. Measure engine speed with tachometer.

Idle speed.....850rpm

Quick-speed idling speed.....2375±25rpm

(17-3)

Checking and adjusting connecting rod of engine speed control

1. Move engine speed control rod onto most front position.
2. Measure whether compensation dosage of injection pump control rod meet specified value:

Compensation dosage when engine speed control rod is on most front position

Distance.....3~6mm

3. Adjust shifting yoke on engine speed control rod to reach proper compensation dosage.
4. Move engine speed control rod onto most rear position. Measure whether compensation dosage meet specified value:

Distance.....1.5mm

5. Recheck the compensation dosage when engine is idle running at high-speed.
6. Open oil tank cover and adjust foot control pedal.
7. Remove pin shaft C and relieve pulling yoke A and adjust length of screw to enable foot control pedal stop floor when engine speed control rod is located at most front position.

(17-4)

Changing oil for transmission



Note: Waste oil shall be disposed of properly.

1. Take off drain plug (A) from bottom of transmission and drain oil into proper container.
2. Turn oil level observation screw plug counterclockwise and take it off.

3. Assemble drain plug and take off oil filler plug from upper end cover of transmission, fill oil in transmission through oil filler. (Please refer to instructions to fuel and lubricating oil for model of recommended oil).
4. When filling oil to position of oil level observation plug, turn oil level observation plug clockwise and tighten.

(17-5)

Changing hydraulic oil

1. Stop vehicle on level road surface.
2. Set digging device and support leg on transporting positions, lower loading on ground. Stop engine.
3. Take off oil filler cap of oil tank.

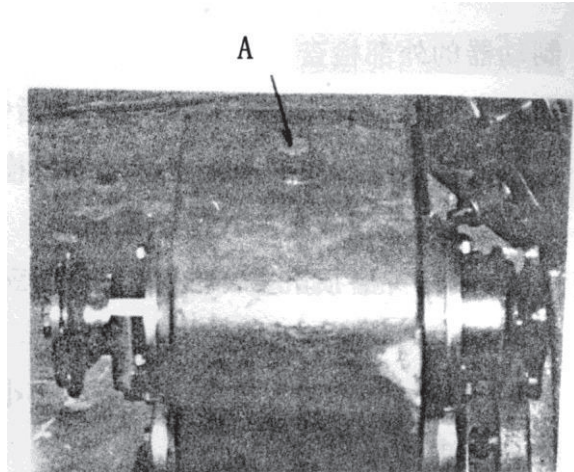

4. Screw off drain plug to drain oil. Retain enough time to drain oil. Dispose of waste oil properly.

Hydraulic oil tank

Capacity.....37L

5. Replace hydraulic oil filter (Please refer to maintenance for operation of each 500h).
6. Close drain plug.
7. Fill oil for hydraulic oil tank. (Please refer to instructions to chapter of fuel and lubricating oil).
8. Check oil level.

(17-6)

Changing oil for wheel-side housing

1. Turn vehicle wheel till drain plug (A) reaches minimum point, take off screw plug and drain oil. Dispose of waste oil properly.

Oil of driving axle housing

Capacity.....1L

2. Assemble screw plug.
3. Turn vehicle wheel, the screw plug (A) shall be located at maximum position.

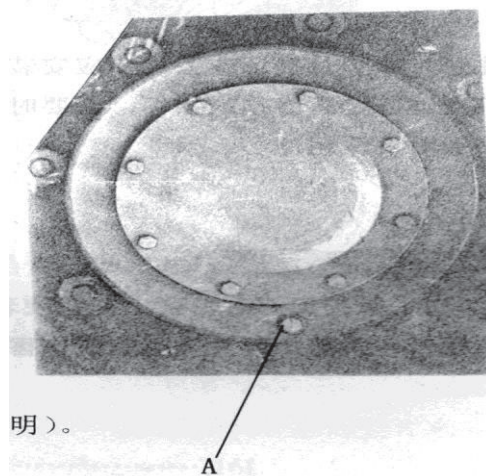

4. Fill oil to make oil level reach bottom of filler plug (A) hole. (Please

refer to instructions to fuel and lubricating oil for models of recommended oil).

Maintenance after operation of each 2000h

(18-1)

Adjusting valve clearance of engine (For details please refer to Operation Manual for Engine.)

Maintenance and service

(19-1)

External inspection of brake

The first inspection shall be carried out after operation of 5000h; hereafter, check once after operation of each 1000h.

Check more frequently if brake is operated for excessive times.

1. Check worn conditions of brake disk through external inspection.
2. If brake disk is worn seriously, take it off to replace.

(19-2)

Checking air cleaner element



Important instruction: In one of the following cases, replace coarse filter element:

1. Filter element is damaged.
2. When filter element cannot be cleaned clean.
Fine filter element cannot be cleaned.

In one of the following cases, mount new filter element:

1. If coarse filter element is damaged or need to be replacd.
2. Observe that filter element becoming dirty.

Note: New filter element shall be mounted if spacer is damaged or missing. Check whether filter element has been damaged or worn, replace if necessary. Clean coarse filter element if necessary.

(19-3)

Removing dusts on filter element

1. Beat filter element with palm. It is forbidden beat filter element on hard surface.

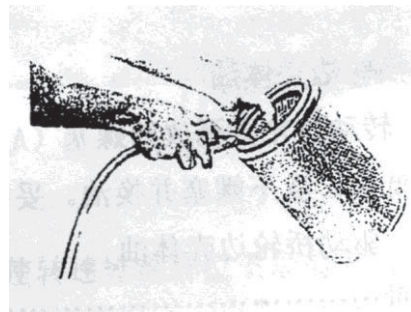
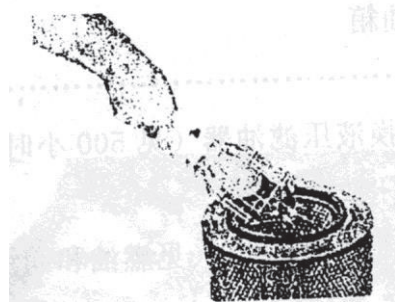



Warning: In order to prevent debris splash from causing injury, pressure of compressed air shall be less than 690kpa when blowing wash filter element with compressed air. During the blowing wash process, it is forbidden for other people to enter into work area, working personnel shall wear protective clothing and safety goggles.

2. If fails to remove dusts by means of beating with palm, the compressed air with pressure of less than 690kpa shall be used to blow wash.
3. Blow wash filter element from inside to outside and from up to down. Be careful not to damage filter element.

(19-4)

Service and maintenance of cooling system

Liquid spouted from high-pressure cooling system may cause serious scald. Stop engine. The water filler can be taken off when water tank is cooled enough that can touch by hands. Firstly loosen water filler cap slowly and slightly, open water tank cover after releasing pressure completely. Cooling water shall be changed for cooling system after operation of each 5 years or 5000h.



Checking radiator

Check radiator for dirt, damage, crack and its joints for loosening and damage. Clean radiator fins. Tighten pipe clips if necessary.

(19-5)

Cooling system

Capacity.....16L

1. Release pressure and take off water tank cover.



Note: Water drain valve of water tank is mounted on bottom of machine

2. One hose is connected to water drain valve of water tank.
3. Turn water drain valve counterclockwise and open this valve.
4. Open water drain valve and drain cooling water in engine body.

(19-6)

Cooling liquid of diesel engine

Filling cooling liquid in cooling system of engine can prevent from corroding and prevent cylinder sleeve from rusting and prevent from icing as well.

It is best to use the following engine cooling liquids:

The glycerol base engine cooling liquid with concentration of 50 after mixing with water can prevent from icing. If it is necessary to operate under very low temperature, consult agent to take antifreezing measures.

Quality of water is very important to performance of cooling system. The distilled water, deionized water can be mixed with glycerol base engine cooling liquid to use.



Important instruction: It is forbidden to use sealing additive for cooling system or antifreezing agent containing sealing additive.

Drainage interval of cooling liquid:

Drain cooling agent of engine filled before leaving factory after operation of first 3 years or 3000h of machine and rinse cooling system, hereafter the water drainage interval shall be determined according to the actually used cooling liquid. Rinse cooling system after draining water and add new cooling liquid.

(19-7)



Warning: High-temperature liquid spouted from high-pressure cooling system may cause serious scald.

Stop engine, water filler cap can be taken off manually when engine is under cold state or cooled enough to touch by hands. Loosen water filler cap slowly and slightly and open water tank cover after releasing pressure completely.

Take off water tank coverm cooling liquid level reaches bottom of waer filler hole.

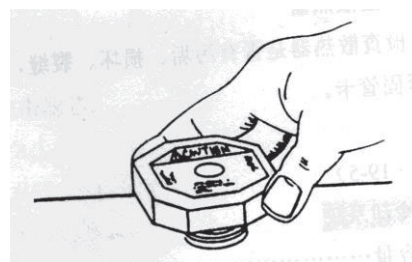

Important instruction: Only permanent low-silicon glycerol antifreezing fluid can be filled into cooling liquid. The other types of antifreezing agents will damage cylinder sealing members.

Freezing temperature: Add permanent low-silicon glycerol antifreezing agent (excluding leak preventive) and clean softening water.

(19-8)

Forbid maintaining oil nozzle



Important instruction: Forbid repairing or disassembling oil nozzle. The following causes can shorten service life of oil nozzle:

1. Overheating

2. Misoperation
3. Poor quality fuel
4. Idling time is too long.

Malfunction of oil nozzle or with oily soil will affect normal running of engine.

Forbid adjusting injection pump.



Important instruction: Prohibit using steam to clean injection pump or splashing cold water on injection pump during running process of engine or before cooling injection pump to avoid jamming oil pump.

Clean dirt and dusts on oil pump regularly.

If adjust injection pump by the means that have not be permitted by manufacturer, the warranty period will be terminated.

(19-9)

Notes for operation of engine and voltage regulator

When connecting battery, the following rules shall be followed:

1. When operating on generator or voltage regulator or working in their around areas, disconnect negative cable of battery.
2. Prohibit polarizing generator or voltage regulator.
3. Ensure the cables on generator have been connected correctly before connecting battery.
4. Prohibit earthing output electrode of generator.
5. When battery is under connecting state or engine is under running state, prohibit disconnecting or connecting any connecting lines on generator or voltage regulator.
6. The correction of electrode shall be noticed when connecting battery or auxiliary battery: Positive pole is connected to positive pole, vice versa.
7. Prohibit disconnecting connections of battery when during charging or running process of engine.
8. Connecting cable of battery shall be disconnected firstly when connecting battery charger.

(19-10)

Careful maintenance of battery



Warning: Battery gas can cause explosion accident; therefore, keep battery away from fire sources and spark. The battery liquid level can be checked with the aid of flashlight.

Prohibit checking charging condition of battery by means of putting metal block on pole plate. Generally, potentiometer or hydrometer is used to measure.

When disassembling battery wire, the minus earth wire clip is generally

removed firstly.

The positive pole shall be connected firstly when connecting.

Sulfuric acid in battery liquid is harmful substance to human bodies, which can burn skin and damage clothes; it can blind people if it is splashed into eyes.

1. In order to avoid harming of battery liquid to human bodies: Fill battery liquid in place with good ventilating condition.
2. Wear protective goggles or rubber gloves
3. Avoid inhaling harmful gas when filling battery liquid.
4. Avoid dropping and scattering battery liquid.

If battery liquid sprays on body:

1. Rinse skin with fresh water.
2. Neutralize acid with saleratus or calcium oxide.
3. Rinse eyes with fresh water for 15~30 minutes and take medical treatment immediately.

If drink sulfuric acid by mistake:

1. Prohibit adopting methods that can induce vomiting.
2. Drink a great mount of water or milk, while cannot exceed 1.9L.
3. Take medical treatment immediately.

In case that electrolyte splash on floor, one of the following solvents can be used to neutralize: Add 0.5kg saleratus into 4L water or add 0.47kg household ammonia into 4L water.



Important instruction: Electrolyte can damage paint or metal surface of machine; therefore take notice not to splash or spill battery liquid on vehicle.

(19-11)

Checking specific gravity of battery fluid



Warning: Battery gas can cause explosion accident; therefore, keep battery away from fire sources and spark. The battery liquid level can be checked with the aid of flashlight.

Prohibit checking charging condition of battery by means of putting metal block on pole plate. Generally, potentiometer or hydrometer is used to measure.

When disassembling battery wire, the minus earth wire clip is generally removed firstly.

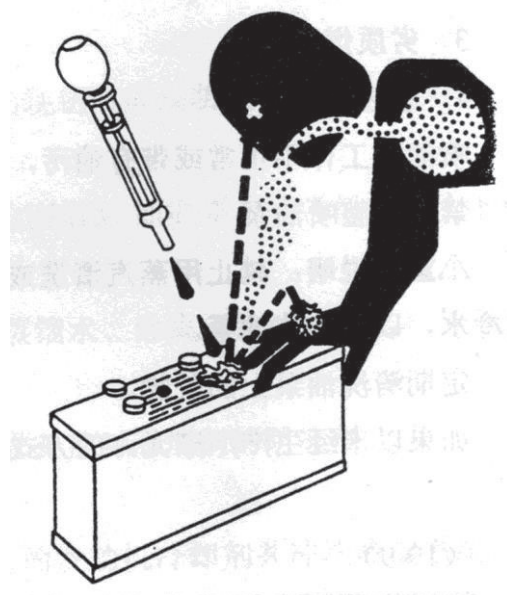

The positive pole shall be connected firstly when connecting.

Check the specific gravity of battery fluid.

After charging, the specific gravity value of battery fluid shall be 1.260, if specific gravity value is less than 1.200, battery need charging.

Note: When operating in cold area, the specific gravity value of battery fluid shall be 1.280.

▲ **Warning:** To avoid personal injury caused by battery explosion, it is forbidden to charge frozen battery. Before charging, battery temperature shall be raised to 16 °C. When charging battery on machine, disconnect earthing clip of battery in case that parts of electrical equipment are damaged.

▲ **Important instruction:** When specific gravity of battery electrolyte is 1.150 or below this value, it is forbidden to use battery charger as auxiliary power supply. When connecting or disconnecting, charger shall be closed first.

Battery charger can act as auxiliary startup power supply.

Battery charging shall be conducted at places with excellent ventilation.

When battery casing gets hot or battery electrolyte begins to volatilize, stop or slow down charging speed of battery. Battery temperature must not exceed 52°C.

(19-12)

Disassemble battery

▲ **Important instruction:** Check if electrical wires are worn or damaged and if joints are loose or eroded.

1. Firstly disconnect negative cable of battery, and then disconnect the positive cable.
2. Dismount bolts or support bracket
3. Lift battery out of battery box.

(19-13)

Change fuse

▲ **Important instruction:** Before installing fuse, make sure of its correct current loading so as not to damage electrical equipment system or cause system overload.

(19-14)

Welding operation on the vehicle

▲ **Important instruction:** Disconnect earthing cable of battery in case peak voltage damages generator or instrument.

Earthing clip of welder shall be connected around welding area in case of discharge inside load supporting part.

(19-15)

Check working cycle time of machine

Manipulate hydraulic control lever until bleed up air in hydraulic system and preheat oil. Check degree of freedom of movement of all control levers and the correctness of directions.

Based on working cycle time specified in the following chart, if actual working cycle time deviates from the specified time too much, check if there is trouble with hydraulic system and eliminate it in time.

Working cycle time.

(19-16)

Installing bucket teeth of digging bucket

1. Add closing ring into round hole of toothholder, install tooth tip, punch in cylindrical pin (the thinner part of cylindrical pin shall be correspondent with closing ring).
2. When digging rock or frozen earth area, special bucket teeth shall be used.
3. If tooth lip is damaged, change for new parts.

(19-17)

Maintenance instruction of metric bolt fixed flange joint

1. Split type flange: Firstly, assemble flange block, but not fasten. Make sure split mouth centered and vertical to interfac. Tighten up manually socket cap screw, fasten flange block in place. It is forbidden to extrude and distort O ring.

Each part shall be positioned correctly and tightened up manually. Firstly, fasten one screw, then the digonal screw, and finally the rest two screws. Tighten up all screws according to tightening torque specified in the following chart.

It is forbidden to use pneumatic wrench. It is forbidden to tighten other screws after fully tightening one screw or excessively fasten screw.

(19-18)

Check hydraulic pipeline and joints

▲ **Warning:** Effluent high-pressure fluid under high pressure will sting skin and cause serious injury. When disconnecting hydraulic or other pipeline, release of pressure shall be conducted firstly. Tighten up all joints before exerting pressure. Paperboard can be used to check leakage to prevent hand or body from being injured by high-pressure fluid.

If stung by high-pressure fluid, go to the doctor immediately, eliminate poisonous liquid as soon as possible to avoid erosion.

Regularly check all oil pipes, hoses and pipe joints for leakage. Make sure pipe clip in the proper position and fastening state. Assure that hose is not distorted or touched by other components. If wear or damage occurs, replace in time.

Pipeline with impression can cause overheated oil temperature. Replace pipeline immediately if impression phenomenon is found.

When fastening pipe joints, two wrenches shall be used to avoid breakage or bending of joints or pipeline.

(19-19)

Maintenance instruction of seal joint of angle part

Straight joint

1. Check if O ring base is clean or damaged.
2. Lubricate O ring with petrolatum. Protect O ring by entangling threaded portion by adhesive tape. Make O ring slide over tape and enter slot. Remove adhesive tape.

Curved joint

1. Locknut and backup washer are installed completely to front end of joint.
2. Screw joint into threaded base until backup washer touches base surface.
3. Turn front end of joint properly anticlockwise (at most for one round) .

Note: Hold front end of joint with one wrench and fasten locknut and washer to the proper torque.

Operational testing

(20-1)

Operational testing procedure

All systems and functions of machine can be checked by the following testing procedure. Quick check of working condition of machine can be realized by all round looking check and executing certain inspection items in driver's cab.

If meeting trouble or problem in operating the machine, the following testing content can help user to determine cause of trouble, find method of adjustment and complete simple repair by user himself so as to shorten downtime.

Testing material after completion of operational testing can help user or the local agent to determine which testing method or repair method can be adopted to restore machine.

Completion of the following testing needs a flat and spacious site, but does not need any tool or facility.

Before testing, visual inspection (oil level, oil fluid condition, outside leakage, loose fastener, link mechanism and circuit, etc) shall be firstly conducted. Most of testing work shall be conducted under working temperature.

(20-2)

Inspection of braking system

Inspection of limiting of brake pedal	Step down brake pedal. See: Whether brake pedal touch limit screw? Note: This can ensure unidirectional braking valve to open.	Yes: Go on next inspection. No: Adjust brake pedal limit. Consult your local agent.
Inspection of connecting rod of braking system	 Step pedal with force of 267N. Observe/Feel: brake pedal shall have no elastic sensation (Caused by air in system).	Yes: Go on next inspection. No: Exhaust gas for braking system; see instructions to exhausting of braking system in chapter maintenance and service. Consult your local agent.

Inspection of parking brake	Stop machine on slope with small slope angle, the front of machine faces to direction of fall. Move steering rod to middle position; disengage parking brake and service brake. Let machine slide by several meters, engage parking brake. Observe: Whether machine stops sliding? Disengage parking brake.	Yes: Go on next inspection. No: Consult your local agent.
-----------------------------	---	--

Inspection of function of parking brake	Start machine, accelerate 1200rpm. Engage parking brake. Move steering rod to forward position. Gear shift rod engages gears from low to high speed gears, running time at each gears is 5s. Move steering rod to middle position. Recover engine throttle to slow-speed idle state and stop engine. See: Whether machine cannot move when engaging any gears. See: Indicator lamp of parking brake shall light.	Yes: If machine can move when engaging any gears, consult your local agent. No: If indicator lamp does not light, consult your local agent. Yes: Go on next inspection.
---	---	---



(20-3)

Inspection of steering system

Inspection of steering system	Lift loading bucket from ground. Lift rear of machine from ground with support legs. Engine speed is about 1000rpm. Turn steering wheel for several times between left and right limits. See: Whether rotation of front frame to two directions is smooth? See: Whether front frame stops rotating when steering wheel stops rotating? Note: Internal leakage or jamming of steering rod will cause that front frame stops steering after steering wheel stops turning.	Yes: Go on next inspection. No: Check hydraulic oil level, consult your local agent.
Inspection of leakage of steering system	Note: Hydraulic oil temperature shall be working temperature. Keep engine under low-speed idle state. Turn steering wheel to right limit. Then continue turning steering wheel with force of 11.3N.m, keep speed of steering wheel unchanged. Turn steering wheel to left limit in the same way, check for leakage. Observe: Whether number of revolutions of steering wheel to right or left is less than or equal to 4~9 turns? Less than or equal 4~7turns is number of revolutions of steering wheel under normal operating conditions.	Yes: Go on next inspection. No: If steering wheel turns for more than 7 turns, determine steering valve or oil cylinder to which leakage occurs. Consult your local agent.
Inspection of steering priority valve	Keep engine under low-speed idle state. Turn steering wheel to left and right limits. Take notice of force required by turning steering wheel, turn steering wheel to limits and apply constant pressure. Observe/feel: When steering wheel stops turning, whether steering cylinder stops steering? Operating force of steering wheel is normal or not? Observe/listen: After steering wheel stopping on limit, reading of rpm on tachometer (if equipped) or engine speed drops?	Yes: Go on next inspection. No: When steering is laboursome or engine speed drops, consult your local agent.

(20-4)

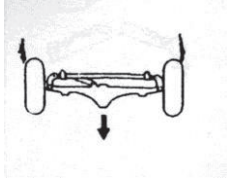
Inspection of transmission system

Inspection of front wheel calibration		Engage high-speed forward gear for machine, run machine on road surface paved loose materials. Observe: Whether tyre mark deviates from center and produce overbending?	Yes: Go on next inspection. No: If tyre mark deviates from center, the wear of tyre will increase. See instructions to checking and adjusting tyre toin.
Inspection of engine and motor	 gear I for transmission. Move steering handle on forward position. Keep engine under quick speed idle running state. Observe: Whether stall occurs to rear wheel? Note: You can know basic functions of engine, transmission and motor through this inspection.	Set loading bucket on ground and support on earth dike or fixing article. Engage	Yes: Go on next inspection. No: if rear wheel stall easily, please refer to “engine underpower” in the engine section of troubleshooting chapter or “Machine underpower or act slowly” in transmission system section. Consult your local agent.
Inspection of running control function, electrical system	Turn key switch to ON position. Observe: Switch indicator lamp shall light. Observe: Switch indicator lamp shall be off, when key switch or running control switch is on OFF position.	No: Go on next inspection. Yes: Consult your local agent.	

(20-5)

Inspection of hydraulic system

Inspection of hydraulic pump performance	<p>Note: If hydraulic oil temperature is lower than working temperature, firstly preheat hydraulic oil till feel that loading and digging cylinders being to warm up.</p> <p>Set loading bucket on flat ground and engage parking brake.</p> <p>Driver's seat faces to front of machine.</p> <p>Run engine at idle speed.</p> <p>Measure how long it will take to lift loading device to maximum height (Including setting bucket level).</p> <p>Observe: Whether loading bucket can be lifted to maximum height within 15s?</p> <p>Note: Lift loading bucket to maximum height for 3 times and calculate average lifting time. The basic performance of main pump can be determined.</p>	<p>No: Go on next inspection.</p> <p>Yes: If lifting time is too long, please refer to instruction in troubleshooting chapter: hydraulic system "Hydraulic functions act slowly". Consult your local agent.</p>
--	---	---

Inspection of vibration reduction of oil cylinder	<p>Lift vehicle wheels from ground with support legs.</p> <p>Lower movable arm from transporting position.</p> <p>Engine runs at about 1500rpm. Turn digging device left and right.</p> <p>Take notice of time and speed when oil cylinder reaches its end of stroke.</p> <p>Observe: Whether movement of bucket arm becomes slowly when reaching its end of stroke?</p> <p>Listen: Whether hear sound of hydraulic oil flowing through damping hole when bucket arm reaches its end of stroke?</p> <p>Recheck through function of movable arm for digging.</p> <p>Note: Oil cylinder for bucket arm is not equipped with damping device.</p>	<p>No: Go on next inspection.</p> <p>Yes: Disassemble and repair oil cylinder damping device. Consult your local agent.</p>
---	---	---

Inspection of support leg cylinder and hydraulic lock	<p>Engine runs at about 1500rpm. Lift loading bucket from ground with support legs.</p> <p>Lower support leg cylinder and lift rear of machine from ground.</p> <p>Observe/feel: Whether oil cylinder extends smoothly and jack up machine?</p>	<p>Yes: Go on next inspection.</p> <p>No: When cylinder floating up and down, check locking device. If</p>
---	---	--

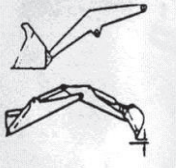
			cylinder goes do quickly, consult your local agent.
Inspection of subsidence of loading and digging devices		Note: Temperature of digging bucket cylinder is 38~52°C; otherwise, hydraulic oil shall be preheated.	No: Go on next inspection. Yes: Firstly determine which section subsides. Consult your local agent.
	<p>Fully extend digging device, digging bucket and ground forms angel of 45°. Movable arm drops till bucket edge keep away from ground by 50mm.</p> <p>Position loading bucket and bucket at the same height.</p> <p>Run engine at idle speed and observe bucket edge.</p> <p>Observe: Whether bucket edge touches with ground within 1 second?</p>		

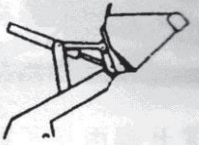
Inspection of connecting rod leveling bucket		Note: Bucket leveling function is effective only during lifting process of movable arm.	Yes: Go on next inspection. No: Adjust connecting rod of loading control valve. Consult your local agent.
	<p>Bucket can be set level manually after bucket lowering. Set loading bucket at bucket retracting position, movable arm closes up to ground.</p> <p>Lift loading device, meanwhile keep control lever on bucket retracting position.</p> <p>Observe control levers of bucket and loading device during lifting process.</p> <p>Observe/feel: Whether control lever of loading device moves to bucket unloading position and slowly perform bucket unloading function? After performing bucket unloading function, position of bucket keeps unchanged during the following lifting process of movable arm?</p>		

(20-6)

Checking operational condition of accessories

Inspection of switch for head lamp	Set key switch at ON position. Press switch on operating console for head lamp. Observe: two head lamps, two small lamps, two fog lamps light or not.	Yes: Go on next inspection. No: Check fuses and bulbs. Refer to “Working lamps do not light” in instrument and indicator lamp of troubleshooting chapter. Consult your local agent.
------------------------------------	---	--

Inspection of switch for back light	Set key switch at ON position. Press switch on operating console for back light. Observe: Whether back light lights?	Yes: Go on next inspection. No: Check fuses and bulbs as well as circuits. Consult your local agent.
-------------------------------------	--	---

Inspection of steering signal lamp	Set key switch at ON position. Press right side of switch for steering signal lamp. Observe: Whether front and rear yellow steering signal lamps light? Right indicator lamp on top of steering column jacket lights? Press left side of switch for steering signal lamp. Observe: Whether front and rear yellow left steering signal lamps light? Left indicator lamp on top of steering column jacket lights?	Yes: Go on next inspection. No: Check fuses and circuits. Consult your local agent.
------------------------------------	---	--

Inspection of horn	Set key switch at ON position. Press horn button. Listen: Whether horn sounds?	Yes: Go on next inspection. No: Check fuses and circuits. Consult your local agent.
--------------------	--	--

(20-7)

Checking parts and components in driver's cab

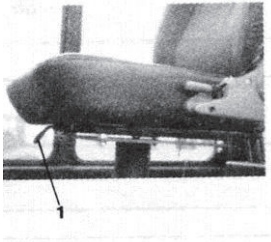
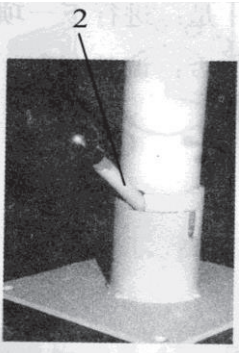
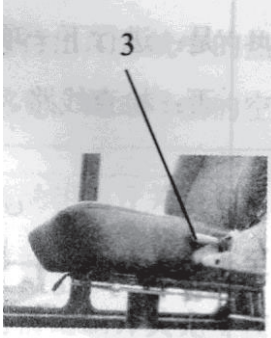
Inspection of connecting rod for seat control		Lift control handle (1). Move seat backward and forward and loosen control handle. Observe: Whether	Yes: Go on next inspection. No: Repair control connecting rod. Consult your local agent.
	handle can move freely and lock seat on desired position?		
Inspection of seat turning control mechanism		Lift handle (2). Position seat on desired position and lock. Feel: Whether control handle can move freely and lock seat on desired position?	Yes: Go on next inspection. No: Lubricate or repair control connecting rod. Consult your local agent.
Inspection of seat backrest control mechanism		Lift handle (3). Position seat on desired position and lock. Feel: Whether control handle can move freely and lock seat on desired position?	Yes: Go on next inspection. No: Lubricate or repair control connecting rod. Consult your local agent.
Driver's cab left door lock pin and opener	Open vehicle door lock pin. Observe vehicle door opening. Close vehicle door and lock its lock pin. Feel: Whether lock pin can be opened and closed freely?		Yes: Go on next inspection. No: Adjust vehicle doors. Consult your local agent.
Rear vehicle window lock pin and opener	Squeeze lock pins on both sides of middle window at rear upside. Jam vehicle window on groove on each sides. Observe vehicle door opening. Observe: When vehicle window is on lifting position, whether lock hook locks vehicle windows and will not bend vehicle windows.		Yes: Go on next inspection. No: Check and find faulty parts. Consult your local agent.

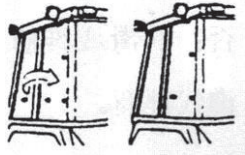
Inspection of vehicle windows		Open left and right rear vehicle windows. Fix rear window on front window. Observe: Whether	Yes: Go on next inspection. No: Adjust vehicle windows. Consult your local agent.
	sleeve gasket on rear window aligns with knob on front window? Observe/feel: Whether window hinge moves freely? After closing vehicle windows, locking tension of different lock pins is equal?		

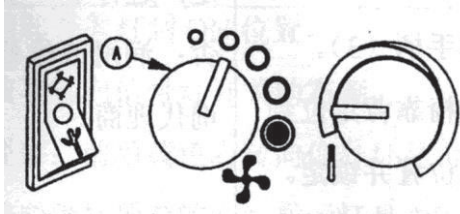
Inspection of fan motor (If equipped)		Stop engine, set key switch at ON position. Turn fan switch to Gear 1, 2, 3 and 4. Feel/listen: Whether fan has 4 gears? Whether air is exhausted through air outlet?	Yes: Go on next inspection. No: Check circuits. Consult your local agent.

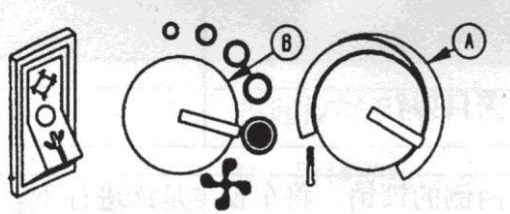
Heater (If equipped)		Start engine and run it idly at high speed. Waiting for 2 minutes. Turn switch (A) for heater to maximum temperature position. Turn fan switch (B) to maximum speed position. Feel: Whether air exhausted from air outlet is warm gas?	Yes: Go on next inspection. No: Consult your local agent.

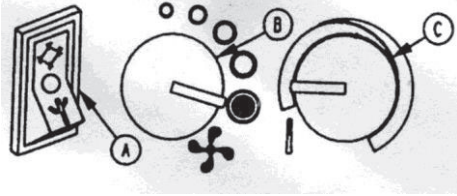
<p>Air conditioner (If equipped)</p>		<p>Yes: Go on next inspection.</p> <p>No: Consult your local agent.</p>
<p>Start engine and run it idly at high speed. Waiting for 2 minutes. Turn switch (A) for air conditioner to ON position. Turn fan switch (B) to maximum speed position. Turn fan switch (B) to maximum speed position. Turn temperature switch (B) to refrigerating position. Wait for hot air exhausting from air outlet system. Feel: Whether air exhausted from air outlet is cold gas?</p>		

<p>Inspection of front rain wiper</p>	<p>Turn key switch to ON position. Press switch of rain wiper to gear 1, middle position. Press switch of rain wiper to the end. Press switch of rain wiper to OOF position. Observe: whether front rain wiper has two working speeds? Observe: Front rain wiper shall return to stop position.</p>	<p>Yes: Go on next inspection.</p> <p>No: Check fuses and front rain wiper. Consult your local agent.</p>
---------------------------------------	---	---

<p>Inspection of overhead light</p>	<p>Turn key switch to ON position. Press switch of overhead light ON position. Observe: Whether overhead lamp lights?</p>	<p>Yes: Go on next inspection.</p> <p>No: Check fuses and bulbs as well as circuits. Consult your local agent.</p>
-------------------------------------	---	--

Other inspections

<p>Inspection of lock pins for transportation of digging device</p>	<p>Lift movable arm, turn it to transporting position. Take off turning lock pin and mount it rear frame and lower lock hole to fix it on vehicle frame. Observe: Whether turning lock pin can be assembled and disassembled freely?</p>	<p>Yes: Complete operating test inspection.</p> <p>No: Repair or replace lock pin. Check pin columns for burr and other failure. Consult your local agent.</p>
---	--	--

Troubleshooting

(21-1)

Analysis of trouble in diagnostic list is from an easy problem to a difficult one.

In trouble diagnosis, the following procedures should be noticed:

Procedure 1: Operational testing check

Procedure 2: Troubleshooting list

Procedure 3: Adjustment and/or testing

Procedure 4: Consult your local agent

(21-2)

Engine		
Phenomenon	Trouble	Corrective measure
Engine cannot be started or with difficulty	There is no diesel oil in diesel engine	Check fuel level
	Venthole of fuel tank is blocked	Remove fuel tank cover and hear sound of air entering fuel tank. Replace fuel tank cover.
	Electromagnetic valve of oil injection pump is not switched on	Turn key switch to "ON" position. Click should be heard inside oil injection pump. Replace fuse, examine and repair circuit.
	There is water in fuel or water frozen in fuel pipeline	Drain water from fuel tank. Check if there is water in fuel filter. Replace oil filter.
	There is impurity in fuel or fuel grade is improper	Check if there is impurity in filter element at fuel tank outlet, check if there is impurity at fuel tank bottom and clean fuel tank. Add fuel. Check if fuel grade is correct (Refer to Chapter Fuel and lubricating oil)
	Oil intake side of fuel system leaks	Check if there is bubble in oil filter, tighten up joints. Check if fuel pipeline is damaged.
	Diaphragm of fuel supply pump leaks	Check if fuel is admixed into engine oil.
	Starting speed is slow	Check battery and

		connection. Check if engine oil meets the requirement (cold day).
	Air cleaner is limited	Check air cleaner. Clean.
	Metering valve of oil injection pump is jammed	If engine has been started, tap oil injection pump. Replace metering valve. Consult your local agent
	Powerdown with trouble	Check powerdown electromagnetic valve. Consult your local agent
	Oil injection pump timing is improper	Consult your local agent
	Oil injection pump	Consult your local agent
	Oil injection nozzle	Disassemble and test oil injection nozzle. Consult your local agent
	Damaged piston ring or low compression ratio	Consult your local agent
	Cylinder end cushion leaks	Consult your local agent
Engine surges or frequently stalls	There is air in fuel	Check oil filter, search proof of air in fuel. Tighten up joints and drain air from fuel system.
	Venthole of fuel tank is blocked	Remove oil tank cover and hear the sound of air entering oil tank. Replace oil tank cover.
	There is impurity in fuel or fuel grade is improper	Check if there is impurity in filter element at fuel tank outlet, check if there is impurity at fuel tank bottom and clean fuel tank. Add fuel. Check if fuel grade is correct.
	There is water in fuel or water frozen in fuel pipeline	Drain water from fuel tank. Check if there is water in fuel filter. Replace oil filter.
	Fuel filter is blocked	Replace oil filter
	Oil return pipeline from oil injection pump to fuel tank is limited	Consult your local agent
	Oil injection pump timing	Consult your local agent

	is improper	
	Check if oil return joint on the top of control valve of oil injection pump is blocked	
	Metering valve of oil injection pump is jammed	Consult your local agent
	Engine is overheated	Consult your local agent
	Fuel supply pump	Consult your local agent
	Oil injection pump	Consult your local agent
	Oil injection nozzle	Consult your local agent
	Air valve clearance is improper	Check and adjust air valve clearance
	Air valve is jammed or burned out	Consult your local agent
	Damaged piston ring or low compression ratio or cylinder end cushion leakage	Consult your local agent
Power loss of engine	There is air in fuel	Check oil filter, search proof of air in fuel. Tighten up joints and drain air from fuel system.
	There is impurity in fuel or fuel grade is improper	Check if there is impurity in filter element at fuel tank outlet, check if there is impurity at fuel tank bottom and clean fuel tank. Add fuel. Check if fuel grade is correct.
	Idling speed is too low	Consult your local agent
	Oil injection timing is improper	Consult your local agent
	Adjustor trouble of oil injection pump or metering valve is jammed	Consult your local agent
	Engine is overheated	Consult your local agent
	Air valve clearance is improper	Consult your local agent
	Bent ejector rod	Consult your local agent
	Cylinder end cushion leaks	Consult your local agent
	Air valve is jammed or burned out	Consult your local agent
	Piston ring is damaged	Consult your local agent

	Fuel injection pump	Consult your local agent
	Oil injection nozzle is blocked	Consult your local agent
Engine cannot produce power	Filter element of fuel tank outlet is blocked	Check if there is water or impurity in fuel tank, remove water or impurity and clean.
	Fuel filter is blocked	Replace oil filter
	Fuel grade is improper	Add fuel with correct grade after draining the fuel
	Air system is limited	Check throttle valve of air cleaner and air cleaner. Clean.
	High-speed idling speed is too low or connecting-rod is improperly adjusted	Consult your local agent
	Air valve clearance is improper	Adjust air valve clearance
	Oil return pipeline or joint of oil injection pump is limited	Consult your local agent
	Oil supply valve trouble	Consult your local agent
	Fuel pipeline is limited	Consult your local agent
	Brake system is too lagged	Consult your local agent
	Bridge inside is too delayed	Consult your local agent
	Silencer is limited	Consult your local agent
	oil supply or adjustor trouble of oil injection bump	Consult your local agent
	Oil injection nozzle	Consult your local agent
	Compression ratio is low	Consult your local agent
	Camshaft is damaged	Consult your local agent
Engine emits too much black smoke or grey smoke	Air cleaner is limited	Check throttle valve of air cleaner and air cleaner. Clean or replace
	Fuel grade is improper	Add fuel with correct grade after draining the fuel
	Oil injection pump timing is improper	Consult your local agent
	Too much oil supply	Consult your local agent

	Oil injection nozzle	Consult your local agent
Engine emits too much blue smoke or white smoke	Starting speed is too low	Check battery and connection
	Fuel grade is improper	Add fuel with correct grade after draining the fuel
	Cold running of engine	Check thermostat. Consult your local agent
	Oil injection pump timing is improper	Consult your local agent
	Oil injection nozzle	Consult your local agent
	Compression ratio is low	Consult your local agent
	Excessive wear of cylinder cushion and/or jammed piston ring	Consult your local agent
Speedup is slow	Fuel grade is improper	Add fuel with correct grade after draining the fuel
	Oil injection nozzle	Consult your local agent
	Oil injection pump	Consult your local agent
Deflagration	Engine oil level is too low	Add engine oil
	Cold starting auxiliary fluid is jammed	Consult your local agent
	Oil injection pump timing is improper	Consult your local agent
	Temperature of cooling fluid is too low	Consult your local agent
Engine noise	Engine oil level or viscosity is low	Add proper engine oil to specified oil level
	Transmission joint of hydraulic pump is loose or damaged	Consult your local agent
	Fuel is admixed into engine oil	Check engine oil. Consult your local agent
	Fuel injection pump timing is improper	Consult your local agent
	Air valve clearance is too large	Adjust the clearance
	Bent ejector rod	Consult your local agent
	Rock arm shaft is damaged	Consult your local agent
	Loose connecting rod cover	Consult your local agent

	Loose main bearing cover	Consult your local agent
	Main bearing is damaged	Consult your local agent
	Connecting rod bearing is damaged	Consult your local agent
	Cam timing is improper	Consult your local agent
	There is scratch on piston	Consult your local agent
	Piston pin bushing or piston pin is damaged	Consult your local agent
Oil pressure is low	Oil level is low	Add proper engine oil to specified oil level
	Engine oil viscosity grade is improper or diesel oil is admixed into engine oil	Replace oil and consult your local agent
	Oil pressure switch or indicator light	Consult your local agent
	Oil pressure adjusting valve	Consult your local agent
	Oil intake filter screen of oil pump is blocked or damaged	Consult your local agent
	Transmission gear of oil pump is loose	Consult your local agent
	Oil pump gear or body case is damaged	Consult your local agent
	Clearance of main bearing, connecting rod or driven shaft is too large	Consult your local agent
	Cylinder body crack	Consult your local agent
	Inside oil duct leaks	Consult your local agent
Engine is overheated	Cooling fluid level is low	Add cooling fluid to cooling system and check if there is oil leakage
	Engine oil level is low	Add oil
	Fan belt is damaged or loose	Consult your local agent
	Overloaded engine or incomplete operating bumping post	Decrease load
	Fan	Consult your local agent
	Water tank is dirty or blocked	Consult your local agent
	Oil tank case trouble, clapboard damaged or	Consult your local agent

	trouble	
	Fuel grade is improper	Add fuel with correct grade after draining the fuel
	Water tank cover	Replace
	Temperature sensor trouble	Consult your local agent
	Oil injection pump timing is improper	Consult your local agent
	Thermostat trouble (jammed at the closing position)	Consult your local agent
	Thermostat trouble, cooling system is covered with calcium oxide	Consult your local agent
	Water pump	Consult your local agent
	Too much oil supply	Consult your local agent
	There is scratch on piston	Consult your local agent
Cold running of engine	Thermostat (jammed at the opening position)	Consult your local agent
Engine oil is admixed with cooling fluid or cooling fluid admixed with engine oil	Cylinder end leaks	Consult your local agent
	Cylinder sleeve leaks	Consult your local agent
	Crack occurs on Cylinder sleeve	Consult your local agent
	Oil cooler	Consult your local agent
	Crack occurs on cylinder body	Consult your local agent
Excessive fuel consumption	Air system is limited	Check throttle valve of air cleaner and air cleaner. Clean
	Fuel system leaks	Check. Repair.
	Fuel grade is improper	Re-add fuel with the specified grade
	Hydraulic unit overflows	Operating lever returns to mid position
	Setting value of system overflow valve is too high	Consult your local agent
	Oil injection pump timing is improper	Consult your local agent
	Oil injection nozzle	Consult your local agent

	trouble	
--	---------	--

(21-3)

Electrical equipment system		
Starting motor cannot run	Starting fuse	Check, and replace if necessary
	Red joint is loose	Check underside of loading control handle and compact joint
	Starter	
		Start relay
		Consult your local agent
	Key switch	Consult your local agent
	Battery	Consult your local agent
	Binding post of battery is eroded, loose or damaged	Consult your local agent
	Circuit	Consult your local agent
Starter electromagnetic valve emits sound of "click"	Joints of battery, earthing buttstrap or starter are poorly contacted or eroded	Check, clean and tighten up if necessary
	Battery voltage is low	Consult your local agent
Starting motor runs, but engine cannot be started	Driving gear does not enter flywheel ring gear of engine	Consult your local agent
	Flywheel gear is damaged	Consult your local agent
Starter starts slow	Loose or eroded battery wire	Check, clean or tighten up
	Loose earth connection of battery	Open battery cover, check and tighten up earth connection of battery
	Excessive load of power train	Depress disconnecting switch of clutch
	Excessive load of engine	Change with engine oil of proper grade, and temperature of engine oil shall be proper
	Battery voltage is low	Consult your local agent
Starting motor is in continuous running	Starter electromagnetic valve is jammed	Tap electromagnetic valve casing
	Starter is not cut off	Tap starting relay, and determine if switching

		rod of starter is jammed
	Starting relay is jammed	Tap starting relay, and determine if relay is jammed
	End	Consult your local agent
Starter starts with excessive noise	Gear ring teeth are damaged	Consult your local agent
	overrunning clutch skids.	Consult your local agent
	Starting motor	Consult your local agent
Water used by battery is too much	Crack occurs on battery body case	Replace battery
	Ambient temperature is high	Add distilled water
	Battery cell	Check if water level in each cell is identical
	Battery is overcharged	Consult your local agent
Crack occurs on battery body case	Without retaining clip of battery	Replace battery and install retaining clip
	Retaining clip of battery is loose	Replace battery and install retaining clip
	Retaining clip of battery is too tight	Replace battery and install retaining clip properly
	Battery is frozen	Battery shall be fully charged in cold day
Low output of battery	Water level is low	Add distilled water
	Top of battery is dirty or damp and causes discharge	Clean top of battery and keep it dry
	Battery wire is loose or eroded	Check and tighten up
	Binding post of battery is damaged	Manually twist binding post, if binding post is twisted, replace it
	Battery voltage is low	Consult your local agent
	Battery cell	Consult your local agent
	Excessive electrical load	Consult your local agent
	Improper specification of battery	Consult your local agent
	Excessive accessories	Consult your local agent
Engine noise	Engine support is worn	Remove belt, turn belt pulley and feel roughness of support

	Transmission belt	Check and replace if necessary
	Belt pulley is not rectified	Check
	Engine belt or fastening device is loose	Check and replace if necessary
	Diode	Consult your local agent
Indicator light of engine oil pressure is off	Instrument fuse	Replace fuse
	Indicator light	Turn key switch to open position. If indicator light is still off, replace bulb
	Circuit, joint or sensor	Earth yellow wire of sensor, and indicator light shall be on, or repair circuit or replace sensor
Indicator light of engine is off	Monitor/ instrument fuse	Replace fuse
	Indicator light	Turn key switch to open position. If indicator light is still off, replace bulb
Horn cannot emit sound	Earth horn	Earth horn to vehicle frame
	Horn fuse	Check and replace
	Horn	Replace horn
	Wiring harness	Consult your local agent
Rain strip does not work	Rain strip fuse	Check and replace
	Connection is loose or damaged	Check if circuit is broken and joint is loose. Repair
	Rain strip switch	Consult your local agent
	Rain strip motor	Consult your local agent
Driving lamp is off	Driving lamp fuse	Check and replace

(21-4)

Instrument and indicator light		
Pointer of fuel gauge does not move, indicator light is off and machine cannot be started	Startin relay fuse	Replace fuse
	Joint is poorly contacted or loose	Check underside of loading control handle and compact joint
	Earth wire is poorly contacted or loose	Check earth wire screw under loading control

		handle
Pointer of fuel gauge does not move, indicator light is off and machine can be started	Instrument fuse	Replace fuse
	Earth wire is poorly contacted or loose	Check earth wire screw under loading control handle
Start machine but it cannot be started	Fuel cut fuse	Replace fuse
	Oil injection circuit	Repair circuit
	Earthing electromagnetic valve	Repair earth wire
	Oil injection pump	Replace electromagnetic valve
	Poor earthing	Check and tighten
	Light switch	Consult your local agent
	Bulb is burned out	Replace bulb
Back light is off	Loose joint of wiring harness	Check and re-connect
Light is dim	Poor contact of light	Check and tighten
	Battery is undercharged	Check battery joint
	Output voltage of engine is low	Check belt tension and adjust
	Poor earthing of light	Check and tighten

(21-5)

Hydraulic system		
Oil tank drains oil when replacing oil filter	Venthole of oil return pipe inside oil tank is blocked	Disassemble, check and repair. Consult your local agent
	Venthole inside oil tank is damaged	Disassemble and repair. Consult your local agent
Loading or steering hydraulic device does not work	Oil level is low	Add oil to the specified oil level
	Transmission shaft trouble	Replace and Consult your local agent
	Oil pump trouble	Disassemble hydraulic oil filter and check. If there is a great deal of metal impurity inside oil filter, consult your local agent

	Oil circuit or valve trouble	Check if oil circuit is clipped or valve core is jammed. CONSULT your local agent
Hydraulic device of loading system does not work (steering is normal)	Overflow trouble of loading system	Check system overflow. CONSULT your local agent
	Power of loading hydraulic system is low	Overflow pressure setting of system is improper. CONSULT your local agent
	Oil leakage of working oil circuit	CONSULT your local agent
Hydraulic power is low	There is air in hydraulic oil	Oil grade is improper, re-add oil after oil drain. Oil intake hose leaks, check and tighten
	Oil leakage of working oil circuit	CONSULT your local agent
	Low oil level	Check oil level(See Chapter Fuel and lubricating oil)
	Overflow pressure setting of system is improper	CONSULT your local agent
Steering hydraulic device acts slowly	Priority valve	CONSULT your local agent
	Diversion valve leaks	CONSULT your local agent
	Steering cylinder leaks	CONSULT your local agent
	Steering connecting rod	Check and maintain. CONSULT your local agent
Steering hydraulic device does not work (loading device is normal)	Priority valve trouble	CONSULT your local agent
	Steering pressure regulating valve is worn	CONSULT your local agent
Machine travels slowly	Engine or transmission case trouble	CONSULT your local agent
	Hydraulic system is limited	CONSULT your local agent
Power descending range of engine is excessive in	Overflow pressure setting of system is too high	CONSULT your local agent

loading operations		
	Engine fails to reach the specified performance	Check engine performance, and CONSULT your local agent
Power descending range of engine is excessive in digging operations	Overflow pressure setting of system is too high	CONSULT your local agent
	Unloading trouble of oil pump	CONSULT your local agent
Digging device acts slowly (loading device is normal)	Flow of auxiliary pump is too low	Check flow of auxiliary pump, and consult your local agent
	Overflow pressure setting of unloading of oil pump is too low	CONSULT your local agent
	Electromagnetic valve trouble	CONSULT your local agent
	Control valve is worn	CONSULT your local agent
Hydraulic function acts slowly	Flow of oil pump is low	CONSULT your local agent
	Overflow of system leaks	CONSULT your local agent
	Low oil level	Add oil to the specified level. (See Chapter Fuel and lubricating oil)
	Rpm of engine is low	Increase rpm or check rotating speed of engine. (See instruction in this manual relevant to checking rotating speed of engine)
	There is air in hydraulic oil	Hydraulic oil is improper, add oil after draining the oil. Oil intake hose leaks, check and tighten (See Chapter Fuel and lubricating oil)
	Hose or oil pipe leaks	Check and tighten joints
	Overflow valve of system is jammed or leaks	CONSULT your local agent
Loading or digging action in some function is slow	Control valve plate trouble	CONSULT your local agent

	Control lever and connecting rod are improperly adjusted	Check lever and connecting rod and consult your local agent
	Overflow valve or plunger in control valve leaks	CONSULT your local agent
	Oil cylinder leaks	CONSULT your local agent
	Piston rod of oil cylinder is bent	CONSULT your local agent
Loading or digging device in some function is underpowered	Control lever and connecting rod are improperly adjusted	Check lever and connecting rod and consult your local agent
	Overflow valve or plunger in control valve leaks	CONSULT your local agent
	Oil circuit is bent or limited	Check and maintain
	Hydraulic control valve trouble	Disassemble, check and maintain. CONSULT your local agent
Loading and digging hydraulic device act slowly (low output of oil pump)	There is air in hydraulic oil	Hydraulic oil is improper, add oil after draining the oil. Oil intake hose leaks, check and tighten (See Chapter Fuel and lubricating oil)
	Overflow pressure setting of system is improper.	CONSULT your local agent
	Main pump	CONSULT your local agent
Hydraulic power is low (low hydraulic pressure)	Low oil level	Add oil to the specified level. (See Chapter Fuel and lubricating oil)
	There is air in hydraulic oil	Hydraulic oil is improper, add oil after draining the oil. Oil intake hose leaks, check and tighten (See Chapter Fuel and lubricating oil)
	Overflow valve of system is improperly adjusted	CONSULT your local agent
	Overflow valve of system is improperly set	CONSULT your local agent
	Working oil circuit leaks	CONSULT your local agent

	Hydraulic system seriously leaks	CONSULT your local agent
Hydraulic function with noise	Low oil level	Add oil to the specified level. (See Chapter Fuel and lubricating oil)
	There is air in hydraulic oil	Hydraulic oil is improper, add oil after draining the oil. Oil intake hose leaks, check and tighten (See Chapter Fuel and lubricating oil)
	Worn overflow valve in digging valve or oil circuit trouble	Consult your local agent
Function descends	Oil leakage through valve oil port	Consult your local agent
	Oil leakage through cylinder and valve	Consult your local agent
Control valve is jammed or action is retarded	Connecting rod or control valve is bent	Check and adjust connecting rod, consult your local agent
	Hydraulic system is overheated	Consult your local agent
	There is friction between return spring and spring cover	Consult your local agent
	Return spring is broken	Consult your local agent
	There is dirt in control valve	Disassemble and clean, consult your local agent
	There is scratch in	Consult your local agent
Hydraulic oil is overheated	Overburden	Reduce load
	Complete overflow of hydraulic system	Operating lever returns to mid position when not in operation
	Oil level in oil tank is too low	Add oil to the specified level. (See Chapter Fuel and lubricating oil)
	Hydraulic oil with low viscosity is used in hot day	Use the recommended oil (See Chapter Fuel and lubricating oil)
	Hydraulic cooling system is retarded	Clean water tank and area around oil cooler
	Overflow valve pressure of system is improperly set	Consult your local agent

	Priority valve trouble	Consult your local agent
	Oil cooler is blocked	Clean oil cooler
	Hydraulic system leaks excessively	Consult your local agent
Oil foams	Too low or high oil level	Check oil and adjust oil level to the specified oil level
	Hydraulic oil is improper	Use the recommended oil (See Chapter Fuel and lubricating oil)
	Oil intake side of oil pump leaks	Consult your local agent
	Fail to maintain oil	Perform proper maintenance measures. (See Chapter Regular maintenance)
Hydraulic pump leaks	Set screw is loose	Fasten to the specified torque. Consult your local agent
	Oil seal of shaft is worn	Consult your local agent
	Fire protection supporting gasket of oil pump is broken	Consult your local agent
	Hydraulic oil is overheated	Determine the reason of oil overheat. See this chapter "Hydraulic oil overheat"
Noise of oil pump is excessive	Oil level is low	Add oil to the proper level
	Bypass valve noise of hydraulic oil filter	Replace oil filter. Check, clean and repair
	Oil pump drive is worn	Consult your local agent
	Oil pipe contacts driver's seat. (Wear driver's cab, transmission case or shock absorber rubber of driver's shed)	Consult your local agent
	Fixing device of oil pump is loose	Fasten as required
	Oil leakage of hydraulic pipeline	Consult your local agent
Diversion valve cannot return to mid position	Return spring is damaged	Consult your local agent
	Diversion valve bushing is	Consult your local agent

	damaged	
Machine does not change direction when turning steering wheel	Low oil level	Check oil level of oil tank
	Outside leakage	Consult your local agent
	Priority trouble	Consult your local agent
	Diversion valve leaks	Consult your local agent
	Steering cylinder leaks	Consult your local agent
	Worn main pump	Consult your local agent
Machine steers to the reverse direction	Pipeline connection of steering cylinder is improper	Oil pipe of steering cylinder is connected to the reverse oil port
Vibration of steering wheel is excessive	Rotor of diversion valve fails to be rectified	Consult your local agent
Machine fails to change direction when diversion valve in mid position	Diversion valve leaks	Consult your local agent
	Fail to align steering column with diversion valve	Consult your local agent
Steering valve beats hands	Diversion valve leaks	Consult your local agent
Turn steering wheel with difficulty	Leakage of diversion valve or impurity of oil pipe	Consult your local agent

(21-6)

Transmission case		
Machine fails to move after engaging low speed or high speed gear	Low oil level of transmission case	Add oil to proper oil level
	Brake lag	Consult your local agent
	Fail to release parking brake	Consult your local agent
	Transmission spline of motor is worn or fails to engage with transmission shaft of transmission case	Consult your local agent
	Gear of oil pump is jammed	Consult your local agent
	Mechanical trouble in transmission case	Consult your local agent
	Shifting fork of gearshift or shaft of transmission case is damaged	Consult your local agent

	Transmission shaft is damaged	Check if transmission shaft and universal joint are damaged
Low efficiency of transmission case	Low oil level	Add oil
	Oil is improper	Change oil
	Oil leakage at speed-change control valve	Consult your local agent
	Oil pump wear cause low flow of speed change motor	Consult your local agent
	Moto is damaged	Consult your local agent
Machine is underpowered or moves slowly	Low oil level	Add oil to the proper oil level
	Oil is improper or there is air in oil	Change oil
	Brake lag	Consult your local agent
	High idle speed setting of engine is too high	Consult your local agent
	Low pressure of speed change system	Consult your local agent
	Clutch lag and clutch plate distortion	Consult your local agent
	Motor trouble	Consult your local agent
	Gearlever is improperly adjusted	Consult your local agent
	Low power of engine	Consult your local agent
	Mechanical trouble of transmission case or bridge inside	Consult your local agent
Transmission case is overheated	Oil level is too high or too low	Check and adjust oil level
	Oil is improper	Drain oil and re-add oil
	Airflow of radiator is retarded	Consult your local agent
	Lost clapboard, damaged fan casing or loose fan belt	Consult your local agent
	Radiator inside is retarded	Consult your local agent
	Oil flowing in and out of radiator is retarded	Consult your local agent
Excessive noise of power transmission system.	Idling speed of engine is too low	Check and adjust oil level

	Oil level is too low	Add oil to the proper oil level
	Parts of transmission case or bridge inside are worn or damaged	Consult your local agent
	Universal joint of transmission shaft is worn	Consult your local agent
	Parts of power train are not aligned	Consult your local agent
	There is no lubricating oil in lubricating pipeline	Consult your local agent
	Hydraulic pipeline touches parts of power train	Consult your local agent
	Assembly adjustment or setting is improper	Consult your local agent
Impact sound of gear is excessive in gearshift	Operating speed of gearshift is too high	See instruction in the operating manual
	Fail to disconnect motor in gearshift	Depress brake in gearshift
	Gearlever is worn or broken	Consult your local agent
	Synchronizing device trouble	Consult your local agent
Speed changing pressure of gear is low	Low oil temperature	Preheat to the specified oil temperature
	Low oil level	Add oil
	Oil filter is blocked	Check oil filter, replace
	Speed changing pressure is low, leaks	Consult your local agent
	Speed changing pump trouble	Consult your local agent

(21-6)

Driving front and rear axles		
Driving front and rear axles are not powered	Transmission shaft trouble	Consult your local agent, check and repair
	Half axis trouble of driving front axle	Consult your local agent
	Gear ring or driving gear trouble of driving front axle	Consult your local agent
	Gear transmission part trouble inside transmission case	Consult your local agent

One side wheels of driving front and rear axles are not powered		Consult your local agent
	Planet wheel rim is damaged	Consult your local agent
	Half axis trouble of driving front axle	Consult your local agent

(21-8)

Rear axle		
Working braking effect is not ideal	There is air in brake valve, brake pipeline or piston	Consult your local agent
	Brake valve leaks	Consult your local agent
	Oil seal of brake piston leaks	Consult your local agent
	Brake plate is seriously worn	Consult your local agent
	Brake pipeline is retarded	Consult your local agent
	Low oil level	Consult your local agent
Cannot release working braking	brake pedal cannot reset fully	Consult your local agent
	Brake plate distortion	Consult your local agent
	Brake piston is jammed	Consult your local agent
	Brake valve trouble	Consult your local agent
	Brake valve leaks	Consult your local agent
Cannot keep parking brake	Manual braking adjustment is improper or parts are damaged	Check and replace parts, consult your local agent
	Reversing lever is not in mid position	Reversing lever returns to mid position
Cannot release working braking	Pull rod of parking brake is over dead point	Consult your local agent

Storage of machine

(22-1)

Preparation before storage of machine

1. Repair worn or damaged parts. Install new parts when necessary so as not to delay

posterior operating time.

2. Loosen engine belt and fan belt.
3. Clean rough filter element of air filter.

Important instruction: high-pressure (over 1379 kPa) washing will damage newly sprayed top coating. Therefore only when sprayed paint has air dried for 30 days can parts and components, or whole machine be washed with high pressure.

4. Clean machine. Clean machine by low-pressure (below 1379 kPa) washing after arrival of goods for 30 days. Change printing when necessary.
5. Disassemble seat damping and other vulnerable parts.

Important instruction: it is forbidden to spray antirusting agent to painting surface.

6. Withdraw cylinder as possible, or paint antirusting agent on piston rod that fails to be withdraw.
7. Lubricate all lubricating points.
8. Lift machine as possible to make tyres leaving the ground. Or, park the machine on the hard road surface to avoid tyre freezing.
9. Store machine at dry and safe place and cover it with waterproof material.

Important instruction: to prevent other people from operating machine without permission to cause damage, please hang the warning board “No operating” on the steering wheel.

10. Hang the warning board “No operating” on the steering wheel.
11. Remove key and lock all doors of the vehicle.

Monthly storage procedure

▲ Warning: Gas emitted from engine is harmful to human body, therefore engine shall be started at places with excellent ventilation.

1. Drain water and impurity when temperature is below 0 °C.
2. Clear away antirusting agent painted on the surface of piston rod with cleaning agent.

▲ Important instruction: to prevent damage of engine, fluidity of engine oil on oil scale shall be checked in cold day, engine cannot be started when oil fluid becomes wax or jelly, and at this time, crankshaft shall be heated by outside heat until engine oil becomes liquid.

3. Check all oil levels, if oil level is low, check leakage and add oil as required.
4. Check belt.
5. Check conditions of all hoses and joints.
6. Check electrolyte level, when necessary charge and install battery.
7. Check tyre condition and tyre pressure.
8. Add fuel.(See Chapter Fuel and Lubricating oil).
9. Lubricate turbocharger bearing:
 - Disconnect fuel cut-off fuse.

- Start the engine continuously for 10s.
 - Connect fuel cut-off fuse.
10. Start the engine and run at the rotary speed of 1/2 for 5 minutes. It is forbidden to run the engine at high speed or idling speed.
 11. Fuel system exhausts. If engine cannot be started or running is not ideal after being started, change fuel filter. Fuel system exhausts again.
 12. Make sure there is nobody around machine, and repeat functions of loading movable arm, bucket, digging movable arm, bucket, bucket arm and return for 3 times.
 14. Withdraw piston rod of cylinder and park the machine.
 15. Apply antirusting agent on the piston rod that fails to withdraw.

(22-2)

Technical Parameters of Site Wizard - A Backhoe					
1. Overall dimensions			5. Engine		
1	Overall dimensions (mm)	6150*2350*3763	1	Model	Yuchai Power 4105T
2	Wheelbase (mm)	2290	2	Type	Turbocharger
3	Wheel track (mm)	1950	3	Rated power (KW)	85
4	Minimum ground clearance (mm)	320	4	Rated speed (r/min)	2400
5	Minimum turning radius (mm)	6580	5	Cylinder number-inner diameter	4-105
2. Performance parameters			6. Transmission system		
1	System pressure (Mpa)	28	1	Gearbox	Hydraulic shift
2	Machine weight (kg)	8200/8500	2	Number of gears	2 forward and 2 backward
3	Maximum speed (km/h)	28/38	3	Torque Converter	YJ280
4	Maximum climbing ability (°)	35			
3. Digging parameters			7. Axle		
1	Maximum telescopic digging depth (mm)	4000/5200	1	Type	First-stage wheel reduction bridge
2	Maximum digging radius (mm)	4800/6000	8. Tires		
3	Maximum lifting height (mm)	5200/5950	1	Specification	14-17.5/19.5L-24
4	Bucket capacity (m3)	0.3	2	Service brake	Air-over-oil caliper brake
5	Excavator rotation angle (°)	190	3	Parking brake	Air brake
6.	Bucket width(mm)	600	9. Oil volume		

4. Loading parameters			1	Fuel tank (L)	100
1	Maximum dumping height (mm)	2742	1	Hydraulic oil tank (L)	100
2	Maximum dumping distance (mm)	1062	10. Others		
3	Bucket capacity (m3)	1	1	Drive type	Four-wheel drive
4	Rated Load(t)	2.5	1	Speed type	Hydraulic shift
			2	Control system	Electromagnetic hydraulic pilot control
	The specific parameter changes are subject to the actual product.				