

DIGGERKING

King

T30

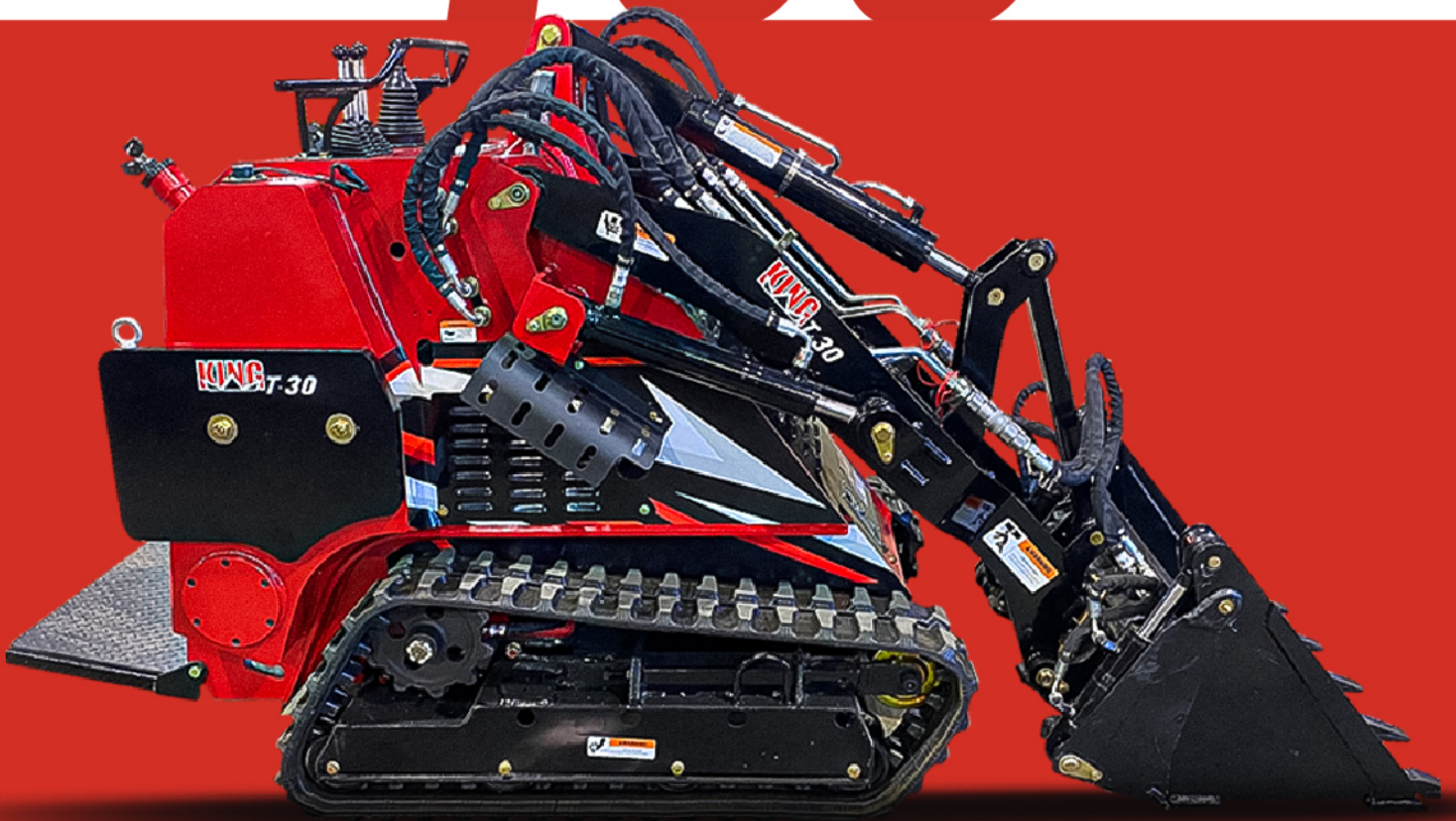

OPERATOR'S MANUAL

DIGGERKING.COM.AU

TABLE OF CONTENTS

TABLE OF CONTENTS	3
Intended Use.....	4
Technical Specifications	4
Important Safety Information	4
PRODUCT USE AND CARE	5
Safety and Product Labels.....	9
Before Each Use	10
Adding Fuel:	11
Filling the fuel tank:.....	11
Checking oil level:.....	11
Check hydraulic fluid:	11
Pre-Start Inspection	12
Operating Instructions.....	13
Drive Control Levers:.....	13
Starting and stopping the Engine	15
Attachments.....	16
After Each Use.....	17
Transporting and securing	17
Moving a Non-functioning machine.....	17
Maintenance	18
Bushes:.....	19
Engine Oil	19
Changing Oil Filter	19
Fuel Filter	19
Fuel Tank.....	20
Hydraulic system	20
Battery	21
Cleaning and long-term storage.....	22
Maintenance Log.....	23
Troubleshooting	27

Intended Use

This unit is used for trenching, digging, carrying materials, demolition, site preparation, utility installation, sweeping and more, designed for short runs and operation in limited- access spaces. It could be equipped with various attachments for light and medium duty work.

Technical Specifications

Property	Specification
Overall width (with bucket)	930mm
Overall length	2650mm
Overall height	1370mm
Maximum Operating Height (with standard bucket)	2052mm
Operating weight	1380kg
Rated loading capacity – bucket	400kg
Travel Speed	0-5km/h
Angle of departure	22°
Engine	25HP
Ground clearance	104mm
System relief pressure (hydraulic)	18MPa
Hydraulic oil tank capacity	33 liters
Standard bucket capacity	0.17CBM

* Specifications and design subject to change without notice.

Important Safety Information

WARNING

- Read and understand all instructions. Failure to follow all instructions may result in serious injury or property damage.
- The warnings, cautions, and instructions in this manual cannot cover all possible conditions or situations that could occur. Exercise common sense and caution when using this machine. Always be aware of the environment and ensure that the machine is used in a safe and responsible manner.
- Do not modify this machine in any way. Unauthorized modification may impair the function and/or safety and could affect the life of the machine. There are specific applications for which the machine was designed.
- Use the right tool for the job. DO NOT attempt to force small equipment to do the work of larger industrial equipment. There are certain applications for which this equipment was designed. This machine will be safer and do a better job at the capacity for which it was intended. DO NOT use this equipment for a purpose for which it was not intended.
- Industrial or commercial applications must follow OHS requirements.

⚠ WARNING

- To reduce your exposure to chemicals: work in a well-ventilated area, and work with approved safety equipment, such as dust masks that are specially designed to filter out microscopic particles.
- Handling power cords on corded products may expose you to lead. Wash your hands after handling.

⚠ WARNING

WORK AREA SAFETY

- Inspect the work area before each use. Keep work area clean, dry, free of clutter, and well-lit. Cluttered, wet, or dark work areas can result in injury. Using the machine in confined work areas may put you dangerously close to cutting tools and rotating parts.
- Do not use the machine where there is a risk of causing a fire or an explosion, e.g., in the presence of flammable liquids, gases, or dust. The machine can create sparks, which may ignite the flammable liquids, gases, or dust.
- Do not allow the machine to come into contact with an electrical source. The machine is not insulated, and contact will cause electrical shock.
- Keep children and bystanders away from the work area while operating the machine. Do not allow children to handle the machine.
- Be aware of all power lines, electrical circuits, water pipes, and other mechanical hazards in your work area. Some of these hazards may be hidden from your view and may cause personal injury and/or property damage if contacted.

⚠ CAUTION

PRODUCT USE AND CARE

- Do not force the machine. Machines are safer and do a better job when used in the manner for which they are designed. Plan your work and use the correct machine for the job.
- Check for damaged parts before each use. Carefully check that the machine will operate properly and perform its intended function. Replace damaged or worn parts immediately. Never operate the machine with a damaged part.
- Do not use a machine with a malfunctioning switch. Any power tool that cannot be controlled with the power switch is dangerous and must be repaired by an authorized service representative before using.
- Disconnect the power/air supply from the machine and place the switch in the locked or off position before making any adjustments, changing accessories, or storing the machine. Such preventive safety measures reduce the risk of starting the machine accidentally.
- Store the machine when it is not in use. Store it in a dry, secure place out of the reach of children. Inspect the machine for good working condition prior to storage and before re-use.
- Use only accessories that are recommended by the manufacturer for use with your machine.
- Accessories that may be suitable for one machine may create a risk of injury when used with another machine. Never use an accessory that has a lower operating speed or operating pressure than the machine itself.
- Keep guards in place and in working order. Never operate the machine without the guards in place. Do not leave the machine running unattended.

⚠ WARNING

PERSONAL SAFETY

- Stay alert, watch what you are doing, and use common sense when operating the machine. Do not use the machine while you are tired or under the influence of drugs, alcohol, or medication. A moment of inattention while operating the machine may result in serious personal injury.
- Dress properly. Do not wear loose clothing, dangling objects, or jewelry. Keep your hair, clothing and gloves away from moving parts. Loose clothes, jewelry, or long hair can be caught in moving parts. Air vents on the machine often cover moving parts and should be avoided.
- Wear the proper personal protective equipment when necessary. Use safety goggles (not safety glasses) with side shields, or when needed, a face shield. Use a dust mask in dusty work conditions. Also use non-skid safety shoes, hardhat, gloves, dust collection systems, and hearing protection when appropriate. This applies to all persons in the work area.
- Do not overreach. Always keep proper footing and balance.
- Remove keys or wrenches before connecting the machine to an air supply, power supply, or turning on the machine. A wrench or key that is left attached to a rotating part of the machine may cause personal injury.
- Secure the work with clamps or a vise instead of your hand when practical. This safety precaution allows for proper tool operation using both hands.

Specific Operation Warnings

⚠ WARNING

- Do not allow any passengers on any part of equipment, including buckets and operating platform. Do not refuel with engine running, or while you or someone nearby is smoking.
- Do not operate any of the control levers (including auxiliary lever) unless you are standing with both feet on the platform and firmly holding the grip handles.
- Do not place feet under the platform.
- Watch where you are driving. Always look down and behind, before and while reversing.
- Engine exhaust contains Carbon Monoxide, which is an odorless, deadly poison. Carbon Monoxide can kill you. Do not run engine indoors or in a confined space.
- Always lower loader arms and/or place attachment on the ground when parking or leaving the equipment unattended. Always stop the engine if leaving the operators platform.

- Do not carry a load or heavy attachment with the loader arms in a raised position. Do not step off the platform with a load raised.
- Never jerk the control levers. Use a steady motion. Slow down before turning. Sharp turns may cause loss of control.
- Stop the engine before making any adjustments to the attachments or the machine. Never weld on or near the fuel tank whether it is empty or full.
- Do not operate on or near embankments. Look out for ditches, holes, etc. and beware of traffic when near roads.
- Operate only in daylight or good artificial lighting.
- Do not operate the machine while under the influence of alcohol or drugs.
- Use extra care while loading or unloading the equipment onto a trailer or truck.
- Do not touch equipment or attachment parts that may be hot from operation.
- Allow to cool before attempting to maintain, adjust or service.
- Do not allow children to play on the machine.

Operating on Slopes:

- Do not operate on slopes exceeding 15°. If the slope is greater than 5° only go up and down (not across).
- Always have the heavy end of the machine uphill. Weight distribution will change. An empty bucket will make the rear of the machine heaviest; a loaded bucket will make the front of the machine heaviest. Various attachments will change which end is heaviest. If you are unsure, phone us and ask. These same rules apply when loading and unloading the equipment onto a trailer or truck.
- Avoid turning on slopes. If you must turn, turn slowly keeping the heavy end of the machine uphill.
- Do not operate near ditches or embankments, the machine could turn over if a wheel goes over the edge of a cliff or ditch or the edge caves in
- Do not operate on wet grass, reduced traction could cause slip.
- Remove obstacles such as rocks, tree limbs, etc. from the work area. Watch for ruts or bumps as uneven terrain could overturn the machine. Tall grass can hide obstacles.
- Operate in slow speed. Put pump selector valve in slow (turtle) position so that you will not have to stop or shift while on the slope.
- If parking on slopes or hillsides always lower the loader arms and attachment to the ground and chock the wheels.
- If machine becomes unstable, jump clear. Never try to stabilize the machine by putting your foot on the ground.

Service:

- Before performing any service, repairs, maintenance or adjustment, stop the engine and remove the key.
- Never run the machine in an enclosed area.
- Perform all maintenance with the loader arms fully lowered. If loader arms need to be raised to perform tasks, secure them in the raised position by using cylinder locks or a safety stand.
- Keep nuts and bolts tight.
- Do not tamper with safety devices. Before each use check safety systems properly.
- Keep the machine free of grass, leaves, or other debris build-up. Clean up oil or fuel spillage. Allow machine to cool before storing.
- Use extra care when handling petroleum and other fuels. They are flammable and vapors are explosive.
 1. Use only an approved container.
 2. Never remove the fuel cap or add fuel while the engine is running. Allow engine to cool before refueling. Do not smoke.
 3. Never refuel the machine indoors.
 4. Never store the machine or fuel container inside where there is an open flame, such as near a water heater or furnace.
 5. Never fill a container while it is inside a vehicle, car boot, utility tray or any surface other than the ground.
 6. Keep container nozzle in contact with the tank during filling.
- Stop and inspect equipment if you strike anything or hear any strange noise coming from the machine. If necessary, repair machine before starting again.
- Use only genuine replacement parts to ensure that original standards are maintained.
- Battery acid is poisonous and can cause burns. Avoid contact with skin, eyes, and clothing. Your face, eyes, and clothing should be protected when working with a battery.
- Battery gases can explode. Keep cigarettes, sparks and flames away from battery.
- Hydraulic pressure escaping under pressure can penetrate the skin and cause injury. Keep hands and body away from pin hole leaks or nozzles that eject high pressure hydraulic fluid. A small leak can be dangerous. To find hydraulic leaks, use cardboard or paper.

Safety and Product Labels

Reference Number	Description	Quantity
1	Burn Hazard Warning Decal	1
2	Crush Hazard (Hand) Warning Decal	2
3	Crush Hazard (Body) Warning Decal	2
4	High-Pressure Fluid Hazard Warning Decal	3
5	Crush Hazard (Hand, Track) Warning Decal	2
6	Fire Hazard Danger Decal	1
7	Rotating Parts Warning Decal	1
8	Crush Hazard (Body, Access Panel) Warning Decal	1
9	Operational Warnings Decal	1



1



2



3



4

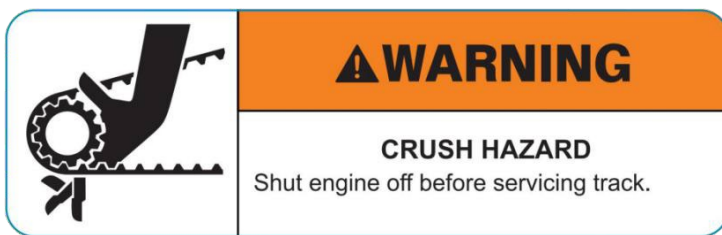

5

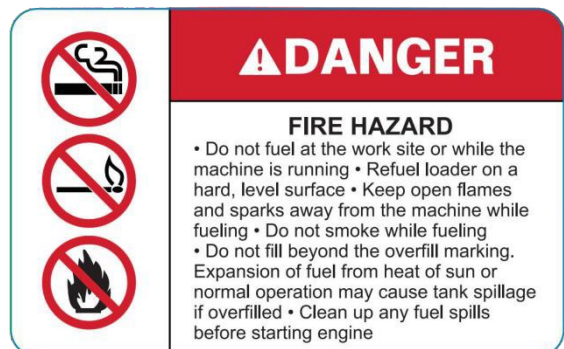

6



7



8

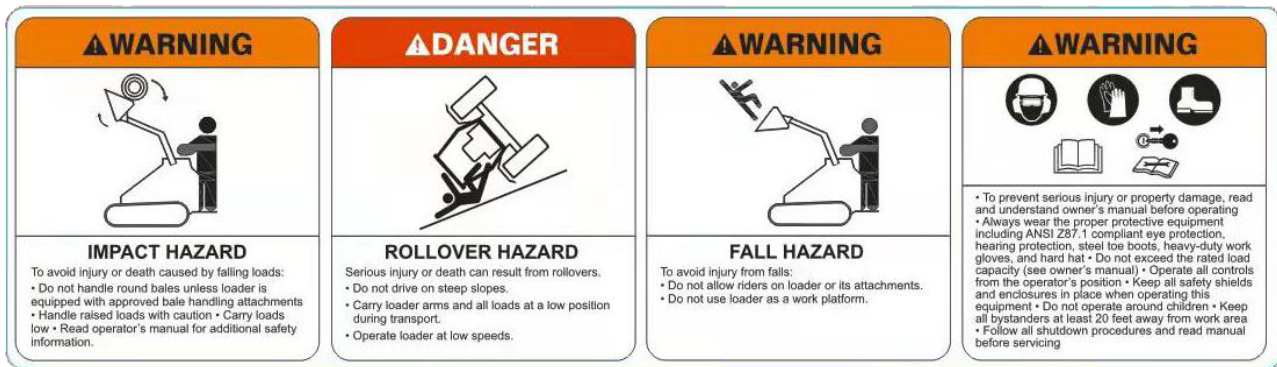

9

Before Each Use

⚠ WARNING

Use a funnel and fill the fuel tank outdoors, in an open area, when the engine is cold. Clean up any petrol spills.

Do not completely fill the fuel tank.

Never smoke while handling fuels and stay away from an open flame or any place that a spark may ignite petroleum fumes.

Store fuels in an approved container, out of reach from Children.

Read this manual completely.

Always check the following before operation:

- Fuel level;
- Ensure breather on top of the fuel cap is open;
- Engine oil level;
- Remove all refuse from the machine;
- Be sure that the work area is free from other people and children;
- Clear debris in work area. Know and mark the location of any utility lines.

Adding Fuel:

Labelling on the fuel tank tells whether a machine requires petroleum or diesel fuel.

Filling the fuel tank:

1. Position machine on level surface, lower the loader arms and turn off the engine (turn ignition key to off).
2. Remove the key.
3. Clean around the fuel tank cap and remove the cap. Use a funnel to add fuel as specified above to the fuel tank, filling until the fuel reaches 60-70mm below the top of the tank. This space is needed to allow the fuel to expand. Do not fill the fuel tank completely full.
4. Replace the fuel cap securely. Clean away any fuel that may have spilt.

Checking oil level:

IMPORTANT: Overheating will result if the engine is operated with a blocked grass screen, dirty or plugged cooling fins, and/or cooling shrouds removed.

1. Remove debris from the machine
2. Park the machine on a flat surface, lower the loader arms and turn off the engine (turn ignition key to off).
3. Remove the key.
4. Check the air filter precleaner for debris. If required, wipe away debris before and during each use. Debris can build up in the engine area. Clean any debris build-up with a brush or blower before each use.

IMPORTANT: It is preferable to blow out dirt than to wash it out. If water is used, keep it away from electrical appliances.

IMPORTANT: Do not high-pressure wash. High-pressure washing can damage the electrical system.

Check hydraulic fluid:

Check the hydraulic fluid level before engine is started and after every 25 hours of operation.

Fluid type: H46 or equivalent.

Hydraulic tank capacity: 33 liters.

1. Position machine on level surface. Lower the loader arms and stop the engine. Clean area around filler neck of hydraulic tank.
2. Remove cap from filler neck and check fluid level. Fluid level should be approximately 75-100mm below the
3. top of the tank.
4. If level is low, add enough fluid to rise to proper level.
5. Install cap on filler neck.

Pre-Start Inspection – Daily Check

It is very important to do a visual inspection of the machine before beginning operation.

This inspection should include:

- Check all decals and warning signs for damage.
- Check engine oil.
- Check and refill fuel tanks.
- Check hydraulic lines and hoses for signs of damage or leaks.
- Inspect the machine for any signs of damage or loose fasteners.
- Check fluid levels and any signs of leaking fluid.
- Do all Daily Service Checks.
- Check machine controls to make sure that they automatically return to the neutral position. The following information presents details on these inspection points and service checks.

Activity	Daily (10 Hours)
Fuel	Check and fill
Engine Oil	Check and fill if low
Engine Oil Filter	Inspect for leaks
Engine Radiator	Inspect add if necessary
Air Filter	Check air filter dirt release
Fuel Filter	Inspect for leaks
Battery	Inspect terminals/leaks
Hydraulics - Hydraulic Filter - Hydraulic Fluid - Hydraulic Hoses	Inspect for leaks Check and fill if low Inspect for leaks Inspect for leaks/cracks/damage
Grease	Check
Track Damage	Inspect
Visual Check for Loose/Missing Fasteners	Inspect
Check and Adjust Track Tension	Inspect
Check both Track Widening Stop Bolts	Inspect

Operating Instructions

⚠ WARNING

- Do not operate any of the control levers (including auxiliary lever) unless you are standing with both feet on the platform and firmly holding the grip handles.
- Do not operate or drive machine on roadways

Read all the safety instructions and the prestart up section of this manual before operating the equipment.



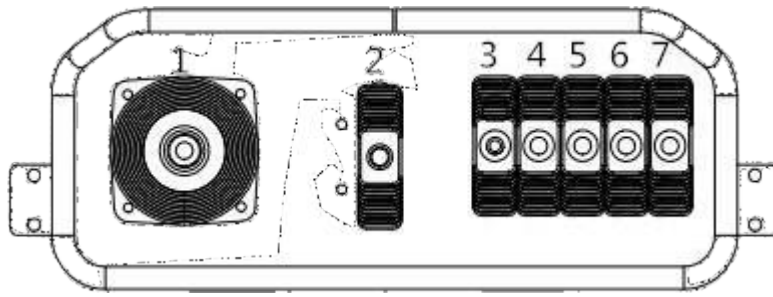

IMPORTANT: Ensure the auxiliary hydraulic lever is in center position before attempting to start engine. The most common cause of “hard to start / engine will not turn over fast enough / battery does not have enough power’ type starting problems is that the auxiliary lever has been left on or knocked into gear and the engine is trying to start under load. **Ensure auxiliary lever is in center position before starting engine.**



Drive Control Levers:



Lift/Tilt Control Lever (Lever 1)

- Forward  tilt attachment forward
- Back.  tilt attachment backward
- Left  raise the loading arm
- Right  lower the loading arm

Throttle Lever (Lever 2):

- Push forward to increase engine RPM, Pull backwards to reduce engine RPM

Auxiliary Hydraulics Lever (Lever 3/4);

The auxiliary hydraulic lever is to allow you to alter the direction of rotation of hydraulic driven attachments or stop them completely.

You could choose either Lever 3 or Lever 4 to operate if there is no motor or only one motor on the attachment.

If there are 2 motors on the attachment, operate Lever (3) and (4) together at the same time to alter the direction of attachments.

Driving speed Select Lever (Lever 5):

Push forward to select high speed. Push backwards to select low speed.

Drive control levers (Lever 6, 7):

1. To move forward, Push the drive control levers (6), (7) forward. To move rearward, pull the drive control levers (6), (7) rearward.
2. To go straight, move both (6) and (7) drive control levers equally.
3. To turn, decrease pressure on the drive control lever closest to the direction you want to turn. The farther you move the drive control levers in either direction, the faster the machine will move in that direction.
4. To slow or stop, move or release the drive control levers (6), (7) into neutral. (If released the control levers should automatically return to neutral).

Spin Turn

CAUTION: Make sure to use the machine handholds while doing a spin turn to maintain your balance.

Move the control levers in opposite directions to spin the machine on its axis.

To spin left, move the right control lever forward while pulling the left control lever backwards.

To spin turn to the right, push the left control lever forward while pulling the right control lever backward.

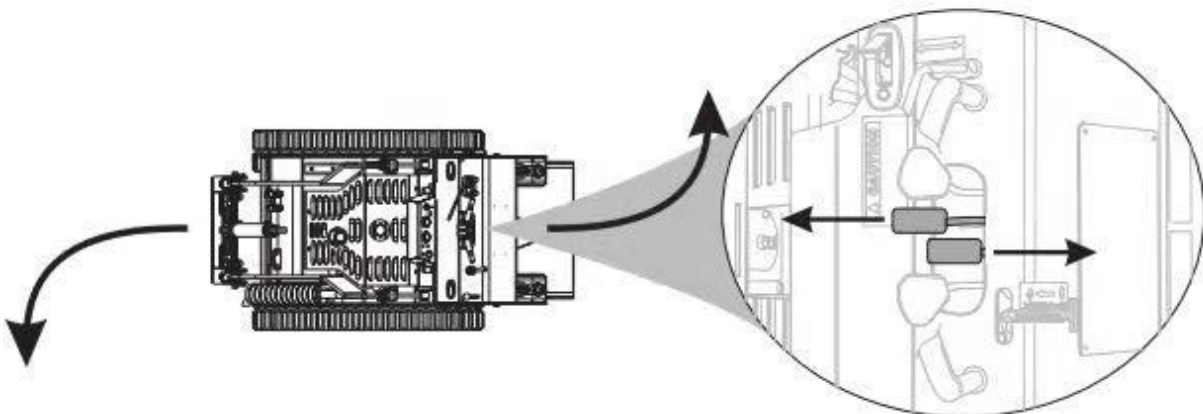

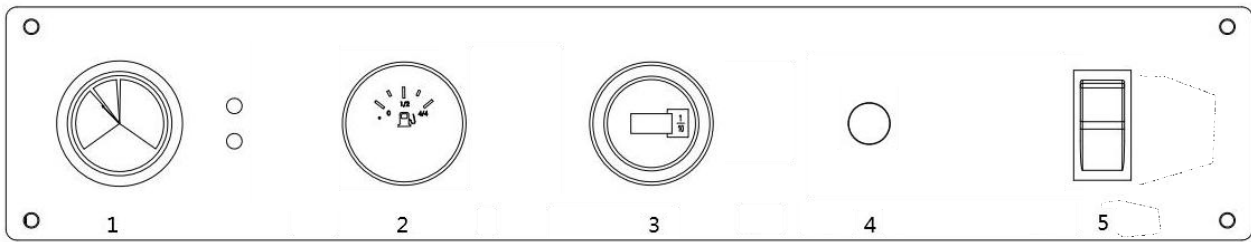

Instrumental Panel

1. FUEL PRESSURE GAUGE	2. FUEL GAUGE
3. VOLTAGE METER	4. ENGINE OIL PRESSURE LIGHT
5. WORKING LIGHT SWITCH	

1. FUEL PRESSURE GAUGE: When the pointer is in green range, it is normal. When the pointer is in red range, stop the loader and replace oil return filter.
2. FUEL GAUGE: It shows the fuel level. When it is in red range, it shows fuel insufficient. Then stop the engine and refuel.
3. VOLTAGE METER: It shows the battery voltage. When the display quantity is less than 11V, the battery needs to be charged or replaced
4. ENGINE OIL PRESSURE LIGHT: When engine oil pressure is too low, the light will be on. Stop the loader and shut off the engine, find out the trouble. Do not operate the machine until the trouble is cleared.
5. WORKING LIGHT SWITCH: Press the switch and light will turn on.

Starting and stopping the Engine

Starting

1. Stand on the platform.
2. Move the auxiliary hydraulics lever to neutral.

ATTENTION: Ensure auxiliary hydraulic lever is in neutral position before starting engine. Aside from starting difficulties the attachment may move during starting.

Stopping

1. Move the throttle lever to "slow".
2. Lower loader arms to the ground.
3. Turn the ignition key to off.

Note: If the engine has been working hard or is hot, let it idle for a minute before turning the ignition key "OFF". This helps cool the engine before it is stopped.

In an emergency, turning the ignition key to "OFF" will stop the engine.

Attachments

Connecting

IMPORTANT: Use only manufacturer approved attachments. Attachments could change stability and operating characteristics of the machine. The warranty of the machine may be voided if used with unapproved attachments.

IMPORTANT: Before connecting any attachments to the machines, make sure mount plates are free of any dirt and debris.

1. Move speed control lever to slow (turtle) position.
2. Slowly push the attachment tilt lever forward to tilt the attachment mount plate forward.
3. Position mount plate into the upper lip of the attachment's receiver plate.
4. Raise the loader arms while tilting back the mount plate at the same time.

IMPORTANT: The attachment should be raised enough to clear the ground and the mount plate tilted all the way back.

5. Turn the ignition key to "OFF" to stop the engine.
6. Engage the attachment lock pins.

Note: Lock pins are located on the operator side of the mount plate and should be turned toward the inside to engage.

Note: Proceed to next step if auxiliary hydraulics are required with attachment.

IMPORTANT: Make sure all foreign matter is cleaned from hydraulic connections before making connections.

7. Move the auxiliary hydraulics lever to the forward, backward, and back to neutral position to relieve hydraulic pressure at the hydraulic couplers.
8. Remove protective covers from the hydraulic couplers on machine. Connect covers together to prevent contamination during operation.
9. Confirm that connection is secure by pulling on the hoses.

Disconnecting

1. Lower attachment onto a firm, level surface.
2. Shut off the machine engine
3. Move the auxiliary hydraulics lever forward, backward and back to normal position to relieve hydraulic pressure at the hydraulic couplers.
4. Slide collar back on the hydraulic coupler and disconnect attachment couplers from machine couplers. (Note: if this is difficult return to step 3 and repeat.)

IMPORTANT: Connect attachment hoses together to prevent contamination during storage.

5. Install protective covers onto machine's hydraulic couplers.
6. Disengage the attachment lock pins by turning them to the outside.
7. Start engine, tilt the mount plate forward and back machine away from attachment.

After Each Use



WARNING

Move all controls to neutral position when stopped.

Load and unload trailer on level ground.

Transporting and securing

IMPORTANT: When transporting machine on a trailer, always use the following procedure.

1. Lower the loader arms.
2. Turn the ignition key to "OFF" to stop the engine.
3. Secure the machine to the trailer with chains or straps using the rear platform support openings to secure of machine and loader arms/mount plate to secure front of machine.

CAUTION! If children or bystanders attempt to operate the machine, someone could be injured. To avoid attempted use by children or bystanders while machine is unattended, remove the key from the ignition, even if just for a few minutes.

Moving a Non-functioning machine

IMPORTANT: Never tow the machine because hydraulic damage may occur.

1. Turn the ignition key to "OFF" to stop the engine.
2. Lift the entire machine off the ground and move the machine.

Maintenance



WARNING

- Keep your machine in good repair.
- Keep all cutting tools sharp and clean. Properly maintained cutting tools with sharp cutting edges are less likely to bind and are easier to control.
- Keep handles dry, clean, and free from oil and grease.

Maintain the machine by adopting a program of conscientious repair and maintenance in accordance with the following recommended procedures. It is recommended that the general condition of any tool be examined before it is used.

Maintenance Interval	Maintenance Point
Every 25 hours	<ol style="list-style-type: none"> 1. Check hydraulic oil level and check for external leaks; 2. Service pre-cleaner element (1); 3. Check bushes & replace if required; 4. Check engine oil level.
Every 50 hours	<ol style="list-style-type: none"> 1. Check hydraulic oil level and check for external leaks; 2. Check hydraulic hoses and tighten if required; 3. Replace air cleaner & clean pre-cleaner); 4. Check of fuel pipes and clamp bands; 5. Check engine oil level
Every 100 hours	<ol style="list-style-type: none"> 1. Change engine oil & filter; 2. Test all functions in operation; 3. Check – clean spark plug (s); 4. Replace fuel filter; 5. Replace air cleaner element); 6. Remove cooling shrouds and clean cooling area's; 7. Check oil cooler fins, clean as necessary.
Every 500 hours	<ol style="list-style-type: none"> 1. Change hydraulic fluid; 2. Change hydraulic filter; 3. Remove sediment in fuel tank.

It is recommended that some parts be always kept on hand for maintenance purposes.

Bushes:

1. The equipment has 10 Duralon bushes and chrome pins. These are located on either end of your hydraulic cylinders and on all pivot points of the lift arms.
2. These bushes are a wear part and require regular inspection. It is essential that these bushes be replaced on the first sign of wear, otherwise costly damage will occur.
3. You should ensure that spare bushes are on hand at all times.

Engine Oil

Changing/ Draining oil

1. Start the engine and let it run for 5 minutes. This warms the oil, so it drains better.
2. Park the machine so the drain side is slightly lower than the opposite side to assure that the oil drains completely. Then lower the loader arms, chock the wheels and turn the ignition key to "OFF" to stop the engine. Remove the key.
3. Place the end of the hose in a pan. Remove bung by turning counterclockwise while holding the nut. Allow to drain.
4. When oil has drained completely, replace the bung.

Note: Dispose of used oil in accordance with local authority regulations.

5. Slowly pour approximately 80% of the specified amount of oil into the filter tube. Now check the oil level. Slowly add additional oil to bring to "FULL" mark on dipstick.

Changing Oil Filter

Change oil filter every 100 hours.

Fuel Filter

Replace the fuel filter after every 100 operating hours or yearly, whichever occurs first. Replacing the Fuel Filter

1. Never re-install a dirty filter.
2. Lower the loader arms and turn the ignition key to "OFF" to stop the engine. Remove the key.
3. Clamp fuel line between fuel tank and fuel filter to block fuel flow.
4. Squeeze the ends of the hose clamps together and slide them away from the filter.
5. Place a drain pan under the fuel lines to catch any leaks, then remove the filter from the fuel lines.
6. Install a new filter and move the hose clamps close to the filter.
7. Remove clamp blocking fuel flow.

Fuel Tank

Draining the fuel tank.

IMPORTANT:

Drain the diesel oil from the fuel tank when the engine is cold.

Do this outdoors in an open area. Wipe up any oil that spills.

Never drain the oil near an open flame or where a spark may ignite fumes.

Never smoke while handling fuel.

1. Park the machine on a level surface, to assure fuel tank drains completely. Then lower the loader arms and turn the ignition key to "OFF" to stop the engine. Remove the key.
2. Loosen the hose clamp at the fuel filter and slide it up the fuel line away from the fuel filter.
3. Pull the fuel line off the fuel filter, open the fuel valve, and allow gasoline to drain into a gas can or drain pan.
4. Remove tank from the machine by undoing nut at clamp at top of tank. Remove tank, drain completely and flush by tipping tank upside down.
5. Reverse procedure to replace clean tank.
6. Note: Now is the best time to install a new fuel filter because the fuel tank is empty.
7. Install the fuel line onto the fuel filter. Slide the hose clamp close to the fuel filter to secure the fuel line.

Hydraulic system

Replacing the Hydraulic filter

Change the hydraulic filter: After every 500 operating hours.

- Never replace the hydraulic oil filter when the oil is still hot.
- Used oil filters should be collected in accordance with local regulations.

Replace the hydraulic oil filter in the following steps:

1. Raise the loader arms and install the safety support, stop the engine, and remove the key.
2. Open the oil tank flange to release the remaining pressure inside the tank
3. Screw off the oil filter.
4. Installing a new filter and tighten it clockwise until it is fastened well.
5. Close the oil tank flange.

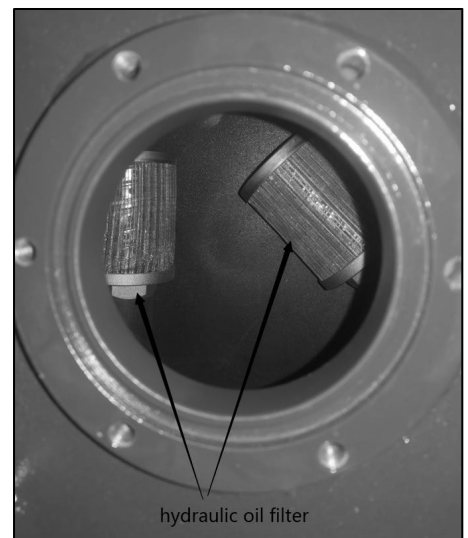

Changing the Hydraulic Fluid

Change the hydraulic fluid: After every 500 operating hours

1. Position the machine on a level surface, lower the loader arms and turn the ignition key to "OFF" to stop the engine.
2. Remove the key.

IMPORTANT: Do not substitute automotive oil filter or severe hydraulic damage may result.

3. Place large drain pan under the machine that can hold at least 70 liters.
4. Remove the drain plug from the bottom of the hydraulic tank and allow the fluid to completely drain out.
5. Remove the tank top and wipe out the inside of the tank. Note if any foreign objects are there. If anything unusual is found, consult your service center or a hydraulic expert.
6. Install the drain plug.
7. Fill the hydraulic tank with approximately 33 liters of H68 Hydraulic oil.
8. Dispose of used oil in accordance with local authority regulations.

Check hydraulic lines

After every 100 operating hours, check hydraulic lines and hoses for leaks, loose fittings, kinked lines, loose mounting supports, wear, weather and chemical deterioration.

Replace all moving hydraulic hoses every 1500 hours or two years, whichever comes first.

Make necessary repairs before operating.

WARNING!

Hydraulic pressure escaping under pressure can penetrate the skin and cause injury.

Keep hands and body away from pin hole leaks or nozzles that eject high pressure hydraulic fluid. A small leak can be dangerous. To find hydraulic leaks, use cardboard or paper.

Battery

Always keep the battery clean and fully charged. Use a paper towel to clean the battery case.

If the battery terminals are corroded, clean them with a solution of four parts water and one part baking soda. Apply a light coating of grease to the battery terminals to reduce corrosion.

Voltage: 12V, 380 Cold Cranking Amps.

If battery becomes flat or machine is not used for a long period, charge the battery using an external battery charger.

Do not rely on the engines charging system to recharge a battery. It is only meant to maintain charge in a good battery.

Cleaning and long-term storage

1. Lower the loader arms and turn the ignition key to “OFF” to stop the engine. Remove the key.
2. Remove dirt and grime from the external parts of the entire machine, especially the engine. Clean dirt and chaff from the outside of the engines cylinder head fins and blower housing.

IMPORTANT: You can wash the machine with mild detergent and water. Do not pressure wash the machine. Avoid excess use of water, especially near the control panel, engine, hydraulic pumps and motors.

3. Service the air cleaner; refer to section on Air Cleaner.
4. Change the crankcase oil.
5. Charge the Battery; refer to section on Batteries.
6. For long-term storage (more than 90days) add stabilizer/conditioner additive to fuel tank.
 - a. Run engine to distribute conditioned fuel through the fuel system (5 minutes).
 - b. Stop engine, allow to cool and drain the fuel tank; refer to section on Fuel Tank.
 - c. Restart engine and run it until it stops. Repeat, on “CHOKE” until engine will not restart.
 - d. Dispose of fuel properly.
7. Check and tighten all bolts, nuts, and screws. Repair or replace any part that is damaged or defective.
8. Store the machine in a clean, dry garage or storage area.
9. Remove the key from the ignition switch and keep it in a memorable place.
10. Cover the machine to protect it and keep it clean.

Maintenance Log

Sign and Date	25 hours
	Check hydraulic oil level and check for external leaks;
	Service pre-cleaner element (1);
	Check bushes & replace if required;
	Check engine oil level

Sign and Date	50 hours
	Check hydraulic oil level and check for external leaks;
	Check hydraulic hoses and tighten if required;
	Replace air cleaner & clean pre-cleaner);
	Check of fuel pipes and clamp bands;
	Check engine oil level

Sign and Date	75 hours
	Check hydraulic oil level and check for external leaks;
	Service pre-cleaner element (1);
	Check bushes & replace if required;
	Check engine oil level

Sign and Date	100 hours
	Change engine oil & filter;
	Test all functions in operation;
	Check – clean spark plug (s);
	Replace fuel filter;
	Replace air cleaner element);
	Remove cooling shrouds and clean cooling area's;
	Check oil cooler fins, clean as necessary.

Sign and Date	125 hours
	Check hydraulic oil level and check for external leaks;
	Service pre-cleaner element (1);
	Check bushes & replace if required;
	Check engine oil level

Maintenance Log

Sign and Date	150 hours
	Check hydraulic oil level and check for external leaks;
	Check hydraulic hoses and tighten if required;
	Replace air cleaner & clean pre-cleaner);
	Check of fuel pipes and clamp bands;
	Check engine oil level

Sign and Date	175 hours
	Check hydraulic oil level and check for external leaks;
	Service pre-cleaner element (1);
	Check bushes & replace if required;
	Check engine oil level

Sign and Date	200 hours
	Change engine oil & filter;
	Test all functions in operation;
	Check – clean spark plug (s);
	Replace fuel filter;
	Replace air cleaner element);
	Remove cooling shrouds and clean cooling area's;
	Check oil cooler fins, clean as necessary.

Sign and Date	225 hours
	Check hydraulic oil level and check for external leaks;
	Service pre-cleaner element (1);
	Check bushes & replace if required;
	Check engine oil level

Sign and Date	250 hours
	Check hydraulic oil level and check for external leaks;
	Check hydraulic hoses and tighten if required;
	Replace air cleaner & clean pre-cleaner);
	Check of fuel pipes and clamp bands;
	Check engine oil level

Maintenance Log

Sign and Date	275 hours
	Check hydraulic oil level and check for external leaks;
	Service pre-cleaner element (1);
	Check bushes & replace if required;
	Check engine oil level

Sign and Date	300 hours
	Change engine oil & filter;
	Test all functions in operation;
	Check – clean spark plug (s);
	Replace fuel filter;
	Replace air cleaner element);
	Remove cooling shrouds and clean cooling area's;
	Check oil cooler fins, clean as necessary.

Sign and Date	325 hours
	Check hydraulic oil level and check for external leaks;
	Service pre-cleaner element (1);
	Check bushes & replace if required;
	Check engine oil level

Sign and Date	350 hours
	Check hydraulic oil level and check for external leaks;
	Check hydraulic hoses and tighten if required;
	Replace air cleaner & clean pre-cleaner);
	Check of fuel pipes and clamp bands;
	Check engine oil level

Sign and Date	375 hours
	Check hydraulic oil level and check for external leaks;
	Service pre-cleaner element (1);
	Check bushes & replace if required;
	Check engine oil level

Maintenance Log

Sign and Date	400 hours
	Change engine oil & filter;
	Test all functions in operation;
	Check – clean spark plug (s);
	Replace fuel filter;
	Replace air cleaner element);
	Remove cooling shrouds and clean cooling area's;
	Check oil cooler fins, clean as necessary.
Sign and Date	425 hours
	Check hydraulic oil level and check for external leaks;
	Service pre-cleaner element (1);
	Check bushes & replace if required;
	Check engine oil level
Sign and Date	450 hours
	Check hydraulic oil level and check for external leaks;
	Check hydraulic hoses and tighten if required;
	Replace air cleaner & clean pre-cleaner);
	Check of fuel pipes and clamp bands;
	Check engine oil level
Sign and Date	475 hours
	Check hydraulic oil level and check for external leaks;
	Service pre-cleaner element (1);
	Check bushes & replace if required;
	Check engine oil level
Sign and Date	500 hours
	Change engine oil & filter;
	Test all functions in operation;
	Check – clean spark plug (s);
	Replace fuel filter;
	Replace air cleaner element);
	Remove cooling shrouds and clean cooling area's;
	Check oil cooler fins, clean as necessary.
	Change hydraulic fluid;
	Change hydraulic filter;
	Remove sediment in fuel tank.

Troubleshooting

Use the table below to troubleshoot problems before contacting service personnel, if the problem continues after troubleshooting, call your local dealer for assistance.

Failure	Possible Cause	Corrective Action
Starter does not crank	1. Battery is dead.	1. Change the battery.
	2. Electrical connections are corroded or loose.	2. Check electrical connections for good contact.
	3. Relay switch is defective.	3. Contact authorized service dealer.
Engine will not start, starts hard, or fails to keep running	1. Auxiliary hydraulics lever is not in neutral position.	1. Move the lever to neutral position.
	2. Fuel tank is empty.	2. Fill fuel tank with gasoline.
	3. Air cleaner is dirty.	3. Clean or replace air cleaner element.
	4. Dirt in fuel filter.	4. Replace fuel filter.
	5. Dirt, water, or stale fuel is in the fuel system.	5. Contact Authorized service dealer.
Engine loses power	1. Engine load is excessive.	1. Reduce ground speed.
	2. Air cleaner is dirty.	2. Clean air cleaner element.
	3. Cooling fins and air passages under engine blower housing are plugged.	3. Remove obstruction from cooling fins and air passages.
	4. Dirt in fuel filter.	4. Replace fuel filter.
	5. Dirt, water, or stale fuel is in fuel system.	5. Contact authorized service Dealer.
	6. Breather on fuel tank is closed.	6. Open breather.
Engine overheats	1. Engine load is excessive.	1. Reduce ground speed.
	2. Cooling fins and air passages under engine blower housing are plugged.	2. Remove obstruction form cooling fins and air passages.
	3. Water level is low (diesel only)	3. Top up water.
Abnormal vibration	Engine mounting bolts are loose.	Tighten engine mounting bolts.
Machine does not drive	1. Hydro fluid level low.	1. Add hydro fluid to reservoir.
	2. Traction pump drive coupler is loose or broken.	2. Contact Service Dealer.
	3. Pump and /or wheel motor is defective or damaged.	3. Contact Service Dealer.
	4. Control valve is defective or damaged.	4. Contact Service Dealer.
	5. Relief valve is defective or damaged.	5. Contact Service Dealer.



For spare parts, support or warranties please complete the form at www.aftersalescare.com.au