



King 2.3 Digger

Manual for Operation

Contents

Safety Warning Signs	5
Signal Words	6
Foreword	6
Serial number	7
Machine Description	8
Designated Operations.....	8
Product Features	8
Operate as per the following instructions:	8
Notes about Reading of This Manual	8
Safety	9
General Precaution.....	9
Abiding by All Safety Regulations	9
Upon detection of machine abnormality.....	9
Operating Temperature Range.....	9
Wearing Appropriate Clothing and Protective Appliances	10
Setup of Signaler and Flagman	11
Precaution for Standing up from or Leaving Driver.....	11
Toxic Exhaust Gas from Engine.....	13
Guard against Crushing and Cuts.....	14
Precaution during Preparations.....	14
Understanding of working zone	14
Daily Checking and Maintenance	15
Precaution within Cab (If installed)	15
Safety Measures at Start	16
For Cold Weather	17
Operation Precaution.....	17
Checking of Visibility before Operations of Machine	17

Checking for Safe and Reliable Working Zone before Operations.....	18
Checking of Chassis (Tracks) before Traveling.....	18
Precaution for Traveling on Slopes.....	19
Precaution for Parking.....	25
Safe Lifting of Machine.....	26
Safe Transport of Machine.....	27
Precaution for Maintenances	27
No Disassembling of Track Tensioner.....	32
Disconnection of Battery Cables.....	32
Jumper Start with Battery Charging Cable.....	33
Asking Your Service Dealer for Welding Repair	34
Vibration Applied on Operator	34
Checking after Maintenance.....	34
Safety Signs (Markings)	35
Safety Sign (Markings).....	36
Warning Signs	37
Controls.....	40
Maintenance	72
Maintenance List	83
Walk-Around Checking	84
Daily routine checking (Every 10h).....	85
Every 50h.....	91
Every 100h.....	93
After first 250h (For new machine only).....	94
Every 250-hour.....	94
Every 500-hour.....	97
Every 1000h.....	97
Every 1500-hour.....	99
Every 2000h.....	99

Maintenances during Long-Time Parking	106
Troubleshooting	108
Symptoms other than Malfunctions.....	108
Engine Overheating	108
No Battery Power	109
Burnout of Fuse	111
Restart after Refueling	112
Flashing of Warning Lamps	113
Other Symptoms.....	114
Towing.....	116
Damage of Cab or Shelter.....	116
Support:.....	117

Safety Warning Signs

WARNING!



This sign denotes a safety warning.

Please read and understand this information to prevent personal injuries.

The machine owner or employer is responsible for instructing every operator to operate all equipment correctly and safely. All personnel operating this machine shall sufficiently understand the contents of this manual.

Before operating the machine, all operation personnel must receive the guidance on related functions of excavator.

Before operating this machine in a working site, learn and practice how to use the machine controls correctly in a safe place.

Improper methods of operation, checking, and maintenances of machine could result in injuries or deaths. Before any operation, checking, or maintenance of machine, please read and understand this manual.

Please always carry this manual with you. It's preferable to preserve this manual on the machine. If this manual is lost or damaged, please immediately order a new manual from a dealer. At the transfer of this machine, please ensure to hand this manual over to the new owner.

The machine supplied by us conforms to the local standards and specifications of Australia. If your machine is purchased from other country or from an individual or company of other country, this machine is probably not installed with the safety devices or safety standards required for the operations of this machine in your country. If you have any doubt on the compliance of your machine with the relevant standards and regulations in your country, please contact your dealer.

Signal Words

The safety information in this manual and machine identifications is indicated by words “Danger”, “Warning”, and “Notice”. The meanings of these signal words are as below:

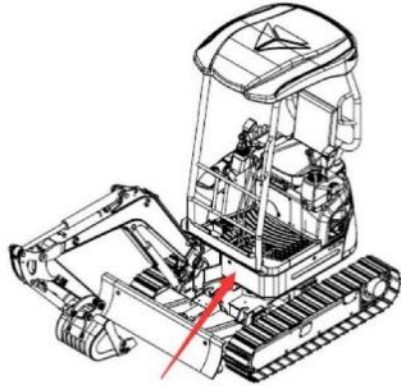

Danger

“Danger” denotes high dangerous level, for which negligence will result in death or serious injury.

Warning

“Warning” denotes medium danger level, for which the negligence may result in death or serious injury.

Notice

“Notice” denotes low danger level, for which the negligence will result in minor or medium injuries.

Important: The word “Importance” is intended to alert the operation and maintenance personnel of the possible damages of machine and its components.

T warnings in this manual or on this machine can't cover all possible accidents. Therefore, during the operation of the machine, ensure to take caution and abide by all conventional safety measures to prevent harm to machine, operation personnel, or other personnel.

Foreword

This manual describes the operation, checking, and maintenances of this machine and the safety descriptions to be observed during operations.

Should you have any doubt, please contact your dealer.

Please be noted that the information contained in this manual and the parameters of this machine are subject to changes without further notice.

Serial number

Important: Do not disassemble the machine nameplate with serial number. Observe the serial numbers of machine and engine and record them in the blank area below.

Machine No.:

Engine No.:

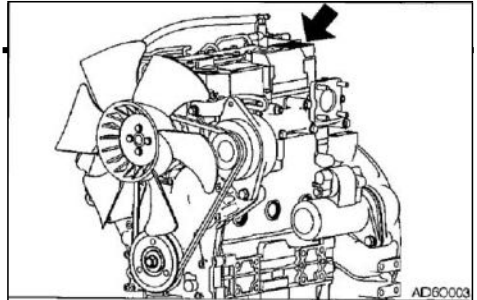

Machine Description

Front, Rear, Left, and Right

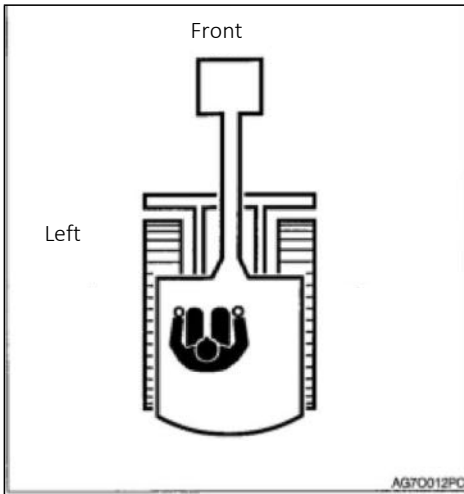

The front, rear, left, and right of the machine indicated in this manual are based on the status sitting in the driver seat, with the bulldozing blade visible in the front.

Designated Operations

This machine is mainly applied for following operations:

- Digging
- Ditching
- Side ditching
- Leveling
- Loading

Product Features

- “Flexible machine width structure”

track width

- Low engine noise and emission
- Run-in First 100h (Based on reading of hour meter) for new machine

Operate as per the following instructions:

Using a new machine without running-in will deteriorate acceleration performance and probably shorten the life of machine.

Sufficiently warm up the engine and hydraulic oil.

Avoid heavy-load and rapid operations.

Maintain the load at approximately 80% of maximum load capacity during operations.

Do not start, accelerate, steer, or stop suddenly, unless it's really necessary.

Notes about Reading of This Manual

Please be noted that the descriptions and graphics contained in this manual are general representations for your guidance.

Safety



General Precaution

You are liable for abiding by the safety laws and regulations of relevant departments and fulfilling the operations, checking, and maintenances of machine.

Please read and understand all safety information related to the prevention of accidents.

Please ensure to operate the machine only after you have understood how to operate, check, and maintain the machine correctly.

Abiding by All Safety Regulations

The machine must be operated, checked, and maintained by trained and qualified personnel.

During the operations, checking, and maintenance of machine, ensure to understand and abide by all rules, regulations, precaution, and safety measures.

Do not operate, check, or maintain the machine under the adverse influence of alcohol, drug, medicine, or fatigue.

Upon detection of machine abnormality

During the operation, checking, or maintenances of the machine, if any abnormality is detected (Such as noise, vibration, smell, abnormal instrument, smoking or oil leakage, error warning indication, and abnormal display of electric control panel), immediately notify a sales or service dealer and take appropriate measures.

Do not operate the machine before the abnormality is resolved.

Operating Temperature Range

To maintain performance and prevent the early wear of machine, please abide by the following operating conditions.

Do not operate the machine when the outside temperature is more than +45°C or less than -15°C

The operations under +45°C outside temperature may result in engine overheating and deteriorated engine performance. In addition, the hydraulic oil may become really hot which may cause harm the hydraulic devices.

Operations under -15°C outside temperature may harden the rubber parts (Such as gaskets) and

cause earlier wear or damage of machine.

To operate the machine under conditions outside the above-mentioned temperature range, please consult with your sales or service dealer.

Wearing Appropriate Clothing and Protective Appliances

Installation of Fire Extinguisher and First-Aid Kit

Do not wear loose clothing or items that may catch on any joystick or moving parts.

Do not wear oil or fuel contaminated clothing.

Wear safety shoes, safety helmet, safety goggles, filtration mask, thick gloves, earflaps, and other protective equipment. During the use of grinding miller, breaking hammer, or compressed air, please wear appropriate protective appliances, such as safety goggles and filtration mask, as the splashing of metal chippings or other objects can cause serious harm.

Please use the hearing protection devices during the operations of machine. Exposure to a high noise environment for a long time will result in harm or even complete loss of hearing.

Install the fire extinguisher and first-aid kit and learn how to use them. Please refer to the instructions on the fire extinguisher and first aid kit.

Compile an emergency contact list and know who to contact in an emergency in your area.

In Australia dial 000 for emergencies.

No Disassembling of Safety Devices

Always keep all safety devices in good working order.

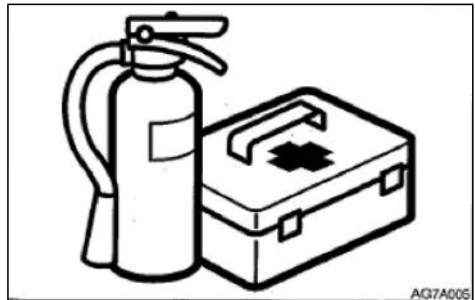

Setup of Signaler and Flagman

Learn how to use the gestures of specific operation needs and designate the person responsible for making gestures.

All personnel must completely understand all gestures.

The operator must respond to the gestures of the designated person only. However, the operator must abide by the stop gesture made by anyone in all cases.

The signaler must stand in a clearly visible place while making the gestures.

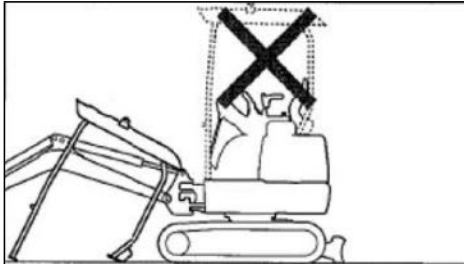

Precaution for Standing up from or Leaving Driver

Before standing up from the driver seat to open/close windows or disassemble/install the lower window, lower the working device onto the ground, lift up and lock the safety lock handle and stop the engine. When the safety lock handle is lowered down

(Unlocked), accidental movement of the joystick can result in sudden movement of machine and may cause serious injuries or deaths.

Know how to use safety lock handle, seat belt, and other safety devices and understand the correct operation methods.

Do not disassemble any safety device, unless for the purpose of checking and repair.

Please ensure that all guardrails, shelters, and doors are installed properly and securely. Before operating the machine, please repair or replace damaged parts.

Please be noted that, even if the safety lock handle is placed at locking position, the bulldozing blade, boom, and auxiliary hydraulic controls can't be locked. Do not touch controls accidentally.

While lifting up or lowering down the safety lock handle, take caution not to touch any joystick.

Before leaving the driver seat, lower the working device onto the ground, lift up the safety lock handle to locking position, and stop the engine. Meanwhile, ensure to withdraw the key, close the doors and hoods, and carry the key with you and then preserve it in a designated place.

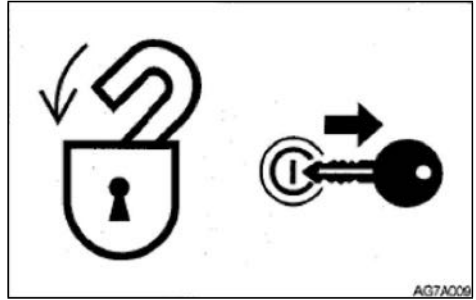

Guard against Fire and Explosion Dangers



fuel or lubricating oil.

Do not disassemble the fuel tank cap or refuel while the engine is running or is not cooled down. In addition, do not splash fuel to any machine hot surface or electronic system part. Immediately clean the overflowed fuel or lubricating oil thoroughly.

Check for leakage of fuel and lubricating oil. Please eliminate the leaks and clean the machine before operation.

Please move the flammables to a safe place before polishing or welding operations. Do not cut or weld any pipeline or pipe that may contain flammable liquid. Please clean thoroughly by non-flammable solvent before cutting or welding.

Keep fuel, lubricating oil, grease, and antifreeze away from flame. The fuel is especially flammable and dangerous. Handle these flammables away from ignited cigarettes, matches, lighters, and other flame or ignition source.

Do not smoke or use open fire while handling fuel or performing the operations of the fuel system.

Do not leave the operation site while filling

Remove all wastes and impurities from the machine. Ensure that there is no oil contaminated rags or other flammables on the machine.

Handle all solvents and dry chemicals (Foam fire extinguisher) as per the manufacturer's procedures indicated on the container. Operate in a well-ventilated place. Never use fuel for cleaning purpose.

Always use non-flammable solvent. Please ensure thorough ventilation during the handling of fuel and the cleaning of oil stain or paint. Preserve all flammable liquids and materials in a safe and well-ventilated place.

The short-circuit of the electrical system may result in fire. Check the wire connections daily for looseness and damage. Re-tighten loose connectors and cable clamps. Repair or replace damaged wires.

Fire accident caused by pipelines: Ensure that the clamps, protection devices, and cushion pads of hoses and pipes are securely fixed. If loose, the hoses and pipes will be damaged due to vibration or contact with other parts during operations. This may result in spraying of high-pressure oil to cause fire accident or harm.

Toxic Exhaust Gas from Engine

Do not operate the engine in an enclosed place with poor ventilation. If natural ventilation is not possible, install ventilation fan, fan, extended exhaust pipe, or other ventilation device.



Handling of Asbestos Powders

The inhalation of asbestos powders may cause lung cancer. While handling materials that may contain asbestos, take the following safety measures:

- Do not sweep with compressed air.
- Avoid polishing or grinding asbestos-

contained parts.

During cleaning, use a vacuum device installed with high-efficiency particulate air filter (HEPA). If there is no other method for control of powders, please wear the specified respirator. During indoor operations, please install a ventilation system with polymer filter.

Guard against Crushing and Cuts

During operations, non-authorized personnel are prohibited to access the working zone.

Please strictly abide by the rules and environmental standards applicable for this working zone.

Never place your hand, foot, or other body parts between the superstructure and chassis or tracks, between machine body and working device, or between cylinder and motion parts. During movement of machine, these clearances will change and may cause serious injuries or deaths.



Precaution during Preparations

Understanding of working zone

Before starting operations, understand the situation of working zone to ensure safety.

Check the terrain and ground situation of working zone. For indoor operations, check the building structure and when necessary, take safety measures.

Ensure to keep away from dangers and obstacles such as water ditch, underground pipelines, trees, cliffs, overhead cables, and roads with falling stone or landslide danger.

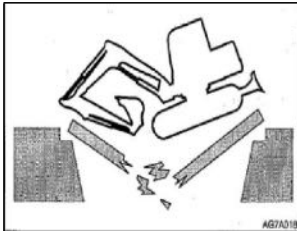
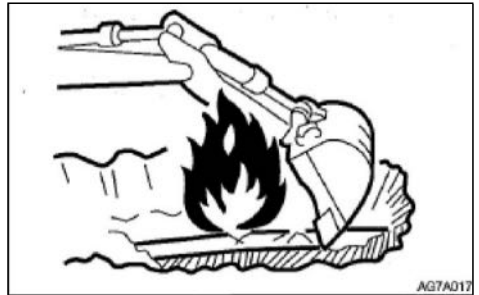

Check the positions of underground gas pipelines, water pipelines, and electric cables together with administrator. If necessary, discuss with administrator to determine the detailed safety measures to be taken to ensure safety.

During operations on road, ensure to take the safety of pedestrians and vehicles into consideration. Use a signaler and/or signals. Isolate the working zone against access to non-

authorized personnel.

Before operations in water or driving through shallow rivers, check the water depth, ground firmness, and flow rate in advance. Understand more operation description information with reference to the “Precaution during Operations” Checking of Bridge Strength

Please check the permissible load before driving on bridges or structures. If the strength is insufficient, reinforce the bridges or structures.

Always Keeping Clean Machine

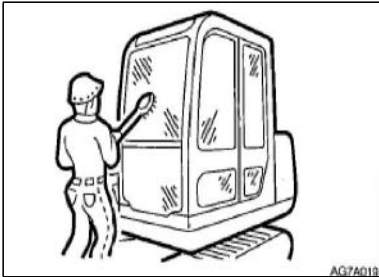

Wipe away lubricating oil, grease, mud, snow, and ice, in order to prevent accident due to slip. Eliminate all loose objects and unnecessary devices in the machine.

Remove dusts, lubricating oil, and grease from engine portion to prevent fire accident.

Clean the area around operator's seat and remove all unnecessary objects from the machine.

Daily Checking and Maintenance

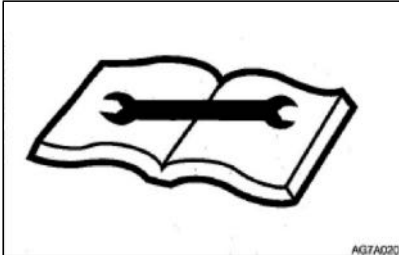

Before operations, fulfill the designated checking and when necessary, repair immediately. In event of operation failure due to malfunction or engine malfunction, immediately stop the engine as per stop procedure and park the machine securely, till the malfunction is repaired.

Precaution within Cab (If installed)

Before entering the cab, remove mud and oil/grease from your shoes. Operating the machine pedals with soiled shoe bottoms may result in accidents due to slips.

Do not place any part or tool around the driver seat.

Do not place any plastic bottles in the cab or install any suckers on window glasses. The plastic bottle or suckers can play a lens role and increase the chance of fires.

Do not use a mobile phone during traveling or operations.

Do not bring any inflammable or explosive into cab.

Do not leave a lighter in the cab. The lighter may explode due to the rise of room temperature.

Safety Measures at Start

Support your body weight by three-point safety posture while getting on/off the machine.



Do not jump on or off the machine. Do not attempt to get on or off a moving machine.

Before getting on or off the cab, firstly open the door completely to locking position and check and ensure that the door can't move further (For machine with cab).

Face towards the machine, get on/off the footplates, and grab the handrail to support your weight by three-point safety posture (Hands and feet). Do not use safety lock handle or any joystick as handrail.

Start the engine only after the safe start is confirmed by checking the following items.



Adjust the seat till it's securely locked.

Fasten the seat belt.

Check whether the parking device is actuated and all joysticks and pedals are in neutral.

Check whether the safety lock handle is at locking position.

Ensure there is no person near the machine.

Start and operate the machine only in driver seat.

Do not attempt to start the engine by short circuiting the terminals

Before starting machine, keep all **non-authorized personnel away from this zone**

Walk around the machine and alert the repair personnel and the personnel walking around the machine. Start the engine only after it's confirmed that there is no person around the machine

Check for warning sign "No Operation" or similar sign affixed on cab door, control, or starter switch. If present, do not start engine or touch any joystick.

After the start of engine, fulfill following operations and checking in a place without personnel or obstacle. Upon detection of any malfunction, stop the engine as per the procedure and report malfunction.

Sound the horn to alert the personnel around machine.

Sit in the driver seat and start the engine.

Warm up the engine and hydraulic oil.

Check all instruments and warning devices for normal functioning.

Check for presence of noise.

Test the engine speed control.

Operate all control devices to ensure normal functioning.

Start by Jumper Cable



Start by jumper cable only as per the recommended method. The improper use of jumper cable may result in battery explosion or unexpected machine motions.

Please refer to “In event of no battery power” to understand more operation description information.

For Cold Weather



Take caution that the frozen ground, footplates, and handrails are slippery. In cold weather, do not touch any metal part of machine by bare hands. Your skin may be frozen on metal parts which may cause serious injuries.

Do not use diethyl ether or starting fluid on the engine. The starting fluid can cause explosion and serious injuries or deaths.

Warm up the engine and hydraulic oil. Operating joysticks without warm-up will result in slow or inappropriate reaction or movement of machine which could lead to accidents.

Operation Precaution

Operating Machine with Maximum Track Width

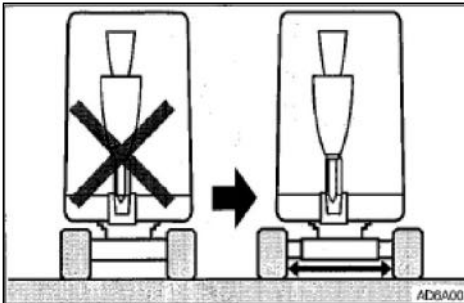

Always operate the machine with extended track width of 1,240mm, in order to improve the machine stability to the maximum extent.

Operating the machine with narrow track width (990mm) may result in rollover of machine due to poor stability.

If it's necessary to operate the machine with narrow track width (990mm), retract the bucket working device and lower the boom to reduce the gravity center and face the machine towards front before traveling.

Checking of Visibility before Operations of Machine

During operations in a dark place, turn on the working lamp and headlamp of machine and when

necessary, install additional lighting devices. In event of poor visibility due to severe weather (Such as fog, snow, rain, and haze), stop the operations of machine till the visibility turns good.

Clean the windows, mirrors, lamps, and camera to keep good visibility. Adjust the mirrors and camera to optimal positions to ensure that the driver sitting in the driver seat can see the rear view (Blind spot).

The non-authorized modification or the installation of non-approved attachments may impair the visibility of the operator.

No Riding on Machine



All personnel are prohibited to sit on any part of machine at any time during traveling or operations of machine.

Checking for Safe and Reliable Working Zone before Operations

Verify the performance limits of machine.

Set up a signaler at the road shoulders, narrow places, or vision-obstructed places.

Do not allow any person to access the turning radius or path of machine.

Sound the horn to indicate your movement intention.

There are blind zones behind the machine. Before driving backward, check the safety in the area behind machine and ensure there is no person behind the machine.

Checking of Chassis (Tracks) before Traveling

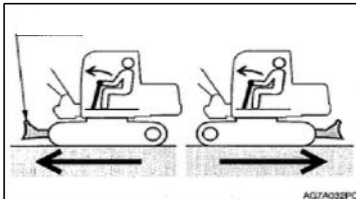

Bulldozing blade

Before operating the traveling joystick/pedal, ensure that the bulldozing blade is in front of the driver seat. Please bear in mind that the operation direction of the traveling joystick/pedal with bulldozing blade behind the driver seat is reverse to that with bulldozing blade in front of driver seat.

Safe Traveling

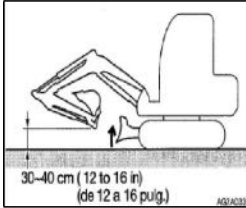

The bulldozing blade shall be lifted during traveling. Retract the bucket working device as shown in above diagram and lift the bucket by 30~40cm off the ground.

Do not slew during the traveling. If it's necessary to operate the bucket working device during traveling, operate at sufficiently low speed to ensure complete control at all times.

When the machine is traveling in 2nd gear (High speed) and a load higher than set value is applied, the machine will automatically slow down to 1st gear (Low speed). If the load is reduced, the machine will accelerate and return to 2nd \ gear (High speed).

Please be noted that the traveling speed varies depending on the load condition (For machine with automatic traveling gearshift reducer system).

Do not drive the machine on a slope steep enough to cause instability of machine. Please be noted that, in the actual applications, the performances of machine on a slope will be deteriorated due to severe working conditions.

Downhill

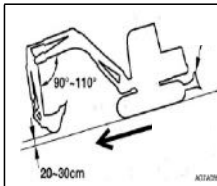

Avoid driving over obstacles whenever possible. If it's necessary to drive over obstacles, keep the bucket operating device near the ground and travel at low speed. Do not drive over any obstacle that will incline the machine by 10° or larger.

On rugged roads, drive the machine at low speed and avoid the sudden startup, stop, and direction change. Otherwise, the working device may come into contact with the ground to cause unbalance and damage of machine or destruct the structure in surrounding area.

Precaution for Traveling on Slopes

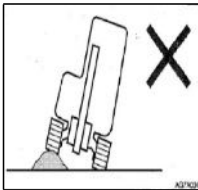

While traveling on slopes, take caution to prevent the rollover and gliding of machine. Keep the driver seat facing towards the upslope direction while climbing up a slope. Keep the driver seat facing towards the downslope direction during downslope traveling. In both cases, pay special attention to the ground ahead of the machine during traveling. While traveling on a slope, lower the bucket to 20~30cm off the ground. While climbing up a steep slope, extend the bucket working device to the front position. In event of an emergency, lower the bucket onto the

ground and stop the engine of machine.

While traveling on a slope, drive slowly in 1st gear (Low speed). Reduce the engine speed during downslope traveling. Do not reverse the machine down a slope.

Special Caution for Operations of Machine on Ice/Snow

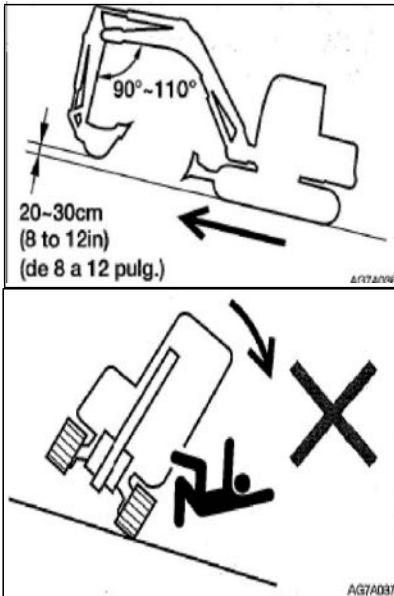

While traveling on snowy or icy roads, drive at low speed and avoid the sudden startup, stop, and direction change.

In snowy regions, the road curbs and the roadside objects are buried in the snow to become invisible. In addition, there is a danger of machine rollover or collision with covered objects. Therefore, always operate with caution.

There is a danger of rollover or snow entrapment while driving the machine into thick snow. Drive with caution and do not drive over road curbs or entrap in the snow. For frozen soil surface, the ground becomes soft when the temperature rises, which may result in rollover of machine and entrapment of operator in the machine.

While parking the machine on an unstable ground, lower the bulldozing blade.

Special Caution for Operations of Machine on Ice/Snow

While traveling on snowy or icy roads, drive at low speed and avoid the sudden startup, stop, and direction change.

In snowy regions, the road curbs and the roadside objects are buried in the snow to become invisible. In addition, there is a danger of machine rollover or collision with covered objects. Therefore, always operate with caution.

There is a danger of rollover or snow entrapment while driving the machine into thick snow. Drive with caution and do not drive over road curbs or entrap in the snow. For frozen soil surface, the ground becomes soft when the temperature rises, which may result in rollover of machine and entrapment of operator in the machine.

While parking the machine on an unstable ground, lower the bulldozing blade.

Keeping a Safe Distance from Overhead High-Voltage Cables

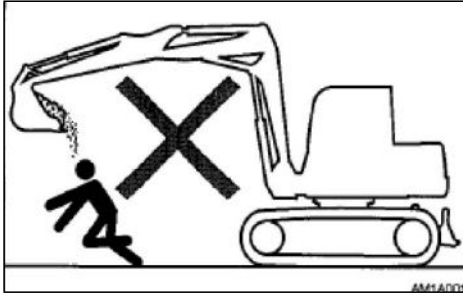

No Movement of Bucket over Personnel

Moving the bucket over personnel has a danger of splashing the loaded material or the sudden falling of bucket.

Guarantee of Driver's Safety during Loading

Do not load before the driver reaches a safe place.

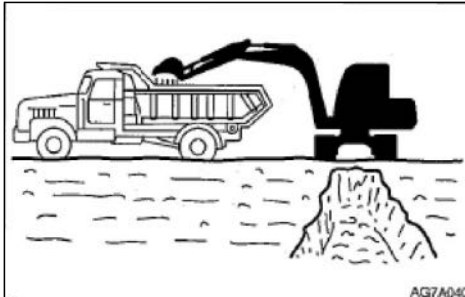

Do not swing or position bucket above personnel or cab. Load from the back door of trucks.

Never close any part or loaded material of machine to high-voltage cables, unless all safety measures specified by local and national authorities are already taken. There is a danger of electric shock and death when any person approaches to the machine that is discharging electric spark or is near or in contact with power supply.

Always keep a safe spacing between machine and high-voltage cables.

Before starting operations, please verify the relevant operation safety procedures with local power grid.

Consider all electric cables as high-voltage cables. Even if it's known or believed that the power supply is cut off or the cable is clearly

grounded, consider such cables also as live cables.

If the machine is too close to high voltage cables, set up a signaler to sound warnings. Keep all personnel within operation zone away from machine and loaded material.

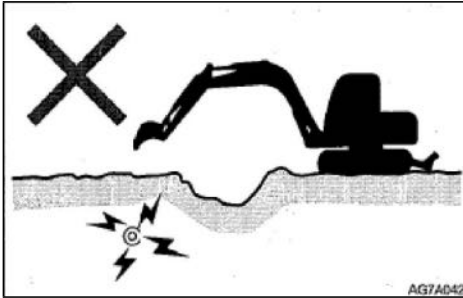

Pay special attention to underground high-voltage cables.

Close Observation on Dangerous Working Conditions

Keep a safe spacing between machine and edge of digging site. Do not dig the ground ahead of machine.

During the operations near a cliff or road curb, to ease the escape in any event, form a right-angle between tracks and cliff or road curb and place bulldozing blade in the front.

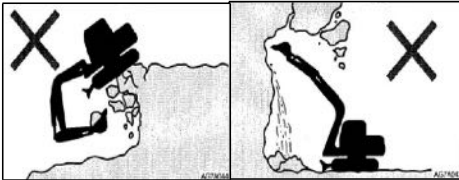

Never dig on the bottom of any high embankment. It's really dangerous because such operation may result in surface collapse.

Do not operate in any place with falling stone.

Do not access any soft ground area. This may result in inclination of machine due to dead weight and may cause rollover or ground entrapment.

Before operations on the top of any building or other structure, check the strength and structure. It will cause serious harm or destructions if the building or structure collapses.

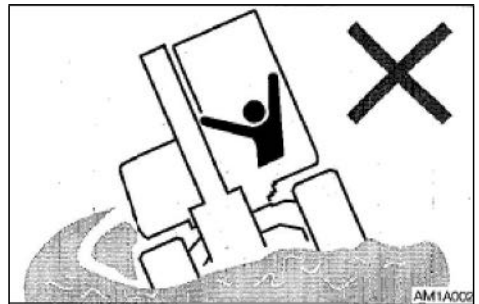

Keep away from unstable ground (Cliffs, road curbs, and deep ditches). If the ground collapses due to machine weight or vibration, there is a possible danger of machine falling or rollover. Please bear in mind that the soil turns infirm after heavy rain or explosion. The ground on the top of embankment and the ground around and on top of the dug ditches are also infirm.

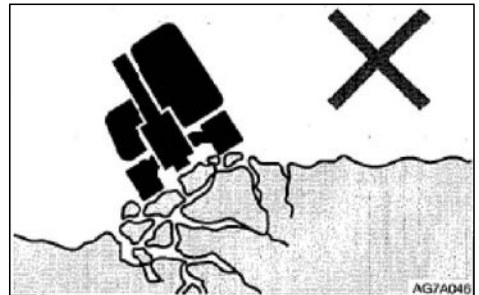

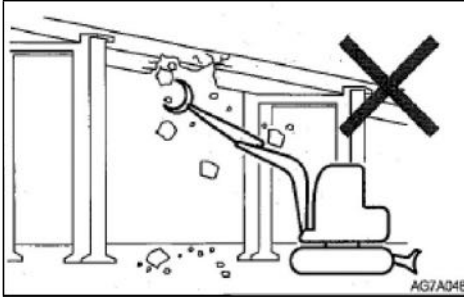

Do not perform demolition operations above your head. There is a risk of damaged parts or collapse danger of building to cause serious harm or destructions.

Do not perform demolition operations beneath the machine. There is a possible falling danger of machine when the ground becomes unstable.

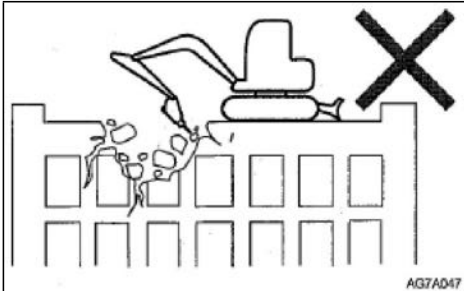

Do not perform the demolition operations by the impact force of bucket working device. The splashed material fragments and the damaged bucket working device have a danger of serious harm.

Danger during Operations on Slopes

During operations on slopes, slewing or operating the working device can probably result in instability or rollover of machine. Avoid operations on slopes whenever possible.

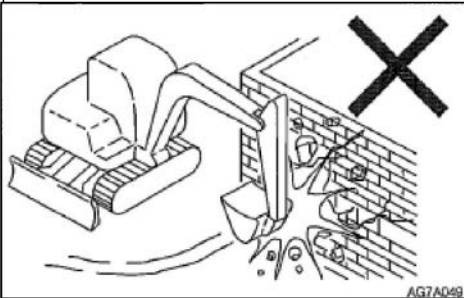

No Lateral Slewing (Swing) with Bucket Heavily Loaded

Leveling operation zone -Landfill

The machine is more vulnerable to rollover in lateral direction than longitudinal direction. Do not laterally slew (swing) when the bucket working device is heavily loaded. Especially,

do not laterally slew (swing) on a slope.

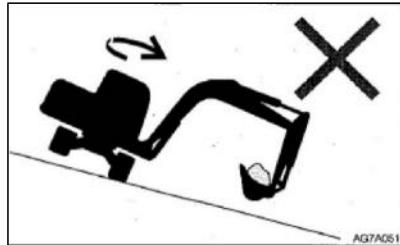
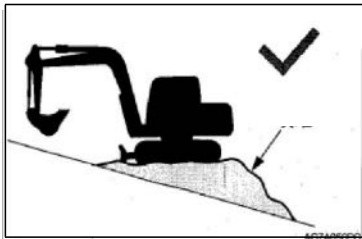

When the machine is equipped with breaking hammer, grinder, or extended bucket arm, the

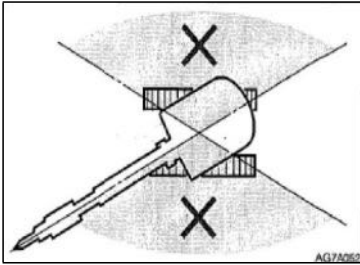

attachment end is heavier than that with standard bucket. For machine with such heavy end, do not face the bucket arm (boom) towards downslope direction for digging or towards lateral direction for operations.

If the bucket is fully loaded with material, avoid slewing towards the downslope direction. Otherwise, it will deteriorate the machine stability and probably result in rollover.

Guard against Overhead Objects

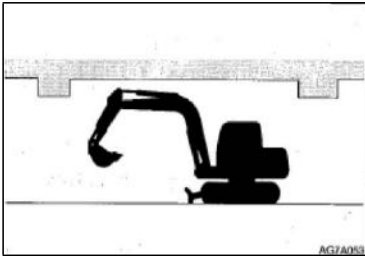

During operations under bridges, in tunnels, near cables, or indoors, guard the boom and bucket arm against impact with any overhead object.

Not Designed for Lifting Application

This machine is specially designed for digging operations. Therefore, it's not installed with safety devices for lifting operations. Take special caution while

using this excavator for lifting operations.

Do not overload during lifting. The overload will result in rollover of machine which may cause serious injuries or deaths.

All rated lifting capacities are based on the condition of using this machine on a firm and level ground. The user is recommended to reserve an appropriate allowance for specific working conditions, in order to ensure the safe lifting operations. The soft or uneven ground, non-level status, lateral load, dynamic or sudden load, dangerous environment, and personnel experience are included. Before operating the machine, the operation personnel and other personnel must be familiar with the Operation Manual. The safe operation regulations of the machine must be strictly followed in all cases.

If the chain or lifting device is incorrectly connected, the bucket connecting rod, or the lifting device may fail and could cause serious injuries.

While using this machine as a crane, do not attempt to pull out a stump from the ground. For this application, the load applied onto the machine is completely unknown.

Do not allow any person to stand on or beneath the lifted object or close to the operation zone.

Guard against Flying Objects

This machine is not installed with any protective device to guard the operator against the harm of flying objects. Do not operate this machine in any dangerous place in which the operator is probably subject to the impact of flying objects.

Precaution for Towing

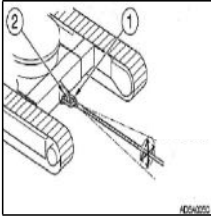

Please refer to the section “Towing” to understand more description information.

During towing, the improper operations, the incorrect use of rope, or the improper checking will cause serious injuries or deaths.

The breakage or cracking of rope can cause danger. Use wire ropes compatible with the towing force.

Do not use any kinked, twisted, or even damaged rope.

Do not suddenly apply heavy load onto the rope.

Please wear safety gloves during the handling of rope.

Ensure that an operator is assigned each on the towing machine and the towed machine.

Do not operate the towing operation on a slope. Keep all personnel away from the rope during towing.

Precaution for Parking

Safe parking

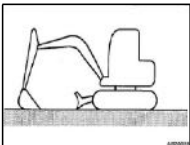

Stop the machine on a level, solid, and safe ground. Set the parking device.

Complete the following operations before leaving the machine:

Lower the bucket and bulldozing blade onto the ground.

Lift up the safety lock handle to the locking position.

Stop the engine and withdraw the starter key.

Lock the cab and hood and carry the key with you.

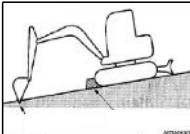

If it's necessary to park the machine or tilt the machine on a slope,

securely park the machine and block the machine against movement.

While parking the machine in a street, use gratings, warning signs, or lamps to keep the visible even in the night, in order to prevent the impact with other vehicles.

Precaution during Transport

Safe loading/unlocking of machine

The machine may roll over or fall off during loading and unloading. Ensure to take the following safety measures:

Select a solid and level ground and keep a sufficient spacing from the road curb.

Fix the ramps of sufficient strength and dimensions to the cargo body of truck. The inclination of the ramps shall not exceed 15°. If the ramps deflect downward excessively, please support the ramps by supports or cushion blocks.

Do not load or unload the machine by working device. Otherwise, it may result in rollover or falloff of machine.

Keep the truck cargo body and the ramps clean without oil, sand, ice/snow, or other impurity, in order to prevent the sideslip of machine. Clean the tracks.

Block the wheels of transport truck by wedges to prevent movement. While loading or unloading the machine, drive the machine slowly in 1st gear (low speed) as per the signals of the signaler.

Do not change direction on ramps.

Do not slew/swing on ramps. Otherwise, the machine may roll over.

Slewing (swinging) the machine on the cargo body of truck may result in unstable legs of machine. Therefore, operate slowly.

If possible, lock the cab doors after loading. Otherwise, the cab doors may open during the transport.

Plug securely the tracks by wedges and then fix the machine to the truck cargo body securely by ropes or chains.

Safe Lifting of Machine

Master and utilize the correct lifting gestures. Daily check the lifting device for damaged and missing parts and when necessary, replace. Please use the ropes of sufficient capacity for the machine weight during lifting.

Lift the machine as per the procedure described below. Do not operate by any other method, otherwise it may result in unbalance of machine. Please refer to the section "Lifting of Machine" to understand more description information.

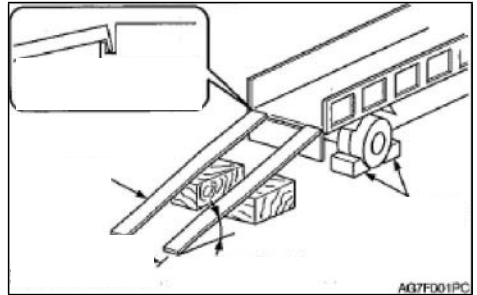

Do not operate the lifting if there is any operator on the machine.
Operate slowly during lifting to prevent the rollover of machine.
During lifting, keep all personnel away from working zone. Do not move the machine over any person.

Safe Transport of Machine

During the transport of machine, understand and abide by all applicable safety rules, vehicle codes, and traffic regulations.

Take the length, width, height, and weight of the transport truck with loaded machine into consideration, in order to select the best transport route.

During the transport, do not start up or stop the transport truck suddenly or drive at high speed. Otherwise, it will result in movement or unbalance of loaded machine.

Precaution for Maintenances

Warning Information of “No Operation” Sign

The checking or maintenances of machine, the start of engine or the touch of any joystick by non-authorized personnel may result in serious injury accidents. Before maintenances, please stop the engine and withdraw and carry the key.

Affix warning information “No Operation” to an eye-catching place such as starter switch and joystick.

Use of Correct Tools



Do not use any damaged or deteriorated tool or any tool designed for other application. Use tools suitable for related operations.

Periodically Replaced Critical Safety Parts Replace the fuel hoses periodically. The fuel hoses will wear gradually along with time, even if no wear symptom is visible.

Upon detection of any wear symptom, replace the fuel hose, regardless of the replacement schedule.

To understand more details, please refer to the section “List of Critical Safety Parts”.

Explosion-Proof Lamps

While checking the fuel, lubricating oil, coolant, and battery electrolyte, please use explosion-proof lamps to prevent fire and explosion. Otherwise, it may result in explosion to cause serious injury accidents.

No Access of Non-Authorized Personnel

During operations, the non-authorized personnel are prohibited to access the working zone. Take caution during grinding, welding, and use of hammer. You may be injured by the flying fragments from the machine.



Preparations of Working Zone

Select a stable and level working zone. Ensure the appropriate illumination conditions. For indoor operations, keep well ventilated. Remove obstacles and dangerous goods. Clear slippery areas.

Always Keeping Clean Machine

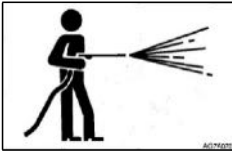

Please clean the machine before maintenances. Stop the engine before cleaning the machine. Cover the electric parts against water ingress. The water ingress into the electric parts may result in short-circuit or malfunction. Do not clean the battery, electronic control units, sensors, connector, or cab by water or steam.

Stop of Engine before Maintenances

While the machine is working, or the machine is not working but the engine is running, avoid lubricating or further adjusting the machine.

If the maintenance requires the running of engine, assign two operators for team work and keep contact with each other.

One operator must sit in the driver seat to get ready to stop the engine immediately when necessary. This operator must pay special attention not to touch any joystick or pedal, unless it's absolutely necessary.

The other operator for the maintenance must keep their body and clothing away from motion parts of machine.

Keeping Away from Motion Parts



Keep away from all rotating and motion parts. The entanglement of hands or tools into rotating or moving parts may cause accidents of serious injuries or even deaths.

The tools or other objects fallen or inserted into the fan or fan belt will be crushed or cut. Never throw or insert any object into fan or fan belt.



Secure Fixing of Machine and Possibly Falling Parts

Before the maintenances or repairs beneath the machine, lower all movable working devices onto the ground or lowest position and fix the tracks.

If it's necessary to operate beneath the lifted machine or device, always fix by cushion woods, jack, or other firm and stable supports. Do not access the area beneath the machine or working device before it's firmly supported. This operation is especially important for the hydraulic cylinder operations.

Fixing of Working Device

During the repairs and replacements of bucket teeth or side teeth, to prevent the accidental movement of machine, securely fix the working device.

Steady Placement of Opened Engine Hood and Cover

Before operations within the machine, please securely fix the engine hood or machine hood. Keep the engine hood or cover closed under windy weather or while parking the machine on a slope.

Placement of Heavy Weights at Steady Place



If it's necessary to place temporarily heavy weights or attachments onto the ground during disassembling or installation, please ensure to place them in a steady place. Keep the non-authorized personnel away from the place for storage of such objects.

Precaution for Refueling



Smoking and open fire are prohibited during refueling and near the refueling point. Do not disassemble the fuel tank cap or refuel while the engine is running or is not cooled down. Do not splash fuel to any high temperature surface of machine.

Refuel the fuel tank in a well-ventilated place. Do not top up the fuel tank. Leave an expansion space for the fuel.

Any overflowed fuel shall be wiped away immediately.

Tighten the fuel tank cap securely. If the fuel tank cap is missing, replace with original cap only. The use of non-

authorized fuel tank cap with poor ventilation will cause internal pressure in the fuel tank.

Do not use fuel for any cleaning purpose.

Use correct fuel grade based on the season.

Handling of Hoses

The leakage of lubricating oil or fuel can result in fires.

Do not distort, bend, or impact any hose.

Do not use any distorted, bent, or cracked pipeline, metal pipe, or hose, otherwise it may result in explosion.

Re-tighten any loose connector.

Caution during handling of High Temperature and High Pressure Parts

Please stop the engine and wait for the machine to cool down before maintenance.

The engine, exhaust pipe, radiator, hydraulic pipes, sliding parts, and many other machine parts are really hot when the engine is just stopped. Touching such parts can cause scalding.

The engine coolant, hydraulic oil, and other fluids are also under high temperature and high-pressure status.

Take caution not to touch the hydraulic oil while loosening engine hood or connector. Operating the machine under such condition will cause out-spray of hot oil to result in scalding or injuries.

Do not disassemble the radiator cap or drainage plug when the coolant is hot. Stop the engine and wait for the engine and coolant to cool down. Slowly loosen the radiator cap to relieve the internal pressure and then take it out.



Caution against Internal Oil Pressure

Take caution against internal oil pressure. After stopping, the pressure in the hydraulic oil pipes can hold for a long time.

Before the maintenances, thoroughly relieve the internal pressure.

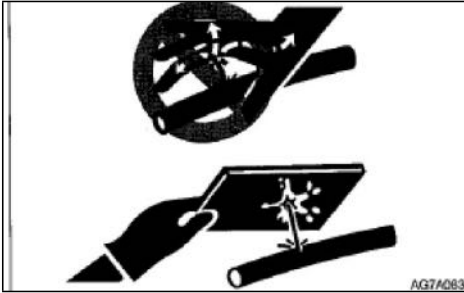

The high pressure of hydraulic oil can penetrate skin and eyes which may cause serious injuries and blindness or even death. Please bear in mind that the hydraulic oil permeating from orifices is nearly invisible to naked eyes. While checking for leakage, wear goggles and thick gloves and protect the skin by paper boards or plywood to protect against the harm of spraying hydraulic oil.

If hydraulic oil penetrating into your skin please consult your doctor or emergency department.

Pressure Relief before Operations of Hydraulic System

Disassembling cap or filter or disconnecting pipeline before the pressure relief of hydraulic system may result in out-spray of hydraulic oil.

- Slowly loosen the bleeding plug to relieve the pressure of oil tank.
- While disassembling connector or plug or disconnecting hose, stand on one side, loosen slowly to gradually relieve internal pressure, and then take out.
- The engine oil or oil plug may spray out under the internal pressure of traveling motor oil tank. Please slowly loosen the oil plug to relieve the internal pressure.

Guard against Splashed Fragments during Use of Hammer

During the use of hammer, the pins and the metal fragments may fly out. It may cause serious personal harm.

- While hammering hard metal parts such as pins, bucket teeth, side teeth, and bearings, please wear protective articles including goggles and gloves.
- While hammering pins and bucket teeth, ensure there is no person in surrounding area.

Guard against High Pressure Grease

In the track tensioner, the grease is injected under high pressure. If the tension is not adjusted by the following designated procedure, the grease relief valve may fly out to cause injuries.

- Never loosen the grease pipe fittings.
- Slowly loosen the grease relief valve. Do not rotate it for >1 turn.
- Do not place your face, arms, legs, or body in front of the grease relief valve.
- If no grease flows out when the grease relief valve is loosened, the valve is malfunctioned. Please contact your service dealer for repairs.

No Disassembling of Track Tensioner

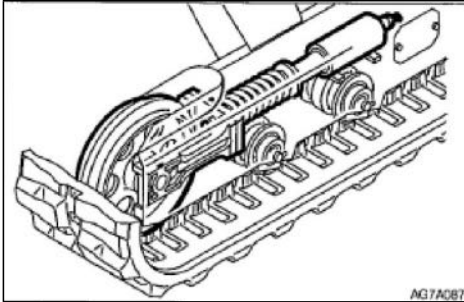

The track tensioner is installed with a high strength spring. If the track tensioner is disassembled carelessly, the spring will spring out to cause serious injuries. Do not disassemble the track tensioner.

Operations of Additional Devices

Take special caution while handling the high-pressure nitrogen stored in the tank. The improper handling may result in explosion of

nitrogen to cause serious injuries. Please strictly abide by the following safety measures:

- Do not break up or disassemble.
- Keep away from open fire and fire source.
- Never drill hole, weld, or melt.
- Guard against physical vibration, such as hammering, rolling, and falling.
- Bleed the sealed air before handling the cylinder body. If you need help, please contact your service dealer.

Disconnection of Battery Cables

Please disconnect the battery cables before operations or electric welding of electronic system. Firstly, disconnect the negative (-) cable of battery. During reconnection, finally connect the negative (-) cable of battery.

Caution during Handling of Battery

The battery contains sulfur acid. The accidental touch will harm your eyes or skin. In event of accidental contact with eyes, immediately flush by clean water and quickly seek for medical treatment.

In event of accidental swallowing, drink a lot of water or milk and immediately seek for medical treatment.

If the sulfur acid comes into contact with your skin or clothing, immediately flush by a lot of water.

Wear goggles and gloves during handling of battery.

The battery can generate inflammable hydrogen to probably cause explosion. Keep away from fire sources including open fire, spark, and ignited cigarette.



Use a flashlight to check the electrolyte level.

Ensure to turn off the starter switch and stop the engine before checking or handling battery.

Never touch the electrodes by any metal tool or object, in order to prevent short-circuit.

The loose electrodes can generate electric spark. Ensure to tighten any loose electrode.

Ensure that the battery cover is securely covered.

If the battery is frozen, do not charge the battery or attempt the jumper start of engine, otherwise it may cause explosion. Before use, heat the frozen battery to 15°C.

Do not use the battery when the electrolyte level is below the lower limit. Otherwise, it will speed up the internal aging and shorten the life of battery. In addition, it can lead to burst (explosion).

Do not fill the distilled water till the level is above the upper limit. Otherwise the electrolyte will leak out. The contact with such electrolyte can harm your skin or corrode the machine parts.

Clean the surrounding area of electrolyte level marking by a wet cloth and check the level. Do not clean by a dry cloth, otherwise it can cause electrostatic accumulation and combustion or explosion.



Periodically Replaced Critical Safety Parts

To guarantee the safe operation of machine for a longer time, add the oil and fulfill the checking and maintenances periodically. To promote the safety, periodically replace the critical safety parts, including hoses and seat belts. To understand more details, please refer to the section “Periodically Replaced Critical Safety Parts”.

“Periodically replaced critical safety parts” refers to the parts aged, worn, and functionally deteriorated after repeated use. The performances of such parts will change along with time. These characteristics of such parts can cause serious mechanical damages or personal harm and the remaining lives of such parts can’t be judged by merely appearance checking or operation hand-feel.

Upon detection of any visible damage on the appearance, please replace the “Periodically replaced critical safety parts”, even if the designated replacement period is not reached.

Jumper Start with Battery Charging Cable

To start the engine by battery charging cable, ensure to connect the cable correctly as per following procedure. The incorrect connection of cable can cause discharging and battery explosion.

Keep the “Malfunctioned machine” and “Rescue machine” away from mutual contact.

Never touch the positive (+) and negative (-) electrodes of battery charging cable with each other or with the machine.

During connection, firstly connect the positive electrode of battery charging cable to positive (+) terminal. During disconnection, firstly disconnect the negative (-) terminal (grounding terminal) from the negative cable.

Ensure to connect the cable clamps securely.

Connect the last clamp of battery charging cable to a place as far as possible from the battery.

To start the engine with battery charging cable, always wear goggles and gloves.

Use the battery charging cable and clamps of dimensions suitable to the battery capacity. Never use damaged or corroded battery charging cable or clamps.

Ensure that the battery capacity is same for the “Malfunctioned machine” and “Rescue machine”.

Asking Your Service Dealer for Welding Repair

The welding operations, if necessary, must be fulfilled by competent personnel in a working site with complete equipment. To prevent damaging any machine part by over-high current or electric spark, please abide by the following precaution.

- Disconnect the battery cables before electric welding.
- Do not apply 200V or higher voltage continuously.
- Connect the grounding point within 1m reach from the welding area. Do not connect the grounding terminal near the electronic control device/instrument or connector.
- Ensure there is no seal ring or bearing between welding area and grounding terminal.
- Do not connect the grounding terminal to the any place near the working device pin or hydraulic cylinder.
- Before the welding of machine body, disconnect the connector of electronic control device.

Vibration Applied on Operator

According to the results of the test on the vibration transmitted from the machine to the operator, the vibration applied on the operator’s upper limbs are $<2.5\text{m/s}^2$ and the vibration applied on the operator’s body in the seat is $<0.5\text{m/s}^2$.

Checking after Maintenance

Accelerate the engine speed slowly from low idling speed to fastest speed and check for leakage of oil or water from repaired parts.

Operate all joysticks and check machine for normal operations.

Waste Disposal



Ensure to collect the drained oil of machine into a container. The improper treatment of waste oil will pollute the environment.

While disposing harmful objects, including lubricating oil, fuel, coolant, solvent, filter, and battery, please abide by the applicable laws and regulations.

Disposal of Harmful Chemicals

The direct contact with harmful chemicals will cause serious harm. The harmful chemicals used in this machine include oils/greases, battery electrolyte, coolant, paint, and adhesive. Please dispose the harmful chemicals carefully and properly.

Safety Signs (Markings)

To guarantee the safety of operator and operation personnel in the working zone, please set up the following safety signs (markings) at some portions of machine. Walk around the machine with this manual and observe the contents and placement locations of these safety signs. Please review these signs and operation instructions contained in this manual jointly with the machine driver.

The safety signs shall be clean, clear, and easily legible. If any safety label falls, is damaged, or becomes illegible, please replace with new one.

If a part/body on which a safety sign is affixed is already replaced, affix a new sign to new part/body.

Safety Sign (Markings)

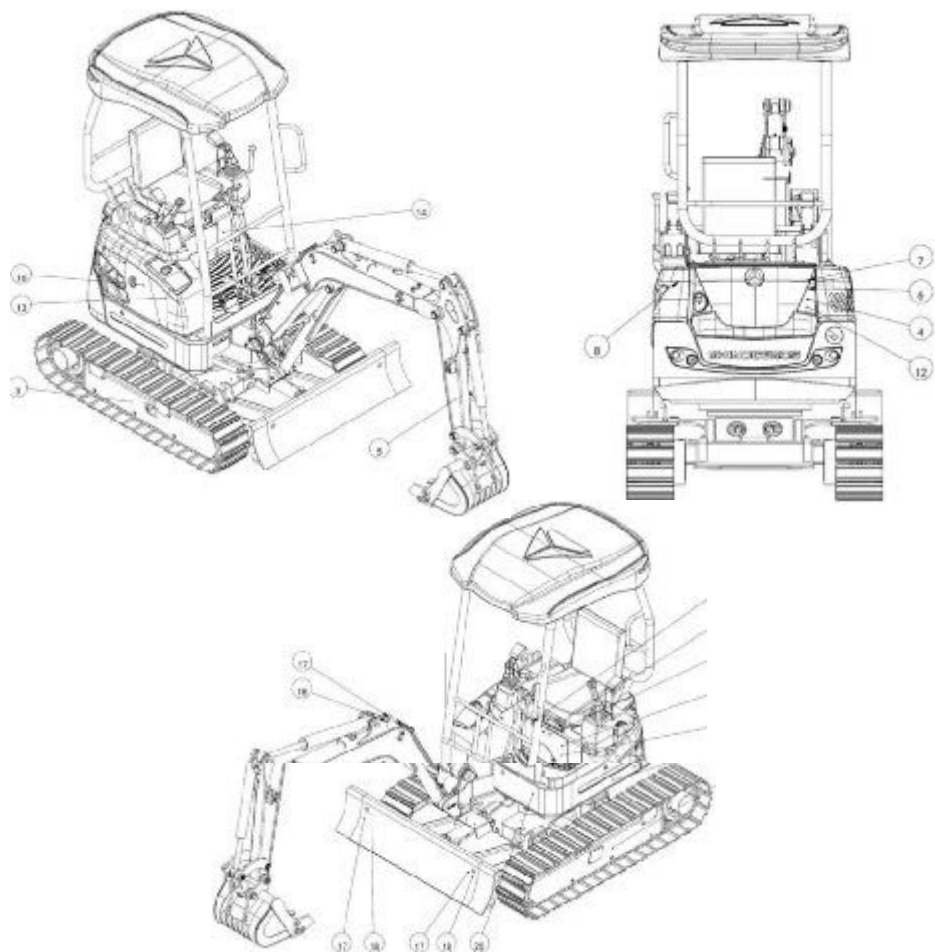

Warning Signs

Carefully read and understand the manual before operations, checking, and repairs of machine.

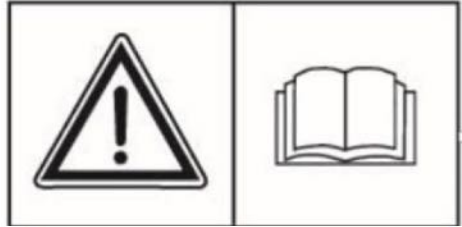

Safe distance.
Never approach to or stand in the working zone of machine.



Danger from underbody bolts thrown from track roller adjuster. To guarantee the safe and correct operations, ensure to read the operation manual before adjusting the track roller adjuster



Risk from rotating parts. Please turn off before checking and maintenances.



Safe distance and danger from collision with working device. Please keep away from machine during operations.



This sign denotes not to touch any hot part during operations or just after operations. Do not touch before these parts, including engine, pump, and exhaust pipe, are cooled down.



This sign denotes that the entanglement into steering belt can cause injury danger. Ensure that the steering belt completely stops rotation before maintenances or repairs.



This sign denotes that opening the radiator or hydraulic oil tank before its cools down may cause scalding risk by the spraying hot water or oil. Cool down the radiator or hydraulic oil tank before opening the cap.

Take special caution while driving over a slope or during operations on rugged road. If the lateral angle is $>10^\circ$, the machine will roll over. During the operations of machine, always adjust the tracks to the outer position. The inner position of the track

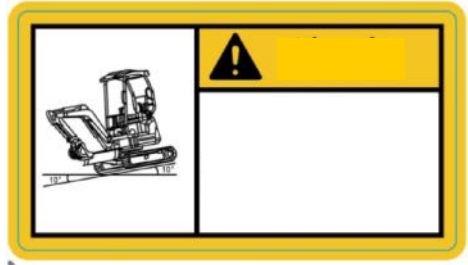

WARNINGS

If the machine is installed with an enlarged bucket, the cab may be impacted when the boom is at the maximum leftward deflection position.

The hydraulic oil tank must contain a certain pressure to prevent damaging the water pump. Refer to the instructions on the operation manual.

Take special caution while driving over a slope or during operations on rugged road. If the lateral angle is $>10^\circ$, the machine will roll over. During the operations of machine, always adjust the tracks to the outer position. The inner position of the tracks is only used for driving through narrow passages.

The operations or maintenances of this machine by incorrect method may cause injury. Before operating the machine, ensure to read and understand the operation manual attached in the machine.

Ensure that all safety facilities are ready and effective. Before operating the machine, please fasten your seat belt. Do not touch the joystick while getting on or off the machine, otherwise the parts may be damaged.

Lifting direction

Safety measures for lifting of machine.

When the machine is lifted, fix it by cushion blocks or supports. Do not operate beneath the lifted machine when the machine is not fixed by any support.

Keep the boom and bulldozing blade separated. While lowering the boom, take caution not to touch the boom with bulldozing blade.

Controls

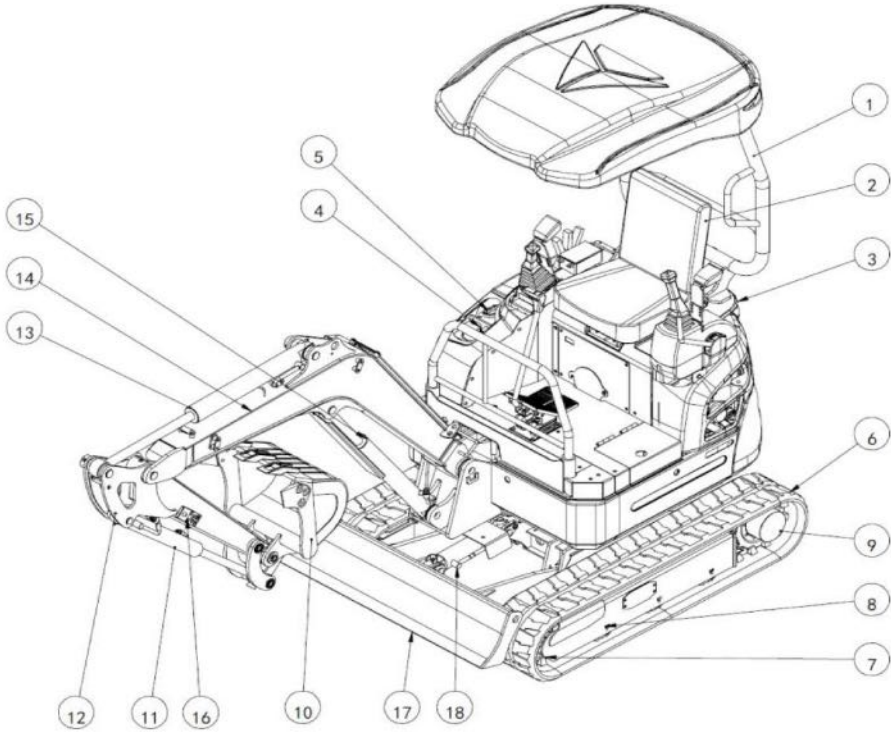

- | | | |
|-----------------------|--------------------|----------------------------------|
| 1. Top cover | 6. Tracks | 11. Bucket cylinder |
| 2. Seat | 7. Drive wheel | 12. Bucket arm |
| 3. Engine hood | 8. Track roller | 13. Bucket arm cylinder |
| 4. Fuel tank | 9. Traveling motor | 14. Boom |
| 5. Hydraulic oil tank | 10. Bucket | 15. Boom cylinder |
| | | 16. Auxiliary hydraulic pipeline |
| | | 17. Bulldozing blade |
| | | 18. Bulldozing blade cylinder |

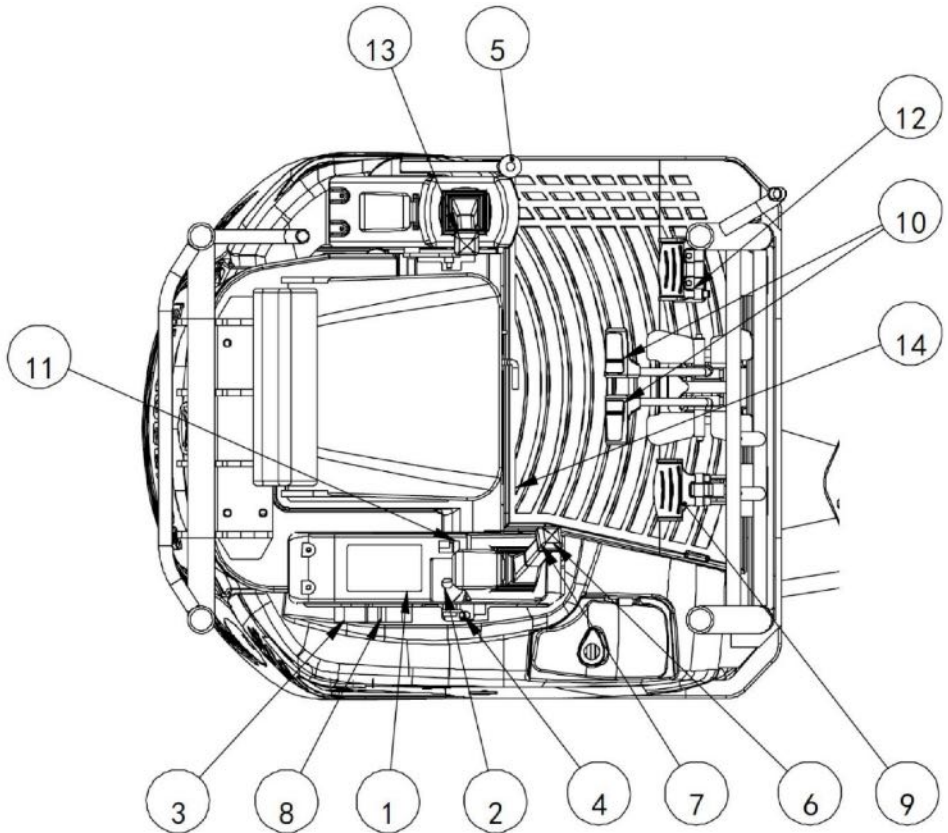

1. Electric control panel	8. Solenoid valve selector switch
2. Start switch	9. Boom swing pedal
3. Bulldozing blade joystick	10. Traveling joystick
4. Accelerator joystick	11. Traveling high/low speed switch
5. Safety lock handle	12. Auxiliary hydraulic pedal
6. Right joystick	13. Left joystick
7. Horn button	14. Lighting switch



Starter Key

The starter key is used to start the engine.

Fuse Case

This case is functioned to protect the electric system against over-current.

Access Panel

Opening

Before opening the access panel, ensure that the safety lock handle is at locking position and the engine is stopped.

This side gate is functioned to ease the repairs of side gate parts and the maintenance of battery.



Opening

1. Insert the key and rotate counterclockwise to unlock the access panel (1).

Closing

Close the access panel (1). Insert the key and rotate clockwise to lock the access panel (1)

pushing the lock bolt near the fuse cover.

Push inward the fuse covers (1) and (2) till the lock bolt is clamped in place.

Opening of Side Gate



Before opening the side gate, uplift the rubber mat of the front platform.

Then, open the small cap at this position of platform.

Fuel Tank Cap



Loosen the butterfly nut for several turns (but do not disassemble it).
Rotate upward this bolt.
While opening and closing the fuel tank cap, guard your hands against being pinched by the fuel tank cap.
Please open this cap for refueling.

Opening

Insert the key and rotate counterclockwise to unlock the fuel tank cap.

During the refueling into the fuel tank, keep away from heat source and open fire and do not smoke.

Refuel the fuel tank in a well-ventilated place. Stop the engine before refueling.

Any overflow fuel shall be wiped away immediately.

Do not top up the fuel tank. Leave an expansion space for the fuel.

Tighten the fuel tank cap securely.

Opening

Open the fuel tank cap.

Rotate fuel tank cap (1) counterclockwise to disassemble it.

Closing

Rotate the fuel tank cap clockwise to close it.

Close the fuel tank cap and lock it.

Engine hood

While opening or closing the engine hood, guard your hands and other body parts against being clamped by the engine hood.

Opening

Insert the key and rotate counterclockwise to unlock the engine hood.

Hook the lock handle by your index finger and push inward towards the lock hole by your thumb to open the engine hood.

Closing

Close the engine hood and push inward its edge till a click sound is heard.

Ensure to stop the engine before opening the engine hood. The entanglement of hands or tools into rotating or moving parts may cause serious injuries.

Seat and Seat Belt Seat

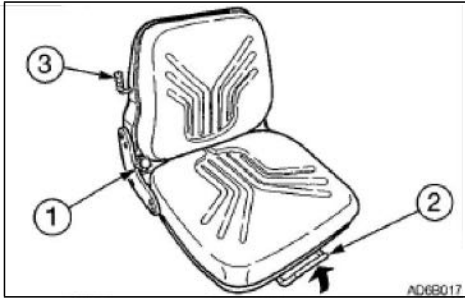

Tilting of Seat

Warning Adjustment and Fixing of Seats (For high-end seats only)

Backrest angle adjustment

Sit upright against the seat.

Use the rotary handle (1) to adjust the backrest to desired angle.

Longitudinal adjustment

Pull up the adjustment handle (2) and slide the seat longitudinally to the position you desired for operations of machine.

Loosen the adjustment handle (2) at your desired position to fix the seat.

Adjustment angle: 10 positions within 150mm.

Adjustment as per operator's weight

Move the adjustment handle (3) to set up as per operator's weight.

Opening

Manually pull forward this handle.

Tilt forwards the seat.

Closing

To close it, manually pull the handle, place level the seat, and then release the handle.

Seat Belt

Before starting the engine, please ensure to securely fasten the seat belt.

Adjust the seat to your desired operating position, sit uprightly in the seat, and lean backward your body.

Pull the seat belt to required length.

Ensure that the seat belt is not kinked and insert the seat belt tab (A) into the buckle (B), till a click sound is heard to indicate the secure locking.

Please pull the seat belt to check for secure locking and place the seat belt around your waist.

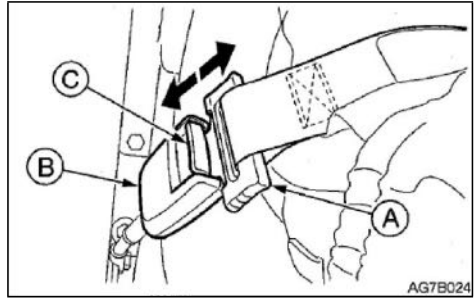
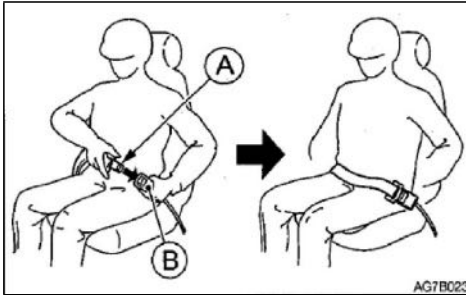

Release of Seat Belt

Hold the seat belt tab (A) and then push down the button (C) on the seat belt buckle. The seat belt retracts to its original position.

Records

Panel Name
and Description



S/N	Name	Description
1	Water temperature warning lamp	When the water temperature is >105°C, the warning lamp starts to flash and at the same time the buzzer sounds.
2	Fuel warning lamp	When the fuel level reaches 10%, the warning lamp starts to flash and at the same time the buzzer sounds.
3	Engine oil pressure indicator lamp	After the start of engine, if the engine oil pressure is too low, the warning lamp starts to flash and at the same time the buzzer sounds. In such case, stop the engine and check.
4	Charging indicator lamp	After the start of engine, if the green charging indicator lamp keeps on, it indicates the normal charging. If this lamp fails to turn on after start of engine, it indicates the abnormal charging. Stop the engine and check.
5	Preheater indicator lamp	If this lamp turns on, it indicates that the engine preheater is working. If this lamp is not on, it indicates that the preheater is not working.
6	High/low speed indicator lamp	If this indicator lamp turns on, it indicates that the system is under high-speed mode. If this indicator lamp is not on, it indicates that the system is under low-speed mode.
7	Water temperature gauge	It indicates the variation of coolant temperature in range of 40°C-120°C. The area from white zone to the red zone indicates the gradual increasing of temperature. When the red zone is reached, it indicates that the coolant temperature is too high. Stop the engine, wait for it to cool down, and then restart the engine.
8	Hour meter	It indicates the number of working hours in range of 0-99999.9h. It starts the timing after the start of engine. In such case, the ⌚ flashes.
9	Fuel gauge	It indicates the variation of fuel level in range of 10%-100%. The area from white zone to the red zone indicates the gradual increasing of fuel level. Generally, the fuel level varies within the green zone. If the red zone is reached, it indicates insufficient fuel in the fuel tank. Please refuel timely.

When the key switch is rotated to ON, the instrument starts the pre-working self-examination. In such case, all indicator lamps turn on, the pointers return to zero position, and the buzzer sounds. The system completes the self-examination in 3S and then enters the normal working mode. If the lamp fails to turn on, it indicates presence of malfunctions. Please contact local dealer or service personnel for careful checking.

Precaution

This instrument is a water-proof instrument, featuring stable performance and high conciseness and elegance, and is an intelligent instrument developed specially for small excavators. To guarantee the stable data and prolong the life of instrument, please notice the following issues:

Do not disassemble the instrument without permission.

Never brutally hammer or knock the instrument.

Guard against external damages.

Keep clean the panel. Any organic solvent or corrosive liquid, including diesel and gasoline, shall be timely wiped away, in order to prevent corroding the panel.

Should you have any question during use, please timely contact service personnel.

After-Service Information

Please carry this warranty certificate during the repair of this product and repair by a sales point of this device. Malfunction due to incorrect use of this device or non-authorized repair or modification of this device will not be covered under warranty.

Malfunction due to fire, earthquake, gas leakage, windstorm, thunder and lightning, and abnormal voltage will not be covered under warranty.

Switches Starter Switch

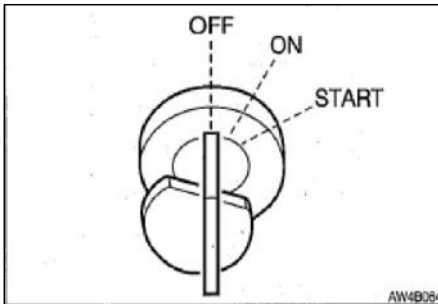

Important: Do not rotate the starter key from OFF to ON and then from ON to OFF repeatedly within a short time, otherwise it may result in engine malfunction.

OFF This position is used to stop the engine and insert and withdraw the starter key.

ON Engine running position. All electric devices are functional at this position.

START Engine running position. Upon release of key, the switch automatically returns to ON.

If the coolant temperature is too low, rotate counterclockwise the key, hold for 10~15s, and then release before start. Rotate the key to ON and then to START to start the engine.

Horn button

Press the switch on the right joystick to sound the horn.

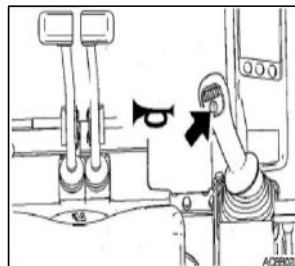

Traveling Speed Switch

The high/low speed switch is located beneath the right joystick support.

It indicates the high-speed mode when the indicator lamp turns on.

It indicates the low-speed mode when the indicator lamp turns off.



This device is functioned to lock the operations of bucket working device and machine slewing. When the handle is pulled up, the lock handle bracket pops up to lock the controls.

Accelerator joystick

It's used to control the engine speed.

(A) ... Low idling speed (B)... Maximum speed

Before starting operations, please carefully check and confirm the joystick mode to be used.

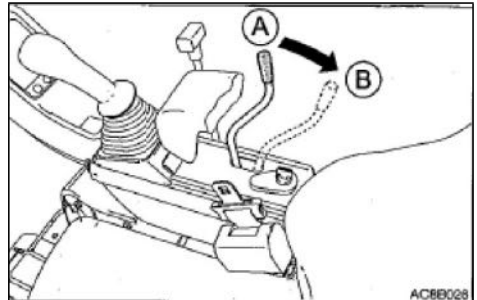
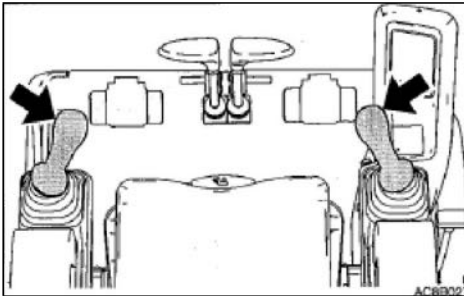

Control Mode

Bulldozing blade joystick

... Lift the bulldozing blade.

... Lower the bulldozing blade.

Traveling Joystick/Pedal

Before operating the traveling joystick/pedal, ensure that the bulldozing blade is in front of the driver seat. Please bear in mind that the operation direction of the traveling joystick/pedal with bulldozing blade behind the driver seat is reverse to that with bulldozing blade in front of driver seat.

Never place your foot onto the pedal, except the traveling operations. The accidental touch of the pedal during operations may cause sudden movement of machine to result in serious injuries.

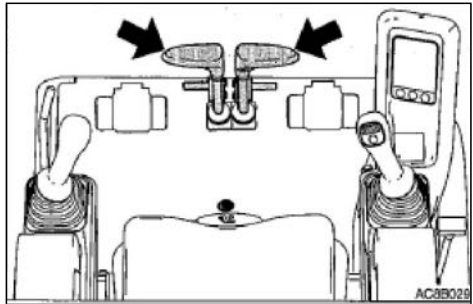
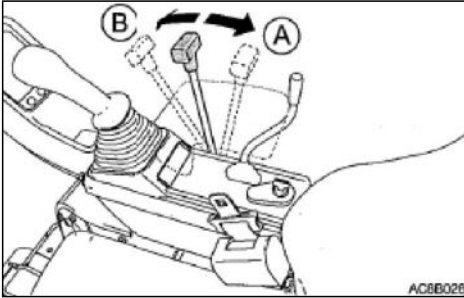

Use this joystick to operate the bulldozing blade.

Use this joystick/pedal to drive forward or backward and change the direction. Retract the pedal when it's not in use.

Boom swing pedal

When the pedal is not in use, hold the pedal cover at locking position. If it's not locked, accidental depressing of pedal may result in accidents.

Auxiliary hydraulic pedal

When the pedal is not in use, hold the pedal cover at locking position. If it's not locked, accidental depressing of pedal may result in accidents.

This pedal controls the hydraulic oil flow and direction in the auxiliary hydraulic circuit.

Tilt forward to lock the pedal. Tilt backward to unlock the pedal.

Use this pedal to swing the boom.

(A)...Rightward swing of boom

(B)...Leftward swing of boom:

Pedal Lock

Tilt forward to lock the pedal. Tilt backward to unlock the pedal.

Solenoid valve selector switch

This joystick has two buttons to switch over between change of track width and operations of bulldozing blade cylinder.

When pushed down, this joystick controls the telescoping of tracks.

When not pushed down, this joystick controls the lifting and lowering of bulldozing blade.

Auxiliary hydraulic pipeline

Disconnecting the pipelines before the pressure relief of hydraulic system may result in out-spray of hydraulic oil.

After stopping the engine, immediately press all auxiliary hydraulic pedals and 2nd auxiliary switch for several times to relieve the pressure in the auxiliary hydraulic circuit.

Slowly loosen the bleeding plug to relieve the internal pressure of hydraulic oil tank.

While disconnecting hoses, stand clear and loosen slowly. Slowly relieve the internal pressure before disassembling.

These pipelines deliver the hydraulic oil required for the operations of hydraulic breaking hammer, breaking hammer, and other working devices.

Connection of Hydraulic Circuits

To connect the attachment hydraulic pipeline, please operate as per following procedure:

Relieve the residual pressure from system and then close the shutoff valve. Refer to

Take out the connector.

Connect the attachment hydraulic pipes to ports (a/c) and (b/d). While installing a hydraulic breaking hammer, connect the oil inlet port to port (a) and oil return port to port (b).

Open the shutoff valve. While installing a hydraulic breaking hammer, open the selector valve (1).

After connections, fully bleed the air from hydraulic pipes.

Start the engine and run at low idling speed under no-load condition for 10min.

During the running of engine at low idling speed, operate the hydraulic auxiliary switch repeatedly (for approximately 10 times) to bleed the air from hydraulic pipes.

Stop the engine and wait for at least 5min, till the air bubbles overflow from the hydraulic oil in the oil tank.

Disconnection of Hydraulic Circuits

Relieve the residual pressure from system and then close the shutoff valve

Disconnect the pipelines from ports (a/c) and (b/d).

Install the connector.

Relief of Residual Pressure

The auxiliary hydraulic circuit still contains residual pressure after use. It's referred to as residual pressure. Please relieve the residual pressure after disconnection of pipelines.

After the stop of engine, depress the auxiliary hydraulic pedal from one side to other side for several times.

Before Start of Operations Getting on/off Machine

Warning

Do not jump on or off the machine. Do not attempt to get on or off a moving machine.

Before getting on or off the cab, firstly open the door completely to locking position and check and ensure that the door can't move further.



While getting on/off the footplates, hold the handrails to support your body weight and maintain three-point balance posture (Hands and feet) for your body. Do not use safety lock handle or any joystick as handrail.

Walk-Around Check

Before the first start of engine each day, fulfill one walk-around check.

Start and Stop of Engine Before Start of Engine

Adjust the seat to comfortable operating position.

Fasten the seat belt.

Check and ensure that the safety lock handle is at locking position.

Check and ensure that all joysticks and pedals are in neutral position.

Insert the key into starter switch, rotate to ON position, and then check as below:

All warning lamps turn on for 1s and the warning tone is issued for 2s. The instruments start working. After 2s, the engine oil pressure warning lamp (1) turns on and the other lamps turn off.

Press the lamp switch and check and ensure that the boom lamp, headlamp, and instrument lamp turn on.

If a lamp fails to turn on or a warning lamp fails to sound,

the lamp bulb or wire is probably damaged. Please contact your service dealer for repairs.

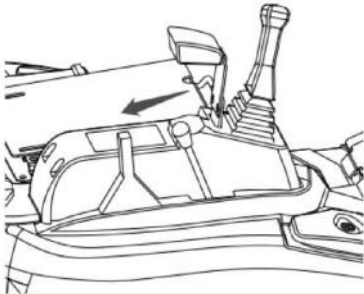

Start of Engine

Keep all personnel away from working zone.

Sound the horn to alert the personnel around machine.

Important: Do not run the starter motor continuously for >15s. If the engine fails to start, wait for 60s and then attempt to restart the engine.

Important: If the engine stops due to shortage of fuel, please add fuel, rotate the key to ON for 60s, and then rotate it to START position. Running the starter motor for a long time before the supply of sufficient fuel will cause start failure of starter motor.

Normal Start

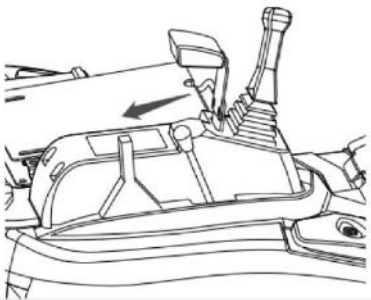

Pull the accelerator joystick to neutral position.

Rotate the starter key to START position to start the engine.

After the engine is started, release the key.

The key will automatically return to ON position.

Check and ensure that all warning lamps are already off.

Return the accelerator joystick and warm up the engine.

Start in Cold Weather

Never use starting fluid on this engine, as the starting fluid may explode.

Pull the accelerator joystick to neutral position.

Check and ensure that all warning lamps are already off.

Return the accelerator joystick and warm up the engine

Important: Before the completion of warm-up. Avoid the full speed running of engine. Do not warm up the engine for a long time (20min or longer). When the idling is required, occasionally apply the load or run the engine at medium speed.

Rotate the starter key counterclockwise to PREHEATER position for approximately 10s. The preheater indicator lamp turns on to indicate the running of preheater.

Rotate the key to ON, wait for the instrument lamp to turn off and the buzzer to stop sounding,

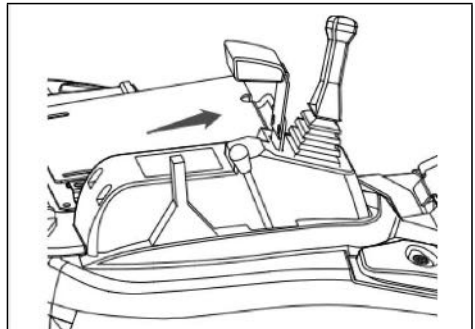

and then rotate the key to START.
After the engine is started, release the key.

The key will automatically return to ON position.

Return the accelerator joystick and then run the engine at low idling speed under no-load condition for 5min.

Stop of Engine

Important: Do not stop the engine suddenly under heavy load or during high-speed running. Otherwise, it will result probably in overheating or blockage of engine. Do not stop the engine hastily, unless in event of emergency.

Return the accelerator joystick.

Idle the engine for approximately 5min to stop the engine.

	Drive leftward		Drive rightward
	Back up to left		Back up to right
	Extend bucket arm		Lower boom
	Retract bucket arm		Lift boom
	Slew leftward superstructure		Load bucket
	Slew rightward superstructure		Dump bucket
	Swing leftward the boom		Lower bulldozing blade
	Swing rightward the boom		Lift bulldozing blade

Operations of Machine Joystick Mode (ISO Mode)

Before starting operations, please carefully check and confirm the joystick mode to be used.

Warm up the engine (hydraulic oil)

It's dangerous to operate the working device without warm-up (Hydraulic oil), as the working device can't respond quickly to the controls or will motion probably in unexpected manner and the safety devices can't work normally probably. Therefore, ensure to warm up the machine sufficiently.

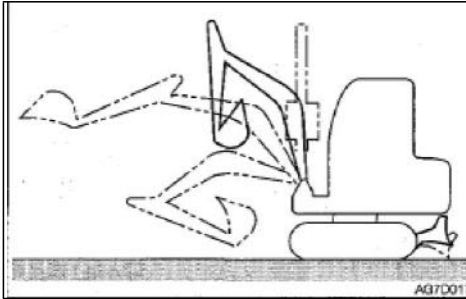

Completely lower down the safety lock handle to unlock and lift the bucket from the ground.

Important: When the hydraulic oil temperature is $<20^{\circ}\text{C}$, do not operate any joystick quickly. During the operations, the appropriate hydraulic oil temperature is $50\sim 80^{\circ}\text{C}$. If it's necessary to operate under low temperature, warm up the hydraulic oil to at least 20°C .

Normal Warm-up

Pull the accelerator joystick to neutral position. Then, run the engine at medium speed under no-load condition for approximately 5min.

Slowly telescope all cylinders for several times under no-load condition.

Slew slowly leftward and rightward for several times.

Drive forward and backward slowly for several times.

Warm-up in Cold Weathers

Fulfill the normal warm-up procedure.

After the warm-up of engine and machine (Hydraulic oil), check as per following procedure and when necessary, repair.

Check the warning lamps and instruments as below:

Whether all warning lamps turn off.

Whether the LED lamp of water temperature gauge is within green range.

Check for normal engine exhaust gas color, sound, and vibration.

Lift up the safety lock handle to locking position and check whether the operation and traveling joysticks are locked.

Change of Track Width

Always operate the machine with extended track width of 1,240mm, in order to improve the machine stability to the maximum extent. Operating the machine with narrow track width (990mm) may result in rollover of machine due to poor stability.

If it's necessary to operate the machine with narrow track width (990mm), retract the bucket working device and lower the boom to reduce the gravity center and face the machine towards front before traveling.

This machine can change the track width. Normally, to keep stable of machine, it's better to operate with extended track width.

Change of Track Width

Operate in a level and solid ground without obstacles.

Lift the machine body by bucket working device and bulldozing blade.

Important: Ensure to lift the machine body before the change of track width. Attempting the operation with tracks on ground may damage the side traveling frame or span cylinder.

Press the selector button and at the same time push the joystick.

Push forward the bulldozing blade joystick (B) to increase the track width (1,240mm).

Change of Bulldozing Blade Width

Loosen the bolts (1) and take out the pins (2).

Rotate the extension plate around the pins for 180°.

Install the pins and tighten the bolts.

Operations of Traveling Joystick/Pedal

Do not allow any person to access the turning radius or path of machine.

Sound the horn to indicate your movement intention.

There are blind zones behind the machine. To reverse the machine, if necessary, slew the cab to check the safety and ensure there is no person behind the machine.

Bulldozing blade

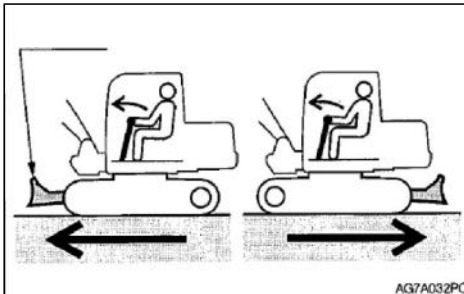

Before operating the traveling joystick/pedal, ensure that the bulldozing blade is in front of the driver seat. Please bear in mind that the operation direction of the traveling joystick/pedal with bulldozing blade behind the driver seat is reverse to that with bulldozing blade in front of driver seat.

Remove all obstacles from the path of machine.

Longitudinal Movement of Machine

Pull the accelerator joystick to increase the engine speed.

Completely lower down the safety lock handle to unlock.

Retract the bucket working device and lower to 30~40cm off the ground.

Lift the bulldozing blade.

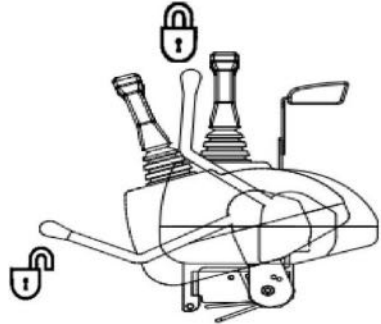

Operate the traveling joystick as per following procedure.

When the bulldozing blade is in the front of cab:

When the bulldozing blade is in the rear of cab: To drive forward:

Pull backward the joystick. To drive backward
Pull forward the joystick.

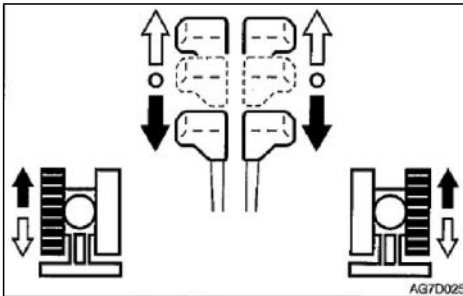
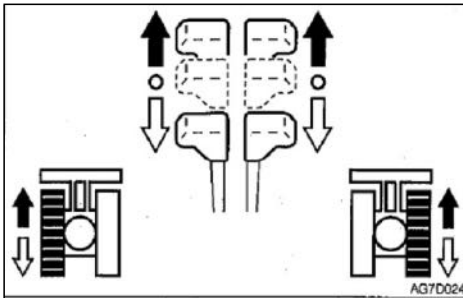

To drive forward:

Pull forward the joystick. To drive backward:

Pull backward the joystick.

Press this button to switch over between high speed and low speed.

Pivot Steering

Left turn during traveling:

To turn left during forward traveling: Place the left joystick to neutral position. When walking backward:

Place the left joystick to neutral position. To turn rightward during traveling, operate the right joystick by same operation method of left joystick.

In-situ Turnaround

Left turn under stopped status: To turn left the head:

Push forward the right joystick. To turn left the tail:

Push backward the right joystick.

To turn backward, operate the right joystick by same operation method of left joystick.

In-situ left turn:

Pull backward left joystick and push forward right joystick.

In-situ right turn:

Pull backward left joystick and push forward left joystick.

Stop of Traveling

Stop the machine on a level, solid, and safe ground. Set the parking device. If it's necessary to park the machine on a slope, block the track by wedges to prevent movement of machine.

When the safety lock handle is unlocked, accidental touch of any joystick will result in sudden movement of machine and may cause serious injuries.

Please note that, even if the safety lock handle is placed at locking position, the bulldozing blade, boom, and auxiliary hydraulic controls can't be locked.

Do not touch such controls accidentally

Slowly place the left and right traveling joysticks to neutral position. Stop the machine.

Operations of Working Device

Before starting operations, please carefully check and confirm the joystick mode to be used.

Do not stop the machine hastily, unless in event of emergency. Stop the machine at the optimal timing whenever possible.

Use the right joystick to operate the boom and bucket.

Use the left joystick to operate the bucket arm and slewing.

Return the joysticks to neutral position to stop the bucket working device.

Lower down the safety lock handle to the unlocking position.

Set the pedal cover to unlocking position.

Slewing

Before slewing, check the surrounding area for safety.

Lower boom:

Push forward the right joystick. Upper boom:

Push backward the right joystick.

Operations of Bucket Arm

Slew leftward superstructure: Push leftward the left joystick. Slew rightward superstructure: Push rightward the left joystick.

Operations of Boom

Retract bucket arm:

Push backward the left joystick. Extend bucket arm:

Push forward the left joystick.

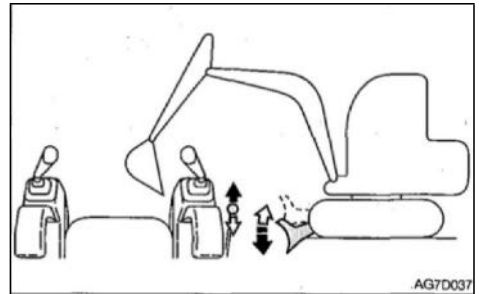
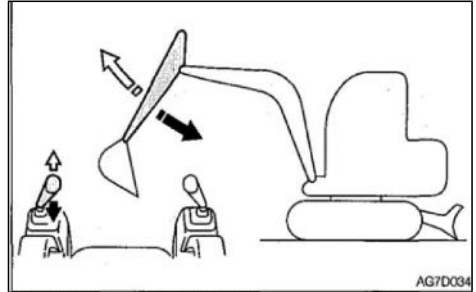
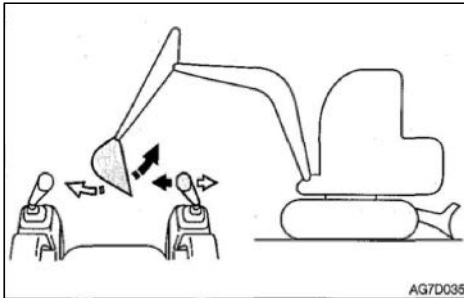

Operations of Bulldozing Blade

Load bucket:

Push leftward the right joystick. Dump bucket:

Push rightward the right joystick.

Swing of Boom

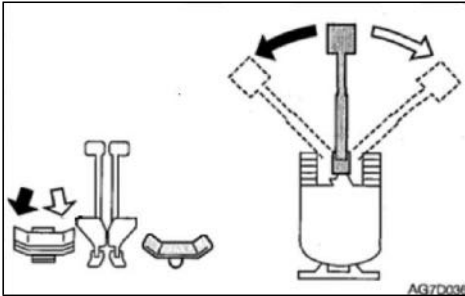

Lower bulldozing blade: Push forward the joystick. Upper bulldozing blade: Push backward the joystick.

Swing leftward the boom: Depress the left side of pedal. Swing rightward the boom: Depress the right side of pedal.

Prohibited Operations

Do not operate on a bed rock (Hard or soft).

Do not slew during the traveling. If it's necessary to operate the bucket working device during traveling, operate at sufficiently low speed to ensure the complete control at all times.

Do not use the slewing force for demolition or leveling operations.

No Digging during Traveling

Do not insert the bucket into the ground or use the traveling force for digging.

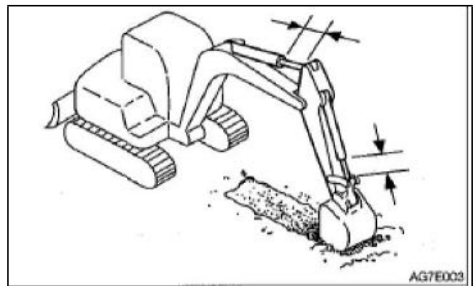
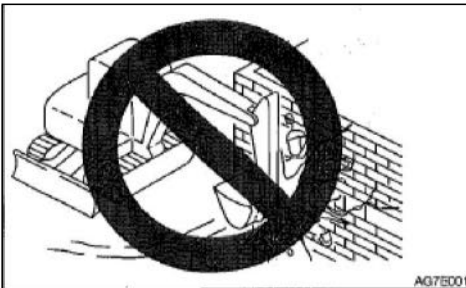

Do not use slewing force to dismantle walls or level ground. In addition, do not insert the bucket teeth into the ground during slewing. Otherwise, the bucket working device will be damaged.

Do not extend any hydraulic cylinder to the end. Reserve an allowance during operations. When the machine body is lowered and the bucket arm cylinder is completely extended, do not support the machine body by bucket working device. Otherwise, the load will be concentrated on the bucket arm cylinder to probably damage the bucket arm cylinder.

No Digging by Pulling or Hammering Bucket

Do not operate by the down force of machine.

This will shorten the life of bucket working device. Dig by hydraulic force.

Using additional tension onto the machine will shorten the life of machine. During digging, use the hydraulic force of cylinders by shallow depth and large travel.

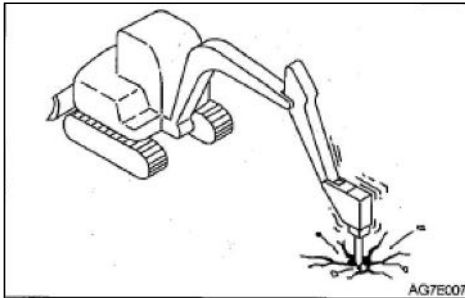

Digging of Bed Rock

For hard bed rocks, it's preferable to break the rock into small pieces by breaking hammer before digging. It can prevent the damages of machine and thus can be more economic.

Guard Bulldozing Blade against Impact

Prohibited Use of Bulldozing Blade as Support

Caution of Bulldozing Blade during Digging

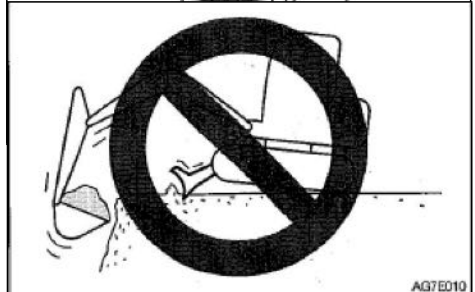
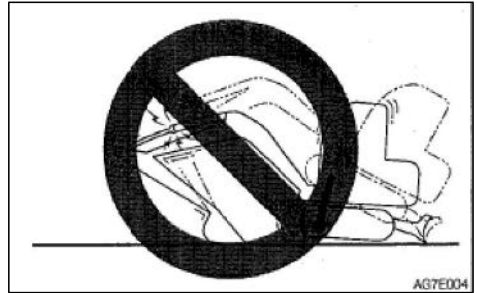

Impacting the bulldozing blade with rock will damage the bulldozing blade and bulldozing blade cylinder.

Careful Retraction of Bucket Working Device



While retracting the bucket working device, take caution not to impact the bucket with bulldozing blade.

For deep digging operations, if the bulldozing blade is in the front, take caution to prevent impacting the boom and bucket with bulldozing blade.

During operations, place the bulldozing blade on the rear of machine whenever possible.

Caution of Downward Digging with Bulldozing Blade
If it's necessary to drive over obstacles, close the

bucket working device to the ground, drive the machine at low speed, and drive the machine in such manner that the obstacles are in the middle of tracks.

Precaution for Traveling in 2nd Gear (High Speed)

This bulldozing blade is designed for simple bulldozing operations. Do not use the bulldozing blade for deep digging. Otherwise, the bulldozing blade and the underframe may be damaged.

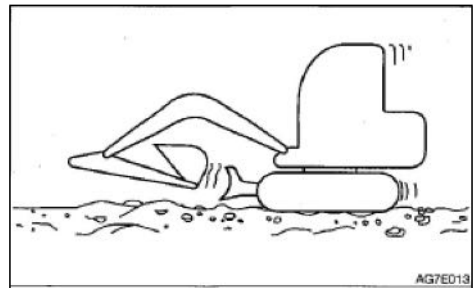
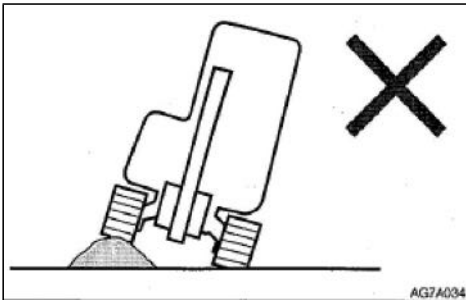

Driving the machine over obstacles (Including rocks and stumps) may apply high load onto the machine body and damage the machine. Avoid driving over obstacles

On rugged roads, drive the machine at low speed and avoid the sudden startup, stop, and direction change.

When the machine is traveling in 2nd gear

(High speed) and a load higher than set value is applied, the machine will automatically slow down to 1st gear (Low speed). If the load is reduced, the machine will accelerate and return to 2nd gear (High speed). Please be noted that the traveling speed varies depending on the load condition (For machine with automatic traveling gearshift reducer system).

Place the bulldozing blade in the front while traveling in 2nd gear.

Precaution for Operations of This Machine in Water

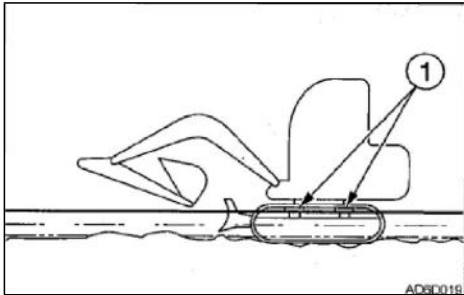

Immersing the rear of machine in the water as shown in above diagram will result in the rotation of radiator fan in the water to damage the fan. It's prohibited to immerse the rear of machine in the water.

Permissible water depth

Operate this machine in the water only when the water level is not above the middle of track shoe (1).

For those parts used in water for a long time,

add sufficient grease till the used grease is squeezed out.

Do not immerse the slewing support or body in the water or sand. If already immersed, please contact your service dealer for checking.

Precaution for Traveling on Slopes

Do not drive the machine on a slope steep enough to cause instability of machine.

Please be noted that, in the actual applications, the performances of machine on a slope will be deteriorated due to severe working conditions.

While traveling on a slope, lower the bucket to 20~30cm off the ground. While climbing up a steep slope, extend the bucket working device to the front position. In event of an emergency, lower the bucket onto the ground and stop the engine of machine.

While traveling on a slope, drive slowly in 1st gear (Low speed).

Keep the driver seat facing towards the upslope direction while climbing up a slope. Keep the driver seat facing towards the downslope direction during downslope traveling. In both cases, pay special attention to the ground ahead of the machine during traveling.

Do not reverse the machine down a slope.

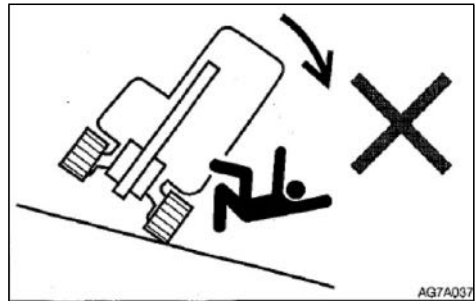

Traveling Posture on Slopes Upslope Traveling

Do not change direction on a slope or lateral slope. Firstly, return the machine to a level ground and then select another path.

The machine may slip laterally while traveling on a gentle slope covered by grass or dry leaves or traveling on a wet metal plate or frozen surface. Do not park the machine laterally on a

slope.

Downslope Traveling

While driving down a 15° or higher slope, reduce the engine speed and maintain the machine posture shown in above diagram.

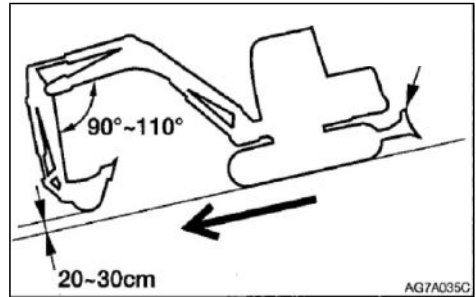
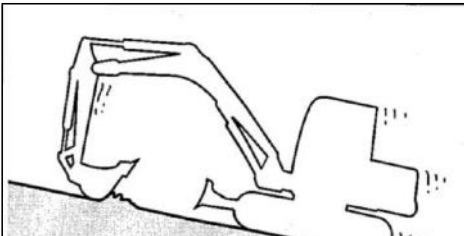
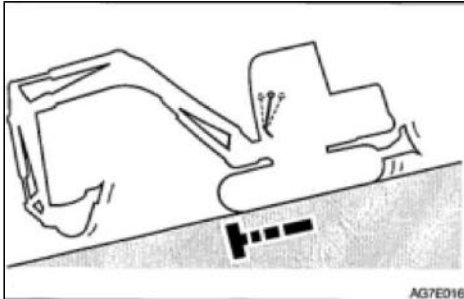

Braking during Downslope Traveling

While driving down a slope, the brake applies automatically after the traveling joystick returns to neutral position.

In event of traveling failure due to track slip while climbing up a slope, use the digging force of bucket arm to climb up the slope.

If the engine stops while driving down a slope, shift the traveling joystick to neutral position, stop the machine, and then start the engine.

No Opening of Doors during Traveling on Slopes
It's dangerous to open doors during traveling on slopes, as the force required to open or close doors changes suddenly. Please ensure to close doors securely while traveling on slopes.

Escape from Mud

If the machine is entrapped in the mud, Insert the bucket into the ground in the front of machine.

Pull the bucket joystick during forward traveling to slowly drive out the machine.

Swing the bucket towards the track entrapped in the mud.
Set the angles at $90\sim 110^\circ$ for bucket arm and boom.
Push the bucket bottom (Not bucket teeth) onto the ground.
Place a wood plate or similar object beneath the lifted track.
Lift the bucket and drive out the machine from the mud slowly.

Entrapment of Both Tracks in Mud

Place the bulldozing blade to the opposite side of the digging zone.

It's preferable to dig by shallow depth and large travel. The maximum digging force is achieved when the angle between boom and bucket arm is $80\sim 120^\circ$. It's preferable to change the angle for effective digging.

Loading

Install a bucket suitable for digging of ditches, adjust the tracks to be parallel with the ditch to be dug, in order to improve the working efficiency. While digging a wide ditch, dig the side faces and then the middle area.

Digging of Side Drainage Ditch

While loading soil into the cargo body of a truck, loading from the rear end of truck can load more soil easier than loading from the front end. In addition, the small angle slewing can be used to improve the efficiency.

Leveling

As shown in the diagram, dig the side ditch by swing function of boom.

Close the bucket working device to the machine body.

Slowly push away the soil from the side face of soil pile.

If the soil pile is low, push the soil from the top.

If the load is too heavy for the machine body, lift or lower the bulldozing blade for adjustment.

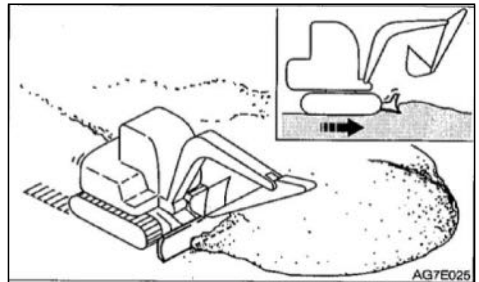
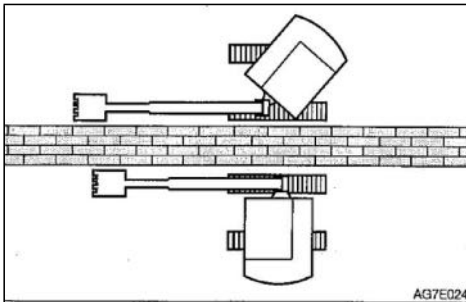

Parking of This Machine Parking

Before leaving the seat, lift up the safety lock handle to the locking position and stop the engine. Meanwhile, ensure to withdraw the key, close the doors and hoods, and carry the key with you.

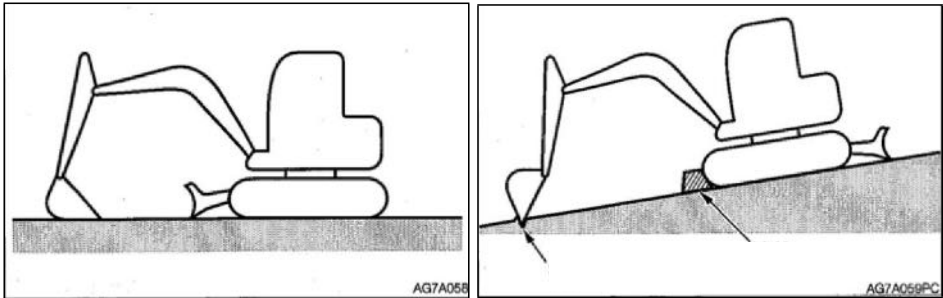

Stop the machine on a level, solid, and safe ground. Set the parking device.

If it's necessary to park the machine or tilt the machine on a slope, securely park the machine and block the machine against movement.

While parking the machine in a street, use gratings, warning signs, or lamps to keep the visible even in the night, in order to prevent the impact with other vehicles.

Place the left and right traveling joysticks to neutral positions.

Push backward the accelerator joystick to idle the engine.

Lower the bucket and bulldozing blade onto the ground.

Lift up the safety lock handle to the locking position.

Stop the engine and withdraw the key.

Checking after Stop of Engine

Check for leakage of oil and water and check the working device, cover, and underframe. Upon detection of any abnormality, repair.

Fully fill fuel.

Remove paper fragments and dusts from engine compartment.

Remove the mud from underframe.

Ensure to lock the following parts.

Fuel Tank Cap

Engine hood

Cover

Battery

The battery performance deteriorates along with the reduction of temperature.

Check the battery. Upon detection of battery discharging, please contact your service provider for advice.

Precaution after Operation

Please abide by the following precaution to prevent the movement failure of machine due to frozen mud, water, or underframe.

Remove all mud and water from machine body. Especially, wipe clean the hydraulic cylinder rod to prevent the ingress of rod surface mud and dusts into the seals along with water drops from damaging the seals.

Park the machine on a solid and dry ground. If impossible, park the machine on a ground paved with wood boards.

Fully drain the water from fuel tank to prevent freezing.

As the battery capacity will drop remarkably in low temperature environment, cover the battery or take the battery out of the machine and store it in a warm place. If the electrolyte level is too low, add distilled water before starting operations in the morning. To prevent the freezing of battery electrolyte at nighttime, do not add water after the daytime operations.

After Cold Weathers

When the weather becomes warm, fulfill the following operations.

Replace the fuel and lubricating oil

If the single-season type coolant is used, fully drain the cooling system, thoroughly clean the inside of cooling system, and then add running water.

Handling of Rubber Tracks

This machine is equipped with rubber tracks and the rubber tracks have their intrinsic weakness, namely low strength. Please ensure to abide by the following prohibitions and precaution to prevent damage and falloff of rubber tracks.

Driving the machine on a riverbed or place with numerous pebbles can probably result in inclusion of pebbles in the tracks and the damage or falloff of tracks.

Driving and steering the machine on gravels, rough and hard rocks, steel beams, or scrap irons or near the edges of steel plates will damage the rubber tracks.

Do not operate this machine by the sea. The salt content may corrode the steel core.

Keep the tracks away from the adhesion of fuel, lubricating oil, salt, and chemical solvent. These substances may corrode the welds of track steel cores to cause rusting or falloff. Such substances



adhered onto the tracks shall be immediately removed by water.

Driving the machine on irregular surfaces, such as new asphalt pavement and hot steel plates exposed to campfire or burning sun will result in irregular wear or damage of tracks.

Do not move the rubber tracks to possibly

Do not slew the underframe (The superstructure is not slewed) when the bucket working device is lifted in the front of machine body. Otherwise, the load will be concentrated at single point of tracks and the tracks will be twisted to cause rapid damage.

In all cases, avoid changing the route suddenly or avoid the in-situ steering on concrete surface whenever possible. Otherwise, the rubber tracks will be worn or damaged.

Avoid the strong impact onto the rubber tracks.

The tracks will be damaged by salt, potassium chloride, ammonium sulfate, potassium sulfate, and lime triple superphosphate. Such substances adhered onto the tracks shall be immediately removed thoroughly by water.

Keep both sides of rubber tracks away from friction with concrete or wall surface.

Do not impact the bucket with the rubber tracks, otherwise the tracks will be damaged.

Take special caution on snowy or icy surfaces in winter, as the tracks are vulnerable to slip on such conditions.

Please use rubber tracks within -25°C~55°C.

For long-time storage (≥ 3 months) of rubber tracks, please store in an indoor place without direct sun exposure or rainfall.

Guard against Falloff of Rubber Tracks

Always maintain an appropriate tension for the tracks.

When driving over pebbles or large steps (≥ 20 cm in depth, such as large rocks), climb on the steps in right angle and do not change route on steps.

The rubber tracks are not as stable as steel tracks, as they are completely made of rubber. Take special caution.

While reversing up a slope, do not change direction at the start point of slope.

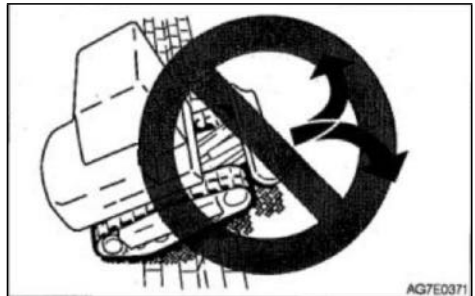

Please avoid driving the machine with one track on a slope or protrusion and the other track on level surface (In such case, this machine is inclined by 10° or more). Please drive the machine with both tracks on level surface. Do not change the direction when the tracks are loose.



Transportation Loading and Unloading

The machine may roll over or fall off during unloading. Ensure to take the following safety measures:

Select a solid and level ground and keep a sufficient spacing from the road curb.

Fix the ramps of sufficient strength and dimensions to the cargo body of truck. The inclination of the ramps shall not exceed 15°. If the ramps deflect downward excessively, please support the ramps by supports or cushion blocks.

Do not load or unload the machine by working device. Otherwise, it may result in rollover or falloff of machine.

Keep the truck cargo body and the ramps clean without oil, sand, ice/snow, or other impurity, in order to prevent the sideslip of machine.

Do not slew/swing on ramps. Otherwise, the machine may roll over.

Slewing/swinging the machine on the cargo body of truck may result in unstable legs of machine. Therefore, operate slowly.

If possible, lock the cab doors after loading. Otherwise, the cab doors may open during the transport.

Plug securely the tracks by wedges and then fix the machine to the truck cargo body securely by ropes or chains.

Block the wheels of transport truck by wedges to prevent movement.

While loading or unloading the machine, drive the machine slowly in 1st gear (low speed) as per the signals of the signaler.

Do not change direction on ramps.

Securely apply the parking device of transport truck and block the wheels by wedges.

Place the ramps securely onto the truck cargo body. The inclination of the ramps shall not exceed 15°.

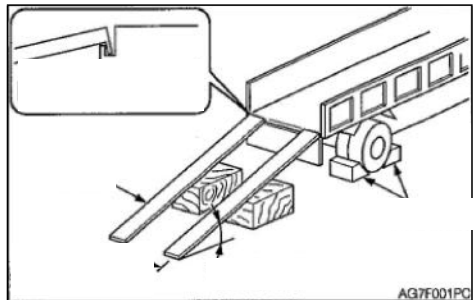

Align the center of truck cargo body with the center of machine and align the center of ramps

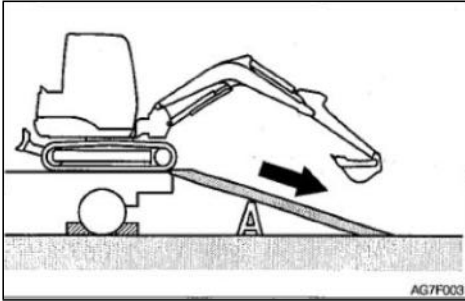

with center of tracks.

Ensure that the bulldozing blade will not touch the ramps.

Lower the bucket working device as low as possible and take caution not to impact it with the transport truck.

Reduce engine speed.

transport truck.

According to the signaler's signals, drive the machine straightly up or down along the ramps in 1st gear (low speed). Load the machine to designated position

Lifting of Machine

Daily check the lifting device for damaged and missing parts and when necessary, replace.

Please use the ropes of sufficient capacity for the machine weight during lifting.

Lift the machine as per the procedure described below. Do not operate by any other method.

This is really dangerous as it may result in imbalance of machine.

Do not operate the lifting if there is any operator on the machine.

Operate slowly during lifting to prevent the rollover of machine.

During lifting, keep all personnel away from working zone. Do not move the machine over any person.

Important: This lifting method is applicable for the models with standard overall parameters. The gravity center varies depending on the installed attachments and optional devices.

To understand more details, please contact your service dealer.

Lifting

Slew the superstructure to place the bulldozing blade behind the machine (Adjust the superstructure to be parallel with track frame).

Lift the bulldozing blade to highest position.

Sufficiently extend the bucket cylinder and bucket arm cylinder and lift the boom to highest position.

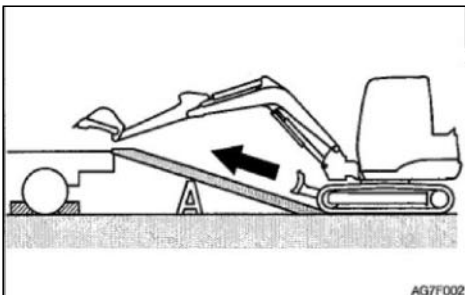

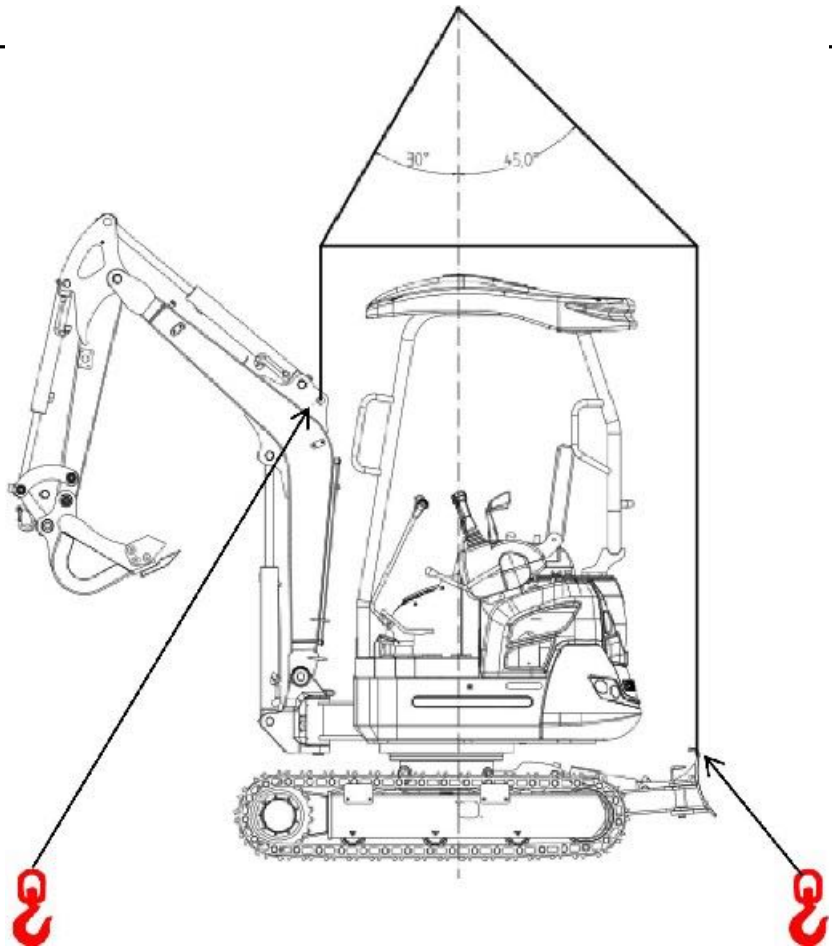

If the boom swings leftward or rightward, adjust it to neutral position.

Raise the safety lock control lever to the locking position.

Stop the engine, withdraw the starter key, and leave the machine.

Install the ropes as shown in diagram below. Install the ropes and lifting appliance and take caution to keep them away from machine body.

Slowly lift the machine, till it's off the ground.

Stop the lifting till the machine becomes stable and then lift the machine again.

Fixing of Machine

After loading the machine to designated position, fix as per following requirements.

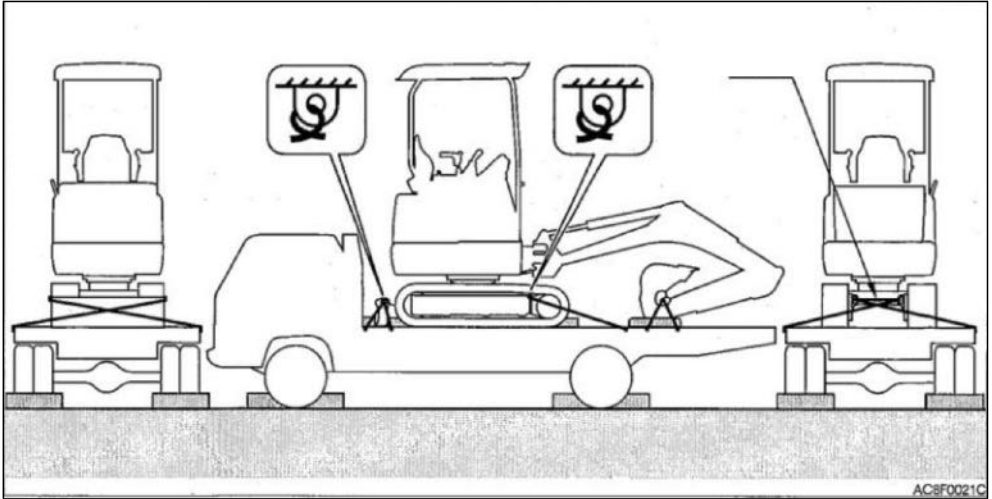

Lower the bulldozing blade.

Sufficiently extend the bucket cylinder and bucket arm cylinder and then lower the boom.

Lift up the safety lock handle to the locking position.

Stop the engine, withdraw the starter key, and lock all locks.

Place the stop blocks (Wedges) on the front and rear of tracks.

Affix chains or ropes securely to the lower framework of machine, in order to prevent the sideslip of machine.

Fix the bucket by chains or ropes.

Safety Measures Taken during Transport

During the transport of machine, understand and abide by all applicable safety rules, vehicle codes, and traffic regulations.

Take the length, width, height, and weight of the transport truck with loaded machine into consideration, in order to select the best transport route.

During the transport, do not start up or stop the transport truck suddenly or drive at high speed.

Otherwise, it will result in movement or unbalance of loaded machine.

Maintenance

To maintain the good status and long-term serviceability of the machine, please fulfill the checking and maintenances correctly and safely abide by the procedures recommended by this manual.

Based on the total operating time of the machine, the checking and maintenance items can be divided into several groups: Every 10h (Walk-around checking and daily routine checking), every 50h, and every 250h. Please refer to the reading of hour meter to determine the checking and maintenance timing. The items for which the checking and maintenance intervals can't be determined are listed in column "As necessary".

When the machine is operated in extremely severe environment (Dusty or high temperature environment), fulfill the checking and maintenance ahead of the periods specified by maintenance schedule.

Maintenance Precaution

Do not fulfill any other checking or maintenance item not listed in this manual.
For the items not listed in this manual, please ask your sales or service dealer for help.

Keeping Machine Clean

Clean the machine before checking and maintenance.

Keep the machine clean.

Stop the engine before cleaning the machine.

Cover the electric parts against water ingress. The water ingress into the electric parts may result in short-circuit or malfunction.

Do not clean the battery, electronic control units, sensors, connector, or operating room by water or steam.

Fuel, Lubricating Oils, and Greases

Use the water-free fuel, lubricating oil, and grease. Take caution to eliminate the ingress of dusts during replacement or filling of fuel, lubricating oil, and grease.

Store the fuel, lubricating oil, and grease in designated location and guard against the ingress of water and dusts.

Precaution for Refueling

If the fuel filler port is installed with a filter screen, do not remove the filter screen during refueling.

Please ensure to tighten the fuel tank cap after refueling.

The refueled volume shall not exceed the designated fuel volume.

No Cleaning of Engine Parts by Fuel Use non-flammable detergent.

Guard against Ingress of Dusts

The installation and disassembling of parts shall be operated in a dust-free place. Clean the

working area and clean the parts to guard against ingress of dusts.

Cleaning of Mounting Surfaces

Keep clean the contact surface of parts during the installation and disassembling. If the sealing grooves of the contact surfaces are damaged, please contact your sales or service dealer for repairs or breakup.

Seal Rings and Split Pins

Ensure to replace all disassembled seal rings and split pins with new ones.
Take caution not to damage or twist any seal ring during installation.

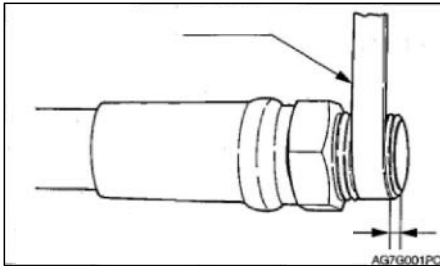

Leave 1~2 turns of threads not wrapped with seal ring.

While wrapping the screw plug with seal ring tape, thoroughly remove the used seal ring tap from the threads and clean the threads.
Wrap the threads with seal ring and notice to leave 1~2 end threads of screw plug not wrapped with seal ring.

Waste Disposal

Ensure to collect the drained oil of machine into a container. The improper treatment of waste oil will pollute the environment.

While disposing harmful objects, including lubricating oil, fuel, coolant, filter, and battery, please abide by the applicable laws and regulations.

Checking after Maintenance

Accelerate the engine speed gradually from idling speed to fastest speed and check for leakage of oil or water from repaired parts.

Operate all joysticks and check machine for normal operations.

Precaution for Wire Connections of Battery

Before operating the electronic system or performing electric welding, disconnect the wires from both electrodes (+ and -) of the battery.

Ensure to disconnect it from the grounding electrode (-). Finally connect the grounding electrode during connection.

Do not disconnect the battery wires during the normal running of engine. Otherwise, the rotary converter circuit or other parts may be damaged.

Service Data

Fuel and Lubricant Table

Please refer to following table to select appropriate fuel, lubricating oil, and grease based on the temperature.

Regardless of the specified periods, replace the oil when the oil is too dirty or already deteriorated.

Never mix the oils of different trademarks while adding fuel/oil. To replace with fuel/oil of another trademark, please replace completely.

Fuel Specified fuel

The diesel shall meet the following specification. This table lists some diesel specifications available in the world.

Diesel specification	Region	Diesel specifications	
GB252	China	JIS K2204, grade 2	Ja
ASTM D975 No. 1-D, S15 No. 2-D, S15	USA	ISO 8217DMX	W
Bio-diesel mixture B5 ASTM D6751, D7467			
EN590: 2009 Biodiesel Bio-diesel mixture B5 EN14214, EN590	EU	BS2869-A1 or A2	U

Fuel tank	Diesel	<p>To maintain the performance and life of engine, please always use clean and high-quality fuel.</p> <p>To prevent freezing in cold weathers, please choose diesel still suitable when the actual temperature is less by at least 12°C than the expected minimum outside temperature.</p> <p>Please use diesel with cetane number at 45 or higher. During the operations in low temperature or high-altitude regions, use fuel of higher cetane number.</p> <p>Use fuel with sulfur content (volume ratio) at <0.5%.</p> <p>Use ultra-low sulfur fuel especially in U.S. and Canada.</p> <p>The use of fuel with high sulfur content can probably result in sulfur acid corrosion in engine cylinders.</p> <p>Do not mix the diesel with kerosene, used engine oil, or residual fuel. It's prohibited to use kerosene.</p> <p>The low-quality fuel will reduce the engine performance and/or damage the engine.</p> <p>It's not recommended to use fuel additives. Some fuel additives will deteriorate the engine performances.</p> <hr/> <p>Safety measure for use of biodiesel</p> <p>The warranty regulation of the engine manufacturer is void for the engine using disqualified or deteriorated biodiesel.</p>
-----------	--------	--

Lubricant

Position	Type	Type depending on temperature -20 -10 0 10 20 30 40°C	Replacement period
Oil sump	Diesel engine fuel API: grade CD ACEA: E-3, E-4 or E-5		First 50h * Afterwards every 250h
Hydraulic oil tank	Anti-wear hydraulic oil		Every 2000h ***
Cooling	Coolant (Water + coolant)	50% coolant mixture	Every

system	**			30% coolant mixture	1000h
Traveling reducer gear	SAE: J814C or J1034 Gearbox API: GL-4		SAE 90		First 250h * Afterward
Slewing motor gear	Lithium-base grease EP-2				Every 50h
Slewing bearing	MLGI 2#				Every 50h
Working device					Daily or every 10h
Arm					As necessary

*: If the traveling time accounts for a high ratio of the total operating time, replace the gear oil ahead of the specified periods.

** : Use running water (soft water). Do not use well water or river water. If the outside temperature is <0°C, add coolant (antifreeze). Determine the mixture ratio as per the coolant manufacturer's instructions.

***: The replacement period of hydraulic oil depends on the type of hydraulic oil in use. The new machine is filled with genuine hydraulic oil 46 at the time of delivery and the hydraulic oil replacement periods described in this manual are based on the use of genuine hydraulic oil 46. When common anti-wear hydraulic oil is used, replace the hydraulic oil once every 2,000h.

Periodical Replacement of Hydraulic Oil

With installed hydraulic breaking hammer, the hydraulic oil deteriorates faster than the common digging operations. Ensure to replace the hydraulic oil and oil return filter element.

The failure to replace timely will result in damage of machine and breaking hammer hydraulic system. To prolong the lives of hydraulic devices, please timely replace the hydraulic oil and oil return filter element as per the table below.

During the replacement of hydraulic oil, clean the oil suction filter screen.

Replacement period (Hour)

Hydraulic device replacement period

Filter replacement period

Breaking hammer operating ratio (%)

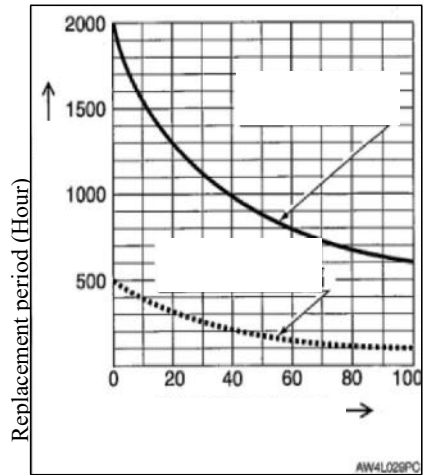

(): For the use of common anti-wear hydraulic oil.

Item	Hydraulic oil	Filter element
1 st time	--	25
2 nd time	--	100
Periodic	1200(600)	200

List of Wearing Parts

Periodically replace the wearing parts, including filters and filter elements, as per the table below.

System	Item	Part name	Replacement period
Hydraulic system	Hydraulic oil return filter	Filter element	Replace after first 50 hours, then every 500 hours
Hydraulic system	Ventilator		Every 1000h
Engine lubrication system	Engine oil filter	Filter cartridge	Replace after first 50 hours, then every 500 hours
Fuel system	Water separator	Filter element	Every 500h
	Fuel filter	Filter cartridge	Every 250h
Air filter system	Air filter	Primary (Outer) filter element	Every 1,000h or 6 cleaning cycles (Whichever comes first)
		Secondary (Inner) filter element	At replacement of primary element

List of Tools (If installed)

List of tools				
S/N	Name and specification	Unit	Quantity	Remark
1	Toolbox	PCs	1	
2	Socket hex. wrench (4mm)	Piece	1	
3	Socket hex. wrench (5mm)	Piece	1	
4	Socket hex. wrench (6mm)	Piece	1	
5	Socket hex. wrench (8mm)	Piece	1	
6	Socket hex. wrench (10mm)	Piece	1	
7	Socket hex. wrench (12mm)	Piece	1	
8	Stud dead spanner 22*24	Piece	1	
9	Stud dead spanner 27*30	Piece	1	
10	Stud dead spanner 30*32	Piece	1	
11	Stud dead spanner 36*41	Piece	1	
12	Combination wrench, 8mm	Piece	1	
13	Combination wrench 10mm	Piece	1	
14	Combination wrench 12mm	Piece	1	

15	Combination wrench 13mm	Piece	1	
16	Combination wrench 14mm	Piece	1	
17	Combination wrench 15mm	Piece	1	
18	Combination wrench 16mm	Piece	1	
19	Combination wrench 17mm	Piece	1	
20	Combination wrench 18mm	Piece	1	
21	Combination wrench 19mm	Piece	1	
22	Socket head, 10mm	Piece	1	
23	Socket head 11mm	Piece	1	
24	Socket head 12mm	Piece	1	
25	Socket head 13mm	Piece	1	
26	Socket head 14mm	Piece	1	
27	Socket head 15mm	Piece	1	
28	Socket head 16mm	Piece	1	
29	Socket head 17mm	Piece	1	
30	Socket head 18mm	Piece	1	
31	Socket head 19mm	Piece	1	Extended socket head
32	Socket head 21mm	Piece	1	
33	Socket head 22mm	Piece	1	
34	Socket head 24mm	Piece	1	
35	Socket head 27mm	Piece	1	
36	Socket head 30mm	Piece	1	Changed to 30mm
37	Curved extension rod, 12.5mm	Piece	1	
38	Short extension rod, 12.5mm	Piece	2	One long and one short each
39	Wire cutter, 200mm	Piece	1	
40	Nipper pliers, 200mm	Piece	1	
41	Ratchet wheel handle, 12.5mm	Piece	1	
42	Adjustable wrench, 300mm	Piece	1	
43	Ball hammer, 1.5pon	Piece	1	
44	Straight screwdriver, 200mm*8mm	Piece	1	
45	Phillips's screwdriver, 200mm*8mm	Piece	1	
46	Grease gun, 400g	Piece	1	
47	Belt wrench, 60-140mm	Set	1	

Table of Tightening Torques

Nuts and Bolts (Grade ISO10.9)

Unless otherwise specified, tighten the nuts and bolts to the torques listed in table below.

The tightening torques for installation of plastic caps are not listed in the table below. To understand more details, please consult with your sales or service dealer. The excessive tightening torque will cause damages.

If the replacement is required, replace with nuts and bolts of same dimensions and specifications.

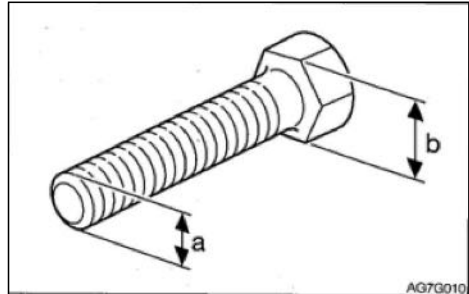
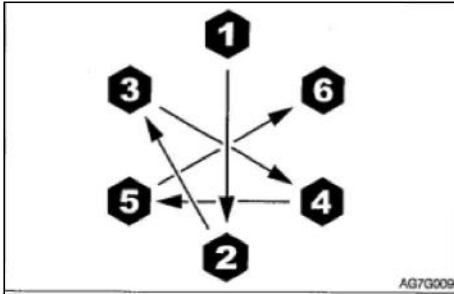

Category	Width across flats (b) mm	Dimension (a) X pitch mm	Tightening torque	
			Common connection	
			N-m	Ft-lb
Coarse thread	10	M6 X 1.0	9,8 ± 0,5	7, 2±0,4
	12, 13	M8 X 1.25	22,6±1,1	16,6±0,8
	14, 17	M10 X 1.5	47,1±2,4	34, 7 ± 1,7
	17,19	M12 X 1.75	83,4±4,1	61,5±3,0
	19, 22	M14 X 2,0	134,4±6,7	99,1±4,9
	22, 24	M16 X 2.0	207,9±10,4	153, 3 ± 7, 7
	27, 30	M20 X 2, 5	410,9±20,5	303,1 ± 15, 1
Fine thread	12, 13	M8 X 1.0	24,5±1,2	18,1±0,9
	14, 17	M10 X 1.25	50±2, 5	36,9±1,8
	17, 19	M12 X 1.5	87,3±4,3	64,4 ± 3, 2
	19, 22	M14 X 1.5	135, 3±6,8	99,8±5,0
	22, 24	M16 X 1.5	220,6±11	162,7 ± 8, 1
	27, 30	M20 X 1.5	452, 1 ±22,6	333,4 ± 16, 6

Critical Safety Parts

To operate the machine safely, please fulfill the periodical checking and maintenances. The following critical safety parts shall be replaced periodically to improve safety. These parts can cause serious injuries or fire accident if they are damaged.

List of Critical Safety Parts

Vehicle body		Periodically replaced critical safety part	Replacement period
Fuel system		Fuel pipes	Every 2 years
		Packing on fuel tank cover	
Heater		Heater hoses	
Cooling system		Rubber hoses	
Hydraulic system	Main machine	Hydraulic pipe (Pump outlet)	
		Hydraulic pipe (Pump oil suction port)	
		Hydraulic pipe (Slewing motor)	
		Hydraulic pipe (Traveling motor)	
	Working device	Hydraulic pipe (Boom cylinder pipeline)	
		Hydraulic pipe (Bucket arm cylinder pipeline)	
		Hydraulic pipe (Bucket cylinder pipeline)	
		Hydraulic pipe (Swing cylinder)	
		Hydraulic pipe (Bulldozing blade cylinder)	
		Hydraulic pipe (Span cylinder)	
		Hydraulic pipe (Pilot valve)	
		Hydraulic pipe (Auxiliary pipeline)	
		Seat Belt	Every 3 years
		Antiskid plate	

The materials of the above-mentioned critical safety parts will deteriorate along with time to cause wear or deteriorated performance. It's difficult to determine the deterioration extent during periodical checking. Therefore, such parts shall be replaced with new ones to guarantee stable performance, even if such parts are still working well. Please be noted that, regardless of the replacement schedule, any part with wear symptom must be replaced immediately. Upon

detection of any deformed or cracked pipe clamp, immediately replace it together with hose. Please consult with your sales or service dealer for the replacement of safety parts. Except the critical safety parts, check and tighten the hydraulic pipes and when necessary, replace. During the replacement of hydraulic pipes, replace the O-ring and seal ring as well. Check the fuel and hydraulic pipes as per the schedule specified by the following table

Checking type	Checking item
Daily routine checking	Leakage of hydraulic or fuel pipe connector Damage of cab or shelter - Replace *
Monthly checking	Leakage of hydraulic or fuel pipe connector Damage (Cracking, wear, and tear) of hydraulic or fuel pipe
Yearly checking	Leakage of hydraulic or fuel pipe connector Aging, distortion, and damage (Cracking, wear, and tear) of hydraulic or fuel pipe and/or status of hose in contact with other machine parts

Maintenance List

Checking and maintenance item	Date Completed
Walk-Around Checking	
Opening of engine hood and machine hood for checking	
Walk-around checking of machine	
Checking in driver seat	
Daily routine checking (Every 10h)	
Checking and adding of coolant	
Checking and adding of engine oil	
Checking of Fuel-Water Separator	
Checking of fuel level	
Checking of hydraulic oil tank oil level and adding of oil	
Lubrication of Working Device	
After first 20h (For new machine only)	
Checking and adjustment of fan belt	
Replacement of hydraulic oil return filter	
Every 50h	
Checking and adjustment of track tension	
Lubrication of slewing bearing	
Lubrication of slewing motor gear	
Water drainage from fuel tank	
Checking of battery electrolyte level and adding of electrolyte	
Every 100h	
Cleaning of water separator	
After first 250h (For new machine only)	
Replacement of traveling motor gear oil *	
Every 250h	
Checking and adjustment of fan belt	
Replacement of engine oil and filter	
Cleaning of air filter	
Checking of accelerator control system	
Cleaning of radiator fins and oil cooler fins	
Replacement of fuel filter	
Cleaning of air filter	

*: If the traveling time accounts for a high ratio of the total operating time, replace the gear oil ahead of the specified periods.

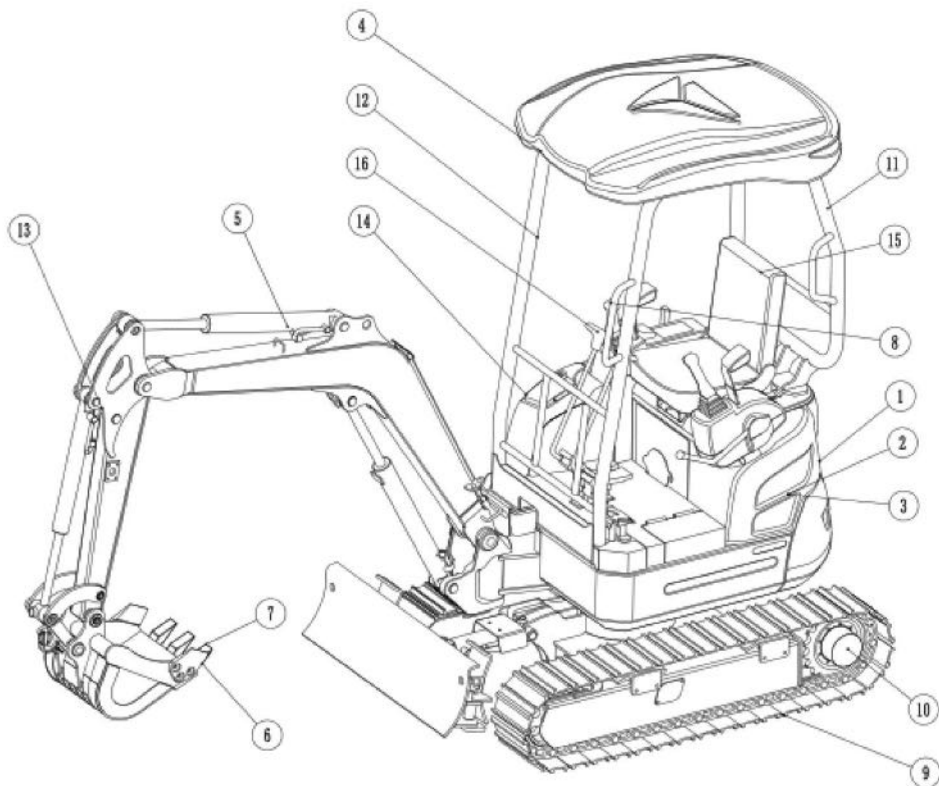

Walk-Around Checking

Fulfill the following checking before the first start of engine each day.

Before operations, fulfill the walk-around checking and when necessary, repair immediately.

Before operations within the machine, please securely fix the engine hood or machine hood.

Keep the engine hood and machine hood closed under windy weather or while parking the machine on a slope.

Opening of engine hood and machine hood for checking

Check for presence of branches, leaves, oil, and other inflammables around the engine and battery.

Check for presence of lubricating oil and coolant leakages around the engine.

Check hydraulic oil pipes, hydraulic devices, hoses, and connectors for oil leakage.
Walk-around checking of machine
Check lamps for presence of dusts and damages and check lamp bulbs for burnout.
Check hydraulic accessories and hoses for damage.
Check bucket, bucket teeth, and side teeth for wear, damage, and looseness.
Check hook, anti-slip stop block, and hook seat on bucket for presence of damage. (Optional)
Check handrails, footplates, and anti-slip surfaces for damage and check for any loose bolt.
Check tracks and track shoes for presence of slip, check track carrier rollers, idling device, and sprocket for presence of damage and wear, and check for loose bolt.
Check traveling motor for oil leakage.
Check shelter and guard plates for damage and check for loose nuts and bolts.
Check exterior and interior rearview mirrors for contamination and damage and when necessary, adjust.
Check labels for presence of dusts and damage.
Checking in Driver Seat
Check seat and seat belt for presence of dust and damage.
Check driver seat for presence of dust, oil dirt, and other inflammables.
Check monitor, electric devices, and switches for oil dirt, dust, and damage.

Daily routine checking (Every 10h)

Fulfill the following checking before the first start of engine each day.

Before operations, fulfill the daily routine checking and when necessary, repair immediately.

**Before operations within the machine, please securely fix the engine hood or machine hood.
Keep the engine hood and machine hood closed under windy weather or while parking the machine on a slope.**

Checking and adding of coolant Do not disassemble the radiator cap or drainage plug when the coolant is hot. Stop the engine, wait for the engine and radiator to cool down, and then slowly loosen and take out the radiator cap and drainage plug. **While handling the coolant (antifreeze), ensure to wear goggles and gloves. In event of splashing of coolant (antifreeze) into your eyes or onto your skin, clean by clean water immediately.**

Checking:

Open the engine hood.

Check the coolant level in the water tank (1). The coolant level shall be within upper limit (H) and lower limit (L). If below the lower limit (L), add coolant.

Adding:

Take out the cap (2) of water tank (1).

Add coolant, till the coolant level reaches upper limit (H) of water tank (1).

Upon detection of empty water tank (1) during checking, check for presence of water leakage and then check water level of radiator (3). When necessary, add water to the radiator (3) and then add water to the water tank (1).

Install the cap (2).

Note: Add clean water (soft water) only to compensate the lost coolant due to evaporation. Add the coolant (antifreeze) and clean water (soft water) of specified mixing ratio only to compensate the lost coolant due to leakage.

Checking and adding of engine oil

Please stop the engine and wait for the machine to cool down before maintenance. Checking

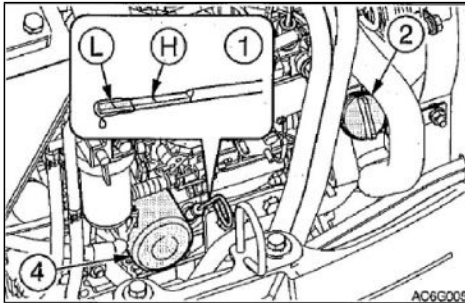

Checking:

Open the engine hood.

Withdraw the engine oil dipstick (1) and wipe it dry by a rag.

Insert the oil dipstick (1) to the end and then withdraw again.

Check the oil on the oil dipstick (1). The oil level shall be within upper limit (H) and lower limit (L). If below the lower limit (L), add oil.

Adding:

Take out the oil filler cap (2).

Add oil till the oil level is within upper limit (H)

and lower limit (L) of oil dipstick (1). Both excessive and insufficient oil levels will cause malfunction.

Tighten the oil filler cap (2).

Start the engine, run at low idling speed for 5min, and then stop the engine.

Check the oil level after approximately 10min.

Checking of fuel level

Do not smoke or use open fire while handling fuel or performing the operations of fuel system.

Do not disassemble the fuel tank cap or refuel while the engine is running or is not cooled down.

Do not splash fuel to any high temperature surface of machine.

Refuel the fuel tank in a well-ventilated place.

Any overflowed fuel shall be wiped away immediately.

Do not top up the fuel tank. Leave an expansion space for the fuel.

Tighten the fuel tank cap securely.

Use correct fuel grade based on the season.



Check the fuel level by fuel gauge (1).
 F: Full tank. E: Empty tank.
 If the fuel level is low, open the fuel tank cap.
 Checking of Fuel-Water Separator

Checking of Fuel-Water Separator (1).



Open the engine hood.
 If the red indicator ring (6) submerges to the bottom, there is no mixture of water.
 If the red indicator ring (6) floats, the water reaches the ring level.
 Drain water and clean.
 Checking of hydraulic oil tank oil level and adding of oil
 Warning

Disassembling cap or filter or disconnecting pipeline before the pressure relief of hydraulic system may result in out-spray of hydraulic oil. Slowly loosen the ventilation plug to relieve the internal pressure of tank.

Checking

The oil level varies along with the oil temperature. Maintain the machine and check the fuel status by the posture shown in the diagram below.

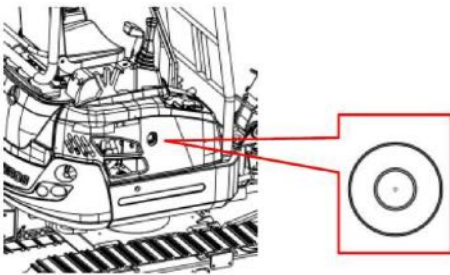

Start the engine and run at low speed.
 Fully extend the track width.
 Fully retract the cylinders (Bucket arm and bucket cylinders) and lower the bucket onto the ground.
 Lower the bulldozing blade and then stop the engine.
 Check the oil level by level gauge (1).
 When the oil temperature is approximately 20°C:

The oil level shall be within upper limit (H) and lower limit (L).
 If below the lower limit, add oil.
 When the oil temperature is approximately 50~80°C:
 The oil level shall be slightly lower than upper limit.

Adding

Important: While adding oil, the oil level shall not be above the upper limit (H). Otherwise, it will damage the hydraulic circuit or cause oil spray. If the oil level is too high due to carelessness, stop the engine, wait for the hydraulic oil to cool down, and drain the excessive oil from oil drainage port.

Important: Do not forget applying pressure to the hydraulic oil tank, in order to prevent the damage of pump due to air inhalation. (If no ventilator is installed.)

Open the engine hood.

Slowly loosen the bleeding plug (2) to relieve the internal pressure and then take out the plug.

Add hydraulic oil, till the oil level is in the middle of level gauge (1).

Pressurize the hydraulic oil tank as shown in diagram below.

Note: For machine with ventilator, no pressurization is required.

Pressurization of Hydraulic Oil Tank

Start the engine and run at low speed.

Disassemble the bleeding plug (2) and set the safety lock handle to unlocking position. swing, and span cylinders.

Stop the engine and lift up the safety lock handle to locking position.

Tighten the bleeding plug (2) and then pressurize by retracting cylinders.

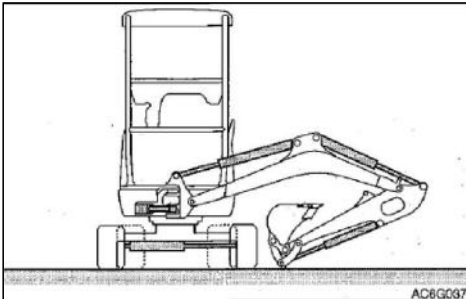

Lubrication of Working Device

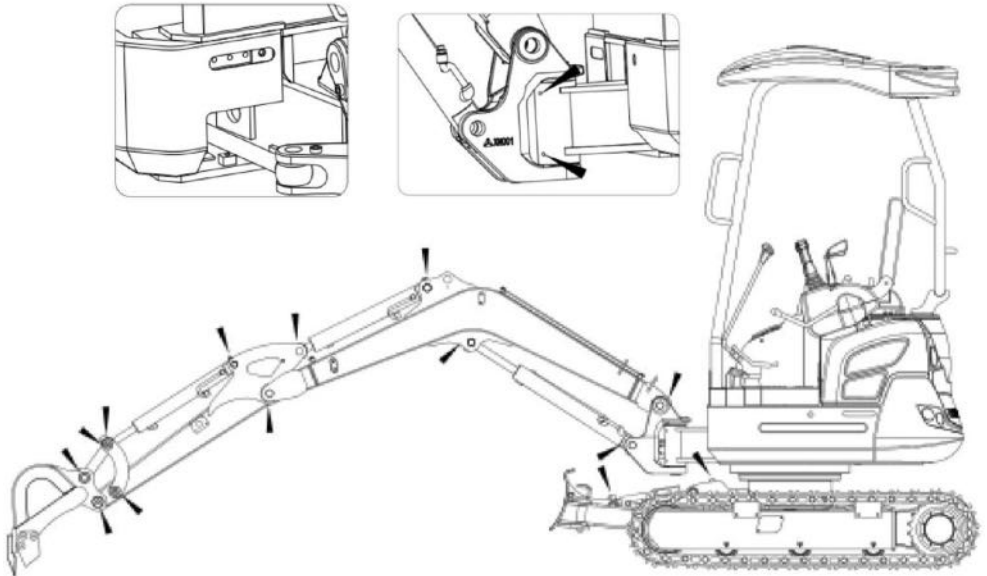

Maintain the machine under the status shown in above diagram, lower the working device to the ground, and then stop the engine.

Lubricate the grease fitting by a grease gun.

Wipe away excessive grease.

Records

After first 50h (For new machine only) Checking and adjustment of fan belt

Please stop the engine and wait for the machine to cool down before maintenance.

The engine, exhaust pipe, radiator, hydraulic pipes, sliding parts, and many other machine parts are really hot when the engine is just stopped. Touching such parts can cause scalding.

Important: A loose belt can cause poor charging of battery, overheating of engine, or earlier wear of belt. The over-tight belt will damage the water pump or bearing and alternator drive belt.

Important: Keep the belts away from all greases.



Checking

Open left side gate of machine.

Check the tension (Approximately 98N) based on the centers of fan pulley (1) and alternator pulley (2).

Check the fan belt (3). Upon detection of any of following conditions, replace.

Rupture or cracking.

The belt is worn to touch the bottom of pulley V-grooves.

The belt is stretched loosely and is non-adjustable.

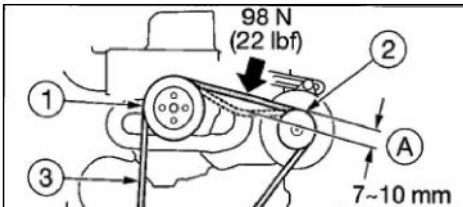

Adjustment

Loosen bolt (5) and lock nut (4).

Rotate the adjustment bolt (6) to move the alternator (7) and adjust the tension of fan belt (1).

Increase tension: Clockwise Reduce tension:

Counter-clockwise

Tighten bolt (5) and lock nut (4).

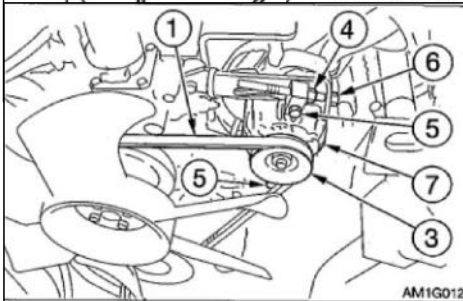

Note: After the replacement with new belt, run the engine at low idling speed for approximately 3~5min to run in new belt and then adjust the tension.

Replacement of hydraulic oil return filter

Slowly loosen the bleeding plug to relieve the pressure of oil tank.

While disassembling connector or plug or disconnecting hose, stand on one side, loosen slowly to gradually relieve internal pressure, and then take out.

Warning

Please stop the engine and wait for the machine to cool down before maintenance.

The engine, hydraulic system, and many other parts are hot after operation. Touching such parts can cause scalding. The hydraulic oil is also under high temperature and high pressure. Take caution not to touch the hydraulic oil while loosening engine hood or connector. Operating the machine under such condition can cause out-spray of hot oil which may result in scalding and injuries.

Disassemble the right covering part.

Slowly loosen the bleeding plug (1) to relieve the internal pressure and then take out the plug.

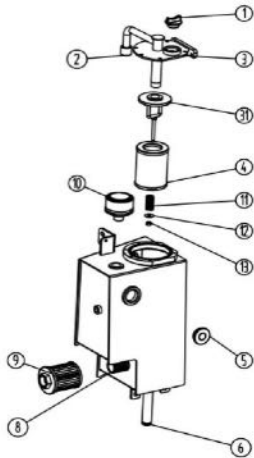

Loosen the hose band and take out the hose (2) from the flange (3).

Loosen the bolt and take out the flange (3).

Take out the oil return filter (4).

Install new oil return filter.

Reinstall flange (3) and hose (2).

Check the level-by-level gauge (5). If the level is too low, add oil.

Note: For machine with ventilator, no pressurization is required.

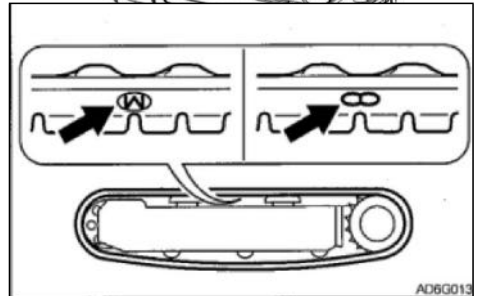
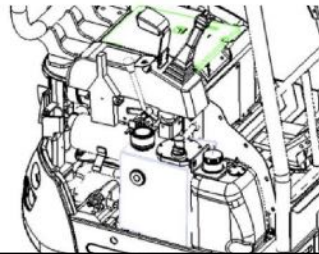

Every 50h

Checking and Adjustment of Front Toe.

For rubber tracks, adjust the marking "M" at the joints to the top center of track frame.

Lift the machine body by working device.

Slowly operate the joysticks.

Check the track tension.

Check the clearance (A or B) between the frame bottom face and track top face in the middle of track frame. The clearance (A or B) shall be within following range:

rubber tracks 59~64mm

Steel tracks 95 to 110mm

Adjustment Increasing of Tension

Remove the cover plate.

Slowly loosen (by one turn) the grease relief valve (2) by a wrench to drain the grease. If it's difficult to drain the grease, drive the machine back and forth.

Tighten the grease relief valve (2).

Tightening torque: 177 N·M

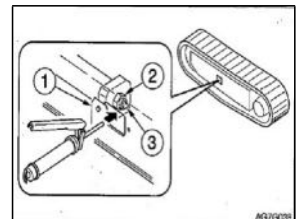

Lubricate the slewing bearing

Do not slew during lubrication. Otherwise, you may be entangled into the machine.

Take out the cover plate (1).

Use a grease gun to inject lubricating grease via the grease fitting (3) of grease

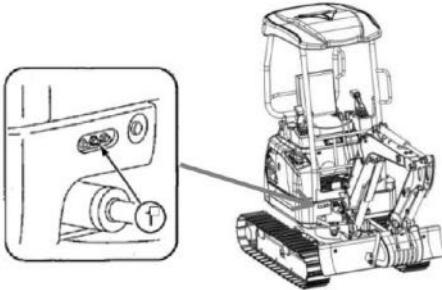

Stop the machine as per the posture shown in above diagram and stop the engine.

Lubricate the grease fitting (1) by a grease gun.

Start the engine, lift the bucket, and rotate clockwise for 90°.

Lower the bucket onto the ground and then stop the engine.

Repeat above steps 2~4 for 3 times.

Wipe away the grease drained from the slewing bearing and grease pipe.

Lubrication of slewing motor gear

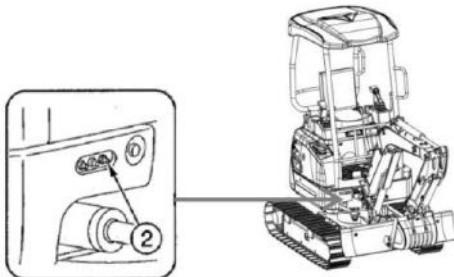

Lubricate the grease fitting (2) by a grease gun.

Wipe away excessive grease.

Water drainage from fuel tank

Tighten the fuel tank cap securely.

Use correct fuel grade based on the season.

Take out the fuel tank cap (2).

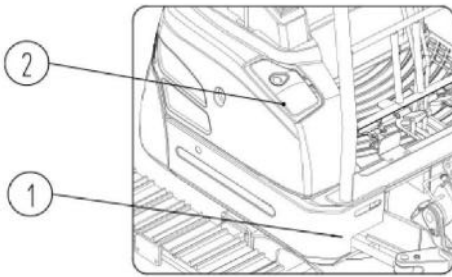

Place a box beneath the water drainage plug (1).

Loosen the water drainage plug (1) to fully drain the water and the deposits from the tank.

Tighten the water drainage plug (1).

Tighten and lock the fuel tank cap (2).

Bleed the air.

Air Bleeding of Fuel System

Note: The air content in the fuel system will cause start failure or start difficulty of engine. Bleed the air by same procedure described above when the fuel tank is empty.

Checking of battery electrolyte level and adding of electrolyte

The battery can generate flammable hydrogen which can cause explosion. Keep away from fire sources including open fire, spark, and ignited cigarette.

Do not clean by a dry cloth, otherwise it can cause electrostatic accumulation and combustion or explosion.

Warning

During the operations of battery, wear goggles and protective clothing.

Do not fill the distilled water till the level is above the upper limit. Otherwise, the electrolyte will leak out. The contact with such electrolyte can harm your skin or corrode the machine parts.

The battery contains sulfur acid. The accidental touch will harm your eyes or skin.

In event of accidental contact with eyes, immediately flush by clean water and quickly seek for medical treatment.

In event of accidental swallowing, immediately seek for medical treatment.

If the sulfur acid comes into contact with your skin or clothing, immediately flush with water.

Check the fluid level. The fluid level must be between upper limit (H) and lower limit (L). If not, add distilled water till the fluid level reaches upper limit (H).

Check terminals for looseness and contamination.

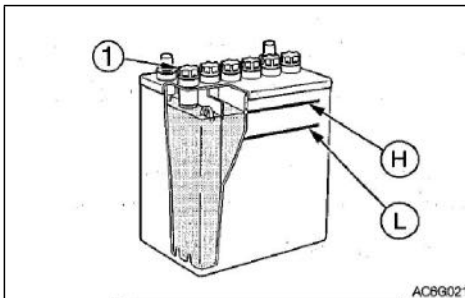

If the adding of distilled water is required, add water before start of operations, in order to prevent freezing.

Take out the cap (1) and add distilled water till the upper limit (H) is reached.

Clean the ventilation port on the cap and securely tighten the cap (1).

Every 100h

Cleaning of water separator

Open the side cap.

Close valve (2).

Loosen the ring (3) and then take out and clean the box (4), filter element (5), indicator ring (6), and spring (7).

Check the O-ring and filter element (5).

Upon detection of any scratch or other unevenness, replace.

Install the indicator ring (6), spring (7), filter element (5), and box (4) and then tighten the ring (3).

Open valve (2) to vacuumize.

After first 250h (For new machine only)

Replacement of traveling motor gear oil

Please stop the engine and wait for the machine to cool down before maintenance.

The traveling motor is hot after operation.

Touching it can cause scalding.

The gear oil is also high temperature and under high pressure after operation. Take caution while loosening the screw plug. Operating the machine in such case will cause scalding and injuries.

The high pressure in the traveling motor reducer gearbox will cause fly-out of gear oil or screw plug. Slowly loosen the screw plug to relieve the pressure.

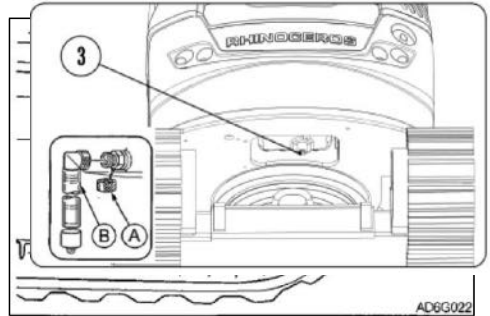

Adjust the position of traveling motor to place the screw plug (1) at bottommost position.

Place a tray beneath the screw plug (1).

Take out the screw plugs (1) and (2) and drain the oil.

Re-wrap the screw plug with new seal ring.

Tighten the screw plug (1).

Add oil through screw plug hole (2), till the oil flows out from screw plug hole (2).

Tighten the screw plug (2).

Important: If applicable, follow the attachment manufacturer's procedure to bleed the air.

Every 250-hour

Checking and adjustment of fan belt

Replacement of engine oil and filter

Please stop the engine and wait for the machine to cool down before maintenance.

The engine, exhaust pipe, radiator, hydraulic pipes, sliding parts, and many other machine parts are hot after operation. Touching such parts can cause scalding.

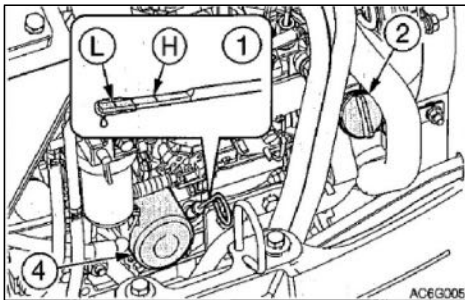

Open the engine hood and take out the oil filler port (2).

Place a tray beneath the oil drainage plug (2) to collect the drained oil.

Take out the cap (A), install the connecting pipe (B), and drain the oil. (The engine oil flows out after the tightening of bolt).

Take out the connector (B) and install the cap (A).

Important: Check the used oil for presence of metal particles. Upon detection of numerous

metal particles, please consult with your sales or service dealer.

Rotate the filter (4) counterclockwise by a filter wrench to take it out.

Clean the mounting surfaces of filter housing.

Apply a thin film of oil to the washer of new filter.

Manually install new filter.

After the washer of filter comes into contact with the mounting surface, tighten the filter further for one turn (by oil filter wrench). (Tightening torque by oil filter wrench: 19.6~23.5N.m).

Add lubricating oil till the oil level is within upper limit (H) and lower limit (L) of oil dipstick (1).

Both excessive and insufficient oil levels can cause malfunctions.

Tighten the filler cap.

Start the engine and run at low idling speed for 5min.

Check the oil level after approximately 10min.

Cleaning of Air Filter

Please stop the engine and wait for the machine to cool down before maintenance.

While using compressed air, please wear necessary protection appliances, including goggles and filtration mask, as the metal fragments and other objects will splash to cause accidents of serious harm.

Important: Take caution not to scratch the filter element. Do not use any damaged filter element.

Important: During operations under dusty environment, please daily fulfill the checking and maintenances for the machine. Important: Ensure to steadily install the filter element and dust cover. Otherwise, the ingress of dust into the cylinders will damage the engine.

Open the engine hood.

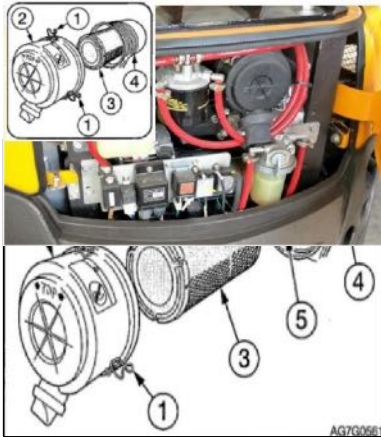

Loosen the clamp (1) and take out the dust collector (2).

Clean the inside of dust collector (2).

Take out the primary filter element (3).

Cover the inlet and outlet on the back of body (4) by cloth or tape to guard against ingress of dusts.

<If the secondary filter element is installed>

To prevent the ingress of dusts into engine, do not take out the secondary filter element (5).

Clean the inside of housing (4).

Checking of accelerator control system

The accelerator joystick and the speed regulator on the engine side are connected by wiring. Check the wires at their fixing positions for presence of stretching and looseness.

If the wires at their fixing positions are stretched or loose, there probably has a malfunction.

The replacement and adjustment of wires require experiences. Please ask your sales or service dealer for operations.

Cleaning of radiator fins and oil cooler fins

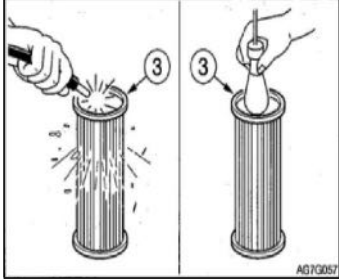

Clean primary filter element (3) by dry compressed air (294~490kPa). Firstly, blow along the wrinkles from the inside of filter element. Then blow from outside and finally blow from inside.

Illuminate the inside of primary filter element (3) by a lamp to check. Upon detection of any pinhole or dirt, replace.

Remove the cloth or tape used in step 5.

Install the primary filter element (3).

Install the dust collector (2) by facing upward the “↑TOP↑” and then secure it by clamp (1).

Important: Take caution not to damage the radiator fins during cleaning.

Blow compressed air towards the radiator fins to remove the adhered dusts and mud.

While using compressed air, please wear necessary protection appliances, including goggles and filtration mask, as the metal fragments and other objects will splash to cause accidents of serious harm. While using compressed air or high pressure water, ensure that the pressure is no higher than 200kPa and keep the air nozzle from the radiator for a sufficient spacing.

Important: While cleaning by water, please cover the electric system against water ingress.

Important: Important: During the operations under dusty environment, please daily fulfill the checking and maintenances for the machine.

Replacement of Fuel Filter



Open the engine hood.

Rotate the filter (1) counterclockwise by a filter wrench to take it out.

Clean the mounting surfaces of filter housing.

Apply a thin film of fuel to the washer of new filter housing.

Manually install new filter.

After the filter washer comes into contact with the mounting surface, tighten the filter further for one turn. (Tightening torque by filter wrench: 20~24N.m).
Bleed the air.

Every 500-hour

Replacement of Hydraulic Oil Tank Return Filter
Replacement of Water Separator Filter

Opening of Side Gate

Close valve (2).

Loosen the ring (3) and take out the box (4).

Take out the spring (7) and indicator ring (6) from the box (4).

Clean the box (4).

Check the O-ring. Upon detection of any scratch or other unevenness, replace.

Replace with new filter element.

Install the indicator ring (6) and spring (7) to the box (4).

Install the box (4) to the bracket and manually tighten the ring (3).

Open valve (2) to vacuumize.

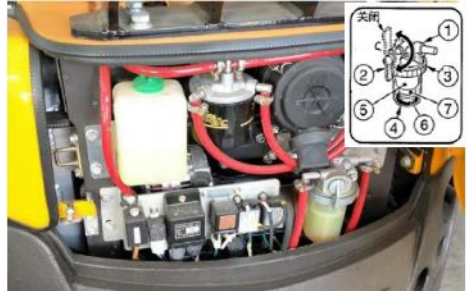

Every 1000h

Replacement of traveling motor gear oil

Warning: Please stop the engine and wait for the machine to cool down before maintenance.

Important: Do not use a wrinkled filter element or a filter element with damaged washer or seal ring.

Important: Ensure to steadily install the filter element and dust cover. Otherwise, the ingress of dusts into the cylinders will damage the engine.

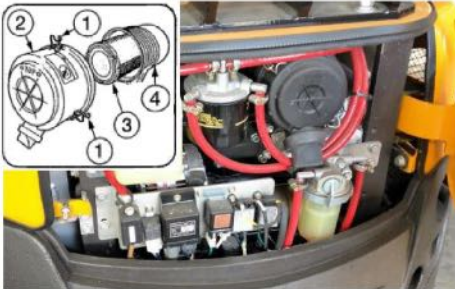

Take out the primary filter element (3).

Cover the inlet and outlet on the back of body (4) by cloth or tape to guard against ingress of dusts.

Clean the inside of housing (4).

Remove the cloth or tape used in step 5.

Replace the air filter element

Open the engine hood.

Loosen the clamp (1) and take out the dust collector (2).

Clean the inside of dust collector (2).

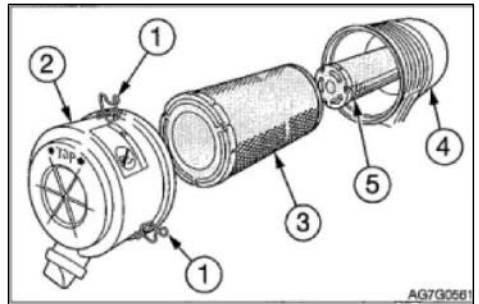

Install new filter element.

Install the dust collector (2) by facing upward the “↑TOP↑” and then secure it by clamp (1).

Checking and Adjustment of Engine Valve Clearance

These operations require experiences. Please ask your sales or service dealer for operations.

Cleaning of Engine Cooling System

Please stop the engine and wait for the machine to cool down before maintenance.

The engine coolant is also under high temperature and high pressure after operation. Take special caution while loosening the cap or plug. Operating the machine in such case may cause scalding and injuries by splashing high temperature coolant.

If the maintenance requires the running of engine, assign two operators for teamwork and keep contact with each other. One operator must sit in the driver seat to get ready to stop the engine immediately when necessary. This operator must pay special attention not to touch any joystick or pedal, unless it's absolutely necessary. The other operator for the maintenance must keep the body and clothing away from motion parts of machine. While the engine is running, it's really dangerous standing behind the machine, as the machine probably moves suddenly. While the engine is running, never stand behind the machine.

Do not disassemble the radiator cap or drainage plug when the coolant is hot.

Stop the engine, wait for the engine and radiator to cool down, and then slowly loosen and take out the radiator cap and drainage plug.

During cleaning, if the coolant temperature is low, the thermostat will be closed, and the coolant will not flow within the radiator. Before cleaning, heat up the coolant to at least 90°C.

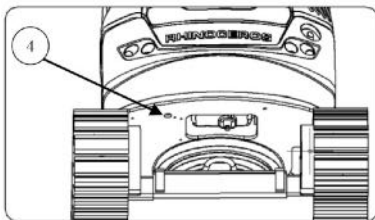

Open the engine hood.

Slowly loosen the radiator cap (3) to relieve the internal pressure and then take out the cap.

Place a tray beneath the water drainage plug (4) to collect the used coolant and then loosen the water drainage plug (4) to drain the coolant.

Tighten the water drainage plug (4).

Add running water through the water filler port into the radiator, till the water level reaches the top of filler port. Add the water slowly and easily to prevent the ingress of air into radiator.

Install the radiator cap (3).

Start the engine and run the engine at a speed slightly higher than the low idling speed. Heat up the water temperature to at least 90°C, open the thermostat, and then run the engine for approximately 10min.

Stop the engine, wait for the coolant to cool down, and then take out the drainage plug (4) to drain the water.

After water drainage, clean the cooling system by detergent. Use the detergent as per the attached operation instructions of the detergent.

Repeat steps 4~8 to clean the cooling system.

Tighten the water drainage plug (4).

Add new coolant (Mixture of antifreeze and running water) through filler port to the radiator, till the radiator is full. Add the coolant slowly and easily.

Install the radiator cap (3).

Warm up the engine. Use instruments to check the cooling system for presence of abnormality. Increase the water temperature to at least 90°C. Then, open the thermostat and run the engine for approximately 10min.

Stop the engine, wait for the coolant to cool down, and then check the coolant level in the radiator.

Install the radiator cap (3).

Clean the inside of water tank (1) and add coolant, till the water level reaches upper limit (H).

If the coolant is replaced, re-check the coolant level after the operations of machine.

Once the machine starts operations, the

coolant is distributed to the whole system so that the coolant level drops.

Add the coolant to compensate the consumed coolant.

Every 1500-hour

Checking and Cleaning of Engine Fuel Injector Nozzles

These operations require experience. Please ask your sales or service dealer.

Checking of Crankcase Ventilation Hole System

These operations require experience. Please ask your sales or service dealer.

Every 2000h

Connection of Engine Valve Seats

These operations require experience. Please ask your sales or service dealer.

Replacement of Hydraulic Oil and Cleaning of Oil Suction Filter Screen

Warning: Please stop the engine and wait for the machine to cool down before maintenance.

Adjust the machine to the hydraulic oil level checking status.

Lift up the safety lock handle to the locking position.
 Open the engine hood.
 Slowly loosen the bleeding plug (1) to relieve the internal pressure of hydraulic oil tank.

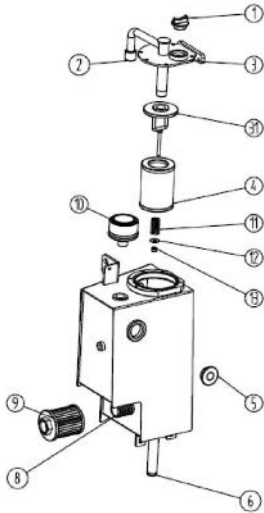

Loosen the hose band and take out the hose (2) from the flange (3).

Loosen the bolt and take out the flange (3).

Take out the oil return filter (4).

Place a tray beneath the oil drainage plug (6) to collect the drained oil.

Loosen the water drainage plug (6) to fully drain the hydraulic oil.

Loosen the hose and take out the hose (7).

Loosen the bolt and take out the flange (8).

Take out the oil suction filter element (9) and clean.

Clean the inner side of hydraulic oil tank.

Replace ventilator (10) (If installed).

Install the oil suction filter screen (9) to the flange (8).

Reinstall the flange (8) and hose (7) to original positions.

Install new oil return filter to the flange (3).

Reinstall the flange (3) to original position.

Tighten the water drainage plug (6).

Add hydraulic oil through plug hole (1) till the oil level is between upper limit (H) and lower limit (L) of level gauge (5).

Pressurize the hydraulic oil tank. (If no ventilator is installed)

For machine with ventilator, no pressurization is required.

Tighten the screw plug (1).

Bleed the air from the hydraulic oil circuit

Adjust the machine to hydraulic oil level checking status, wait for the oil to cool down, and then check the oil level.

Air Bleeding

Important: After the replacement of hydraulic oil, bleed the air from hydraulic pipelines and hydraulic devices. Otherwise, the hydraulic devices may be damaged.

Cylinders

Start the engine and run at low idling speed for 10min.

Keep the engine running at low idling speed, extend and retract all cylinders for 4~5 times, but take caution not to telescope any cylinder to the end.

Run the engine at high speed, extend and retract all cylinders for 4~5 times, but take caution not to telescope any cylinder to the end.

Restore the engine to low idling speed, extend and retract all cylinders for 4~5 times, and always telescope to the end.

Replace bucket teeth (as necessary)

Replace the bucket teeth when the tooth sleeves are worn. Do not wait for the bucket to be damaged before replacement.

If the bucket teeth are worn to 140mm, replace.

Warning: Before maintenance or repairs beneath the machine, lower all movable working devices onto the ground or lowest position.

During the repairs and replacements of bucket teeth or side teeth, to prevent the accidental movement of machine, securely fix the working device.

During the use of hammer, the pins and the metal fragments may fly out. It may cause serious personal harm.

While hammering hard metal parts such as tooth pins, bucket teeth, side teeth, and bearings, please wear protective articles including goggles and gloves.

While hammering tooth pins and bucket teeth, ensure there is no person in surrounding area.

During operations, non-authorized personnel are prohibited to access the working zone.

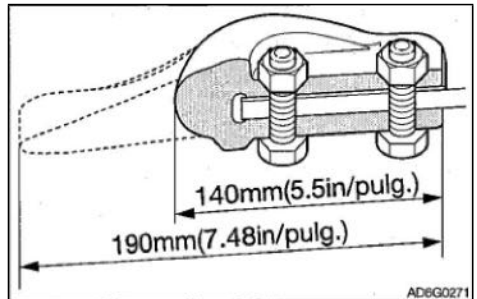

Disassembling

Clean the bucket and park the machine on a level, firm, and safe ground.

Place level the bottom face of bucket and cushion it with cushion block to ease the disassembling of bolts (1).

Withdraw the starter key and check bucket for steady placement.

Disassemble the bolts (1).

Replace bucket teeth (2) and shims (3).

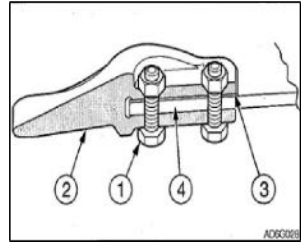

Installation

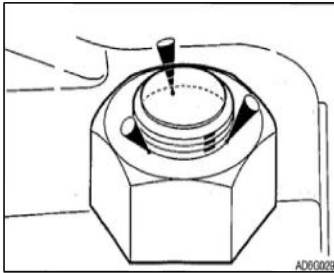

Clean the area for installation of bucket tooth. If there is any soil or mud in this area, the bucket tooth and tooth sleeve probably can't be inserted completely.

Place the bucket tooth into the bucket.

If the bucket tooth is insecure, please insert a shim to reduce the gap.

Insert the bolt from outer side of bucket and tighten by nut. Tightening torque: 102 N.m.

Rivet the bolt by a press or perform three-point welding at the threaded portion (Nut end).

Replacement of Bucket

Warning: Before maintenance or repairs beneath the machine, lower all working devices onto the ground or lowest position.

If the maintenance requires the running of engine, assign two operators for teamwork and keep contact with each other.

One operator must sit in the driver seat to get ready to stop the engine immediately when necessary. This operator must pay special attention not to touch any joystick or pedal, unless it's absolutely necessary.

The other operator for the maintenance must keep the body and clothing away from motion parts of machine.

During the use of hammer, the pins and the metal fragments may fly out. It may cause serious personal harm.

While hammering hard metal parts such as tooth pins, bucket teeth, side teeth, and bearings, please wear protective articles including goggles and gloves.

While hammering tooth pins and bucket teeth, ensure there is no person in surrounding area.

While aligning pinholes, always check by visual observation. Do not insert your finger into pinholes, otherwise your finger may be lost.

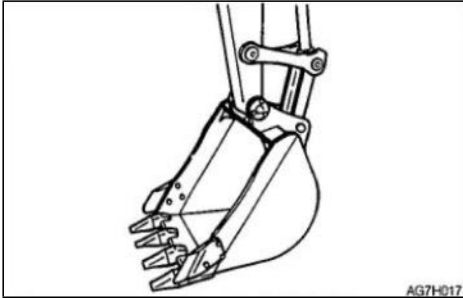

Disassembling

Disassemble the bucket. Check the pin seal ring (3). Upon detection of deformation or damage, replace.

Installation

Lower the bucket steadily onto the ground as shown in above diagram.

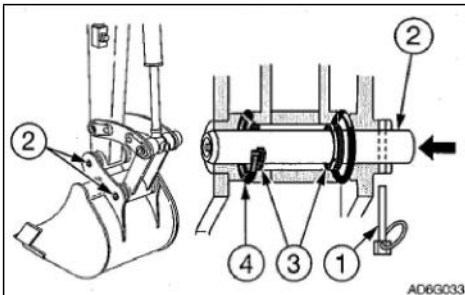

Note: While disassembling the tooth pin, adjust the bucket position in such manner that the bucket barely comes into contact with the ground. If the bucket is steadily on the ground, the resistance will be really high making it difficult to disassemble the tooth pin.

Place the safety lock handle to locking position and stop the engine.

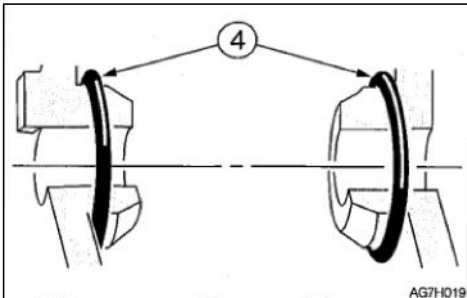

Place O-ring (4) onto the bucket, as shown in above diagram.

Unlock the ring of lock pin (1) and take out the lock pin (1). Knock the tooth pin (2) from the bucket by align the pinholes (A) on the bucket with pinholes on bucket arm (5) and install the tooth pins (2).

Operate the cylinders to align the pinholes (B) on the bucket with pinholes on connecting rod (6) and install the tooth pins (2).

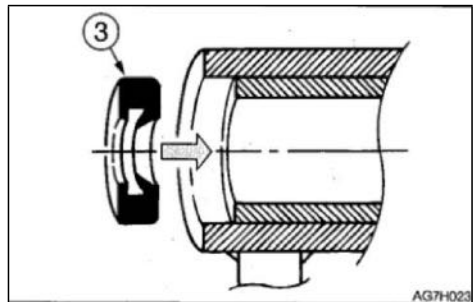
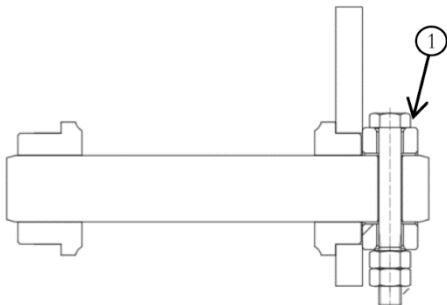

Align the anti-rotation holes, install the lock bolts (2), and install and tighten 2 nuts. Adjust the pin seal ring (3) to the orientation shown in above diagram. Use a small wood hammer to press in the pin seal ring lightly. Take caution not to damage the seal ring.

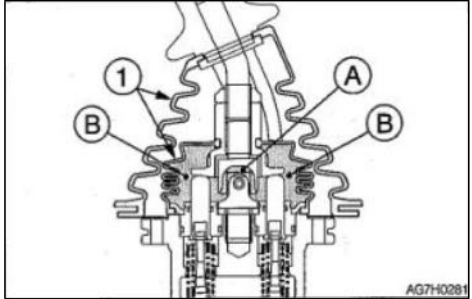
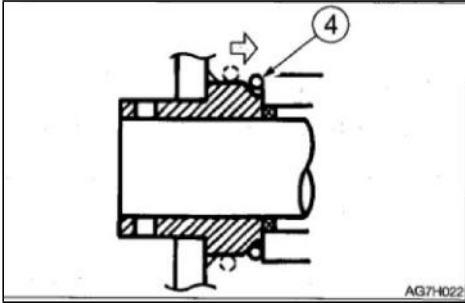

Lubrication of Joysticks and Pedals

Warning: Stop engine and remove key prior to maintenance
In event of inflexible operation of any joystick or pedal, please add oil for lubrication.

Joystick

Replacement of Pin Seal Rings
Take out the base part beneath the protective sleeve (1) and upturn it.
Wipe away the old grease.
Spray grease to points (A) and (B).
Slide the O-ring (4).
Place the protective sleeve (1) to original position.

Joystick, and Pedal

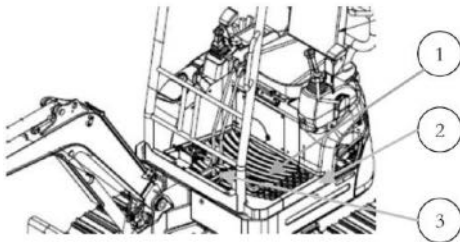

Take out the floor mat (1).
Loosen the bolts and take out the cap (2).
Take out the base part beneath the protective sleeve (3) and upturn it.
Wipe away excessive grease.
During installation, please operate in reverse sequence of the disassembling procedure.

Disassembling

Completely loosen the tension of rubber tracks.

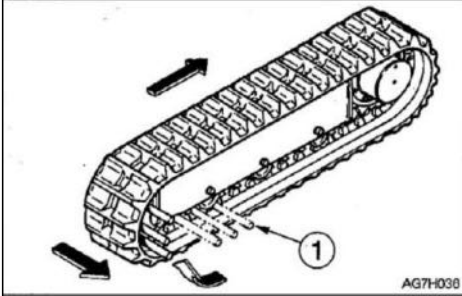

Lift the machine body by working device.

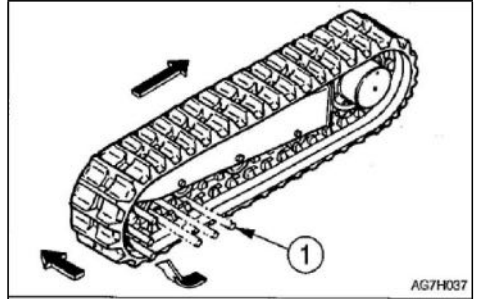

Place a steel tube (1) in the rubber track and rotate the sprocket slowly towards opposite direction.

Rotate the sprocket till the steel tube (1) closes to the tensioner and the rubber track is lifted off the tensioner and then stop the rotation of sprocket.

Laterally slide the rubber track to take out it from track frame. Take out the other rubber track by same procedure.

Installation

Lift the machine body by working device.

Place rubber track on the sprocket.

Place a steel tube (1) in the rubber track and rotate the sprocket slowly towards opposite direction.

Rotate the sprocket till the steel tube (1) closes to the tensioner and the rubber track is lifted off the tensioner and then stop the rotation of sprocket.

Slide inward the rubber track to install it onto the tensioner and then pull out the steel tube.

Check rubber track for secure installation on sprocket and tensioner.

Tension the rubber track to standard tension.

Install the other rubber track by same procedure.

Maintenances during Long-Time Parking

If it's necessary to park the machine for ≥ 30 days, please park the machine indoors. If it's necessary to park outdoors, please park the machine on a wood-paved level ground and cover the machine by water-proof cap to keep dry.

Clean the machine.

Check for oil/water leakage and cracking and check for any loose nut or bolt.
Refuel and replace hydraulic oil and lubricating oil.
To prevent rusting and freezing, replace the engine coolant with long-life coolant (LLC).

Lubricate the grease fitting by a grease gun.
Fully retract the bucket and bucket arm cylinders and lower the bucket and bulldozing blade onto the ground.
Apply anti-rusting oil to the hydraulic cylinders.
Disconnect the negative cable of battery and cover the battery to guard against freezing.
Do not operate the machine in an enclosed place with poor ventilation.

To prevent rusting, operate the machine once a month to circulate the oil throughout whole system.

Check the battery and when necessary, charge the battery. Please ask your sales or service dealer for charging.

Start of Machine after Parking

Important: If the above-mentioned "Parking procedure" is not followed during the long-time parking of machine, please consult with your sales or service dealer before restarting the machine.

Wipe away the lubricating oil from the piston rods of the hydraulic cylinders.
When necessary, add lubricating oil or grease.
Fulfill the daily checking.
Pre-lubricate the engine before start.
Crank the engine for 15s and notice to keep the fuel system closed to prevent start of engine.
Stop for 30s.
Repeat this procedure, till the engine is already cranked for 1min in total. This can enable the sufficient oil circulation throughout the lubrication system of engine.
Prepare the fuel system.
Start the engine. Idle the engine for approximately 15min and then:
Check for normal oil pressure.
Check for leakage of fuel, engine oil, and coolant and check indicator lamps and/or level gauge for normal functioning.
Avoid operating for a long time at minimum or maximum engine speed or operating the loaded residue within the first loading hour.

Troubleshooting

Symptoms other than Malfunctions

The following symptoms are not malfunctions.

With engine running at low speed, when the bucket arm reaches a nearly vertical position, its retraction speed will drop shortly.

With engine running at low speed, when the bucket teeth reach a nearly horizontal position, its movement speed will drop shortly.

A noise of slewing motor can be heard at the start and end of slewing.

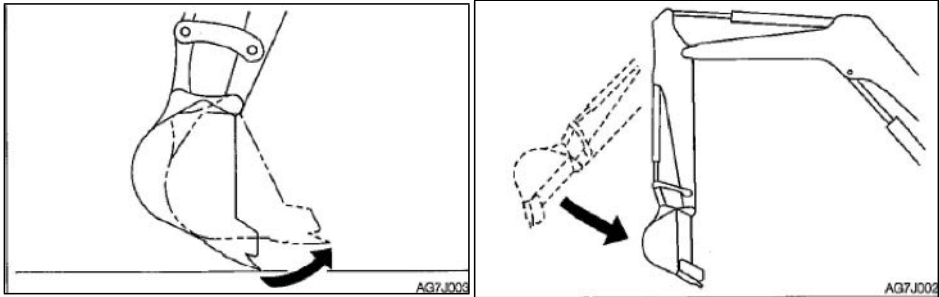

A noise of traveling motor can be heard when the machine stops suddenly during high-speed traveling.

A noise of control valve can be heard when the working device is subject to excessive external force or moves to the end of travel.

The operations of the machine are more difficult when an attachment heavier than the standard bucket arm or bucket is installed.

Engine Overheating

Warning: If the steam overflows from the engine, do not open the engine hood or machine hood. The steam or hot water may spray out to cause scalding.

Do not disassemble the radiator cap or drainage plug when the coolant is hot. Stop the engine, wait for the engine and radiator to cool down, and then slowly loosen the radiator cap to relieve the internal pressure.

Please stop the engine and wait for the machine to cool down before maintenance.

The following symptoms indicate overheating.



A warning tone is heard and the engine emergency warning lamp and the water temperature warning start to flash.

Steam overflowing from engine compartment.

Remedy procedure

Park the machine on a safe place.

Check whether the steam overflows from the closed engine hood or machine hood.

If the steam overflows from engine compartment, immediately stop the engine and contact your sales or service dealer for repair. If no steam overflows, run the engine at low idling speed to cool down the coolant.

When the LED of the water temperature gauge drops to green zone, stop the engine.

After the engine cools down, immediately take the following checking and remedy measures.

Loose fan belt

Low coolant level.

Water leakage- Repair.

Dirty radiator fins

Deposits in cooling system

If the malfunction still exists after the above-mentioned remedy procedures are taken, please contact your sales or service dealers for repairs.

No Battery Power

The following symptoms indicate no battery power.

No rotation of starter motor or start failure of engine.

Low volume of horn.

Remedy procedure

Start the engine by the booster battery on another machine (booster machine) and jumper cable.

Warning: to start the engine by jumper cable, ensure to connect the cable by correct procedure. The improper use of jumper cable will result in battery explosion or cable to start engine.

Important: The jumper cable and clamps in use shall be suitable to the battery capacity. Do not use any damaged or corroded jumper cable or clamp. Important: Ensure the same capacity for the battery on the rescue machine and the battery on malfunctioned machine.

Important: Ensure to connect the cable clamps securely.

Connection of Jumper Cable

Important: Place the starter keys of both rescue machine and malfunctioned machine to OFF.

The booster machine and the machine with depleted battery are prohibited for mutual contact. The positive (+) and negative (-) clamps of the jumper cable are prohibited for mutual contact.

During connection, firstly connect the jumper cable to positive (+) terminal. During disconnection, firstly disconnect the cable from negative (-) terminal.

Connect the last clamp of jumper cable to a point as far as possible from the battery. Connect a clamp of jumper cable (R) to the positive (+) pole of malfunctioned machine.

Connect the other jumper cable clamp (R) to the booster (+).

Connect the jumper cable clamp (B) to the charger (-).

Connect the other clamp of jumper cable (B) to the engine support of the malfunctioned machine. Connect the clamp to a point as far as possible from the battery.

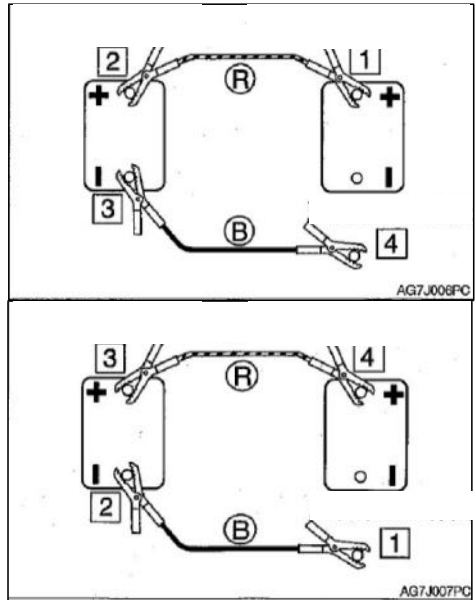

After Start of Engine

Check and ensure that the wire clamps are already connected securely to various terminals.

Start the engine of rescue machine and run it at high speed.

Start the engine of the malfunctioned machine.

Disconnection of Jumper Cable

After the successful start of the engine of malfunctioned machine, disconnect the jumper cable in reverse sequence of the connection procedure.

Disconnect the jumper cable (R) clamp from the charger (+).

Disconnect the jumper cable clamp (R) from the uncharged machine (+).

Disconnect the clamp of jumper cable (B) from the engine support of malfunctioned machine.

Disconnect the other jumper cable (B)

Burnout of Fuse

If a lamp fails to turn on or the electronic system fails to work, the fuse is probably burnt. Check the fuse.

Checking and Replacement of Fuses

Warning: If a fuse is burnt again shortly after replacement, the electronic system is probably malfunctioned. The improper repair may cause fire danger. If the consultation is required, please contact your sales or service dealer.

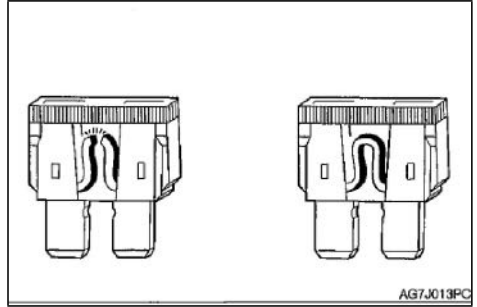

Rotate the starter key to OFF to stop the engine.

Open the access panel.

Open the fuse case cover (1).

Check fuses for burnout.

If a fuse is burnt, please replace with spare fuse of same specification.

Layout and protected circuits of fuses

Specification	Protected circuit
30A	Starter switch
10A	Power lamp
10A	Horn power supply
30A	Flameout power supply

Checking of Fuses

If the engine fails to start after the starter switch is rotated to ON, the filter cartridge fuse (1) is probably burnt. Open the access panel to check.

If the fuse is already burnt, please contact your sales or service dealer.

Note: The fuses are large fuses used in high current applications. Like common fuses, they play the role of fuses to protect the electric parts and wiring against the damages due to high current.

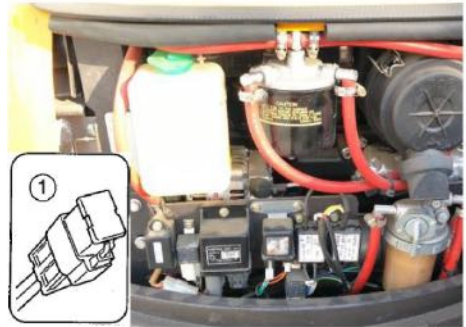

Restart after Refueling

Air Bleeding from Fuel System Importance: Do not rotate the engine by starter motor to prepare the fuel system. This may cause overheating of starter motor to damage coil, pinion, and/or ring gear.

Important: If the engine stops due to shortage of fuel, please add fuel, rotate the key to ON for 60s, and then rotate it to START position. Running the starter motor for a long time before the supply of sufficient fuel will cause start failure of starter.

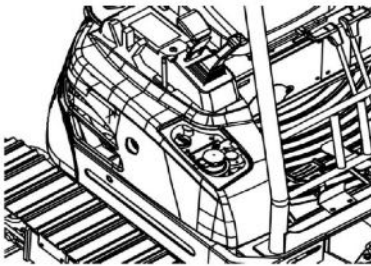

Add fuel.
Close

Open the valve (2) of fuel-water separator.



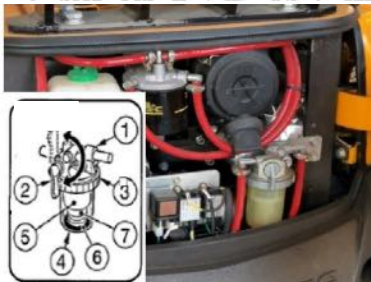

Rotate the starter key to ON and hold for approximately 60s. The automatic air bleeding valve bleeds the air from fuel system.



Note: The air content in the fuel system will cause start failure or other problems of engine. Ensure to bleed the air when the fuel tank is empty, or the fuel system contains air.

Flashing of Warning Lamps

If a warning tone is heard or a warning lamp starts to flash during operations, park the machine in a safe place and take the following remedy measures.

Warning lamp	Lamp name	Cause and solution
	Charging warning lamp	<p>The fan belt or charger is malfunctioned.</p> <p>Check the fan belt for looseness and breakage and when necessary, adjust.</p> <p>If the lamp continues to flash after maintenance, the charger is probably malfunctioned. If the help is needed, please consult with your sales or service dealer.</p>
	Engine oil pressure indicator lamp	<p>The engine lubrication system is internally malfunctioned.</p> <p>Check the engine oil level.</p> <p>If this lamp flashes when the oil level is normal or still flashes after adding of oil, please consult with your sales or service dealer.</p>
	Water temperature warning lamp	The coolant temperature is too high, and the engine is overheated.
	Fuel level warning lamp	The fuel level is low. Add fuel.

Other Symptoms

For the symptoms not listed in table below or the further existed problems after appropriate solutions, please consult with your sales or service dealer.

Symptom	Main cause	Solution
	Track tension adjustment malfunction	Adjust tracks to specified tension.
Impossible change of traveling speed	Burnout of fuse	Replace fuse.
No steering or inflexible steering	Insufficient grease for slewing bearing	Lubricate bearings.
Over-high temperature of hydraulic oil	Under-low hydraulic oil level	Add oil till the specified level is reached.
Running of starter motor but no start of engine	Insufficient fuel	Add fuel.
	Air content in fuel system	Bleed the air.
	Water content in fuel system	Drain water.
Track falloff	Loose tracks	Increase tension.
Occasional black smoke from engine	Air filter blockage	Clean air filter
White or blue smoke from engine	Excessive engine oil	Adjust till the specified level is reached.
	Low quality fuel	Replace fuel.
Irregular noise of engine (Combustion or mechanical noise)	Use of low-quality fuel	Replace fuel.
	Engine overheating	Refer to overheating section of manual
	Internal damage of exhaust pipe	Replace exhaust pipe. For replacement, please consult with your sales or service dealer.

Symptom	Main cause	Solution
Inflexible motion of left/right joystick Inflexible motion of bulldozing blade	<ul style="list-style-type: none"> ● Shortage of grease for left/right joystick ● Loose wires 	<ul style="list-style-type: none"> ● Lubricate joystick. ● Adjust or replace (Please consult with your sales or service dealer).
Operation failure of bucket working device, slewing, or traveling	<ul style="list-style-type: none"> ● Lifted (locked) safety lock handle 	<ul style="list-style-type: none"> ● Lower down (Unlock) safety lock handle.
	<ul style="list-style-type: none"> ● Burnout of fuse 	<ul style="list-style-type: none"> ● Replace fuse.
	<ul style="list-style-type: none"> ● Traveling lock adjustment malfunction 	<ul style="list-style-type: none"> ● Adjust traveling lock (Please consult with your sales or service dealer).
Insufficient digging force	<ul style="list-style-type: none"> ● Under-low hydraulic oil 	<ul style="list-style-type: none"> ● Add oil till the specified level is reached.
	<ul style="list-style-type: none"> ● Low hydraulic oil temperature 	<ul style="list-style-type: none"> ● Warm up the machine.
	<ul style="list-style-type: none"> ● Air filter blockage 	<ul style="list-style-type: none"> ● Clean air filter.
	<ul style="list-style-type: none"> ● Incorrect hydraulic oil type 	<ul style="list-style-type: none"> ● Replace hydraulic oil.
No traveling or inflexible traveling	<ul style="list-style-type: none"> ● Blockage by stone or impurity 	<ul style="list-style-type: none"> ● Remove impurities.
Leftward/rightward steering of machine	<ul style="list-style-type: none"> ● Blockage by stone or impurity 	<ul style="list-style-type: none"> ● Remove impurities.

Towing

During towing, the improper operations, the incorrect use of rope, or the improper checking can cause serious injuries or deaths.

Use ropes compatible with the towing force.

Do not use any kinked, twisted, or damaged rope.

Do not suddenly apply heavy load onto the rope.

Please wear safety gloves during the handling of rope.

Ensure that an operator is assigned each on the towing machine and the towed machine.

Do not operate the towing operation on a slope.

Keep all personnel away from the rope during towing.

Important: Do not tow the machine when the engine is not started, or the machine is not running. Otherwise, the towed machine may be damaged.

Important: Please ensure to abide by the following procedure when the machine is towed

Use the following procedure to drag a heavy object or a machine entrapped in mud.

Permissible force: 28.2KN

Affix the rope to the hook ring (1).

Hook the hook ring (1) to the traction hole (2).

Ensure that the rope maintains a 20° or smaller angle with the traveling frame.

Move the machine to tension the rope.

Drive the machine at 2km/h or lower speed to a position (Easy for repairs) within a short range from the site.

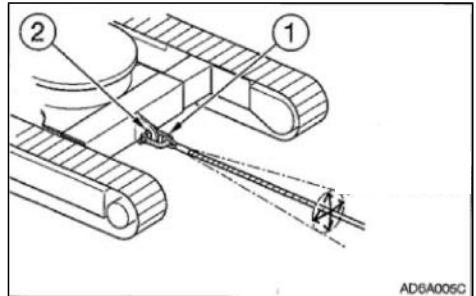

Damage of Cab or Shelter

Warning: immediately replace damaged cab or shelter. Operating with damaged cab/shelter may cause serious personal injuries or deaths.

Do not operate the machine until the replacement is completed. Do not attempt to repair damaged cab or shelter by welding. Otherwise, it may endanger the safety of cab/shelter.

Support:

For spare parts, warranties and after sales queries, please complete the form at www.aftersalescare.com.au